



# SLOVENSKI STANDARD SIST EN ISO 15750-3:2008

01-oktober-2008

---

9a VUÛjU!>Y`Yb]gcX]!' "XY.'G]ghYa ]nUd]fUb^Un]j ghUj`^Yb]a `cVfc Ya `fIGC  
%+) \$!' .&\$&L

Packaging - Steel drums - Part 3: Inserted flange-type closure systems (ISO 15750-3:2002)

Verpackung - Stahlfässer - Teil 3: Verschlussysteme mit eingesetztem Flansch (ISO 15750-3:2002)

Emballages - Futs en acier - Partie 3: Systemes de fermeture a collerette (filetée) sertie (ISO 15750-3:2002)

**Ta slovenski standard je istoveten z: EN ISO 15750-3:2008**

---

**ICS:**

55.140      Û[ åãS[ çã • \ á [ åãÛ[ \ ^      Barrels. Drums. Canisters

**SIST EN ISO 15750-3:2008**

**en,fr,de**

**iTeh STANDARD PREVIEW**  
**(standards.iteh.ai)**

[SIST EN ISO 15750-3:2008](#)

<https://standards.iteh.ai/catalog/standards/sist/8d6b6747-7746-4955-ab78-2e253b40f9c4/sist-en-iso-15750-3-2008>

EUROPEAN STANDARD

EN ISO 15750-3

NORME EUROPÉENNE

EUROPÄISCHE NORM

June 2008

ICS 55.140

English Version

## Packaging - Steel drums - Part 3: Inserted flange-type closure systems (ISO 15750-3:2002)

Emballages - Fûts en acier - Partie 3: Systèmes de fermeture à collerette (filetée) sertie (ISO 15750-3:2002)

Verpackung - Stahlfässer - Teil 3: Verschlussysteme mit eingesetztem Flansch (ISO 15750-3:2002)

This European Standard was approved by CEN on 16 May 2008.

CEN members are bound to comply with the CEN/CENELEC Internal Regulations which stipulate the conditions for giving this European Standard the status of a national standard without any alteration. Up-to-date lists and bibliographical references concerning such national standards may be obtained on application to the CEN Management Centre or to any CEN member.

This European Standard exists in three official versions (English, French, German). A version in any other language made by translation under the responsibility of a CEN member into its own language and notified to the CEN Management Centre has the same status as the official versions.

CEN members are the national standards bodies of Austria, Belgium, Bulgaria, Cyprus, Czech Republic, Denmark, Estonia, Finland, France, Germany, Greece, Hungary, Iceland, Ireland, Italy, Latvia, Lithuania, Luxembourg, Malta, Netherlands, Norway, Poland, Portugal, Romania, Slovakia, Slovenia, Spain, Sweden, Switzerland and United Kingdom.

[SIST EN ISO 15750-3:2008](https://standards.iteh.ai/catalog/standards/sist/8d6b6747-7746-4955-ab78-2e253b40f9c4/sist-en-iso-15750-3-2008)

<https://standards.iteh.ai/catalog/standards/sist/8d6b6747-7746-4955-ab78-2e253b40f9c4/sist-en-iso-15750-3-2008>



EUROPEAN COMMITTEE FOR STANDARDIZATION  
COMITÉ EUROPÉEN DE NORMALISATION  
EUROPÄISCHES KOMITEE FÜR NORMUNG

Management Centre: rue de Stassart, 36 B-1050 Brussels

**Contents**

Page

Foreword.....3

**iTeh STANDARD PREVIEW  
(standards.iteh.ai)**

SIST EN ISO 15750-3:2008

<https://standards.iteh.ai/catalog/standards/sist/8d6b6747-7746-4955-ab78-2e253b40f9c4/sist-en-iso-15750-3-2008>

## Foreword

The text of ISO 15750-3:2002 has been prepared by Technical Committee ISO/TC 122 “Packaging” of the International Organization for Standardization (ISO) and has been taken over as EN ISO 15750-3:2008 by Technical Committee CEN/TC 261 “Packaging” the secretariat of which is held by AFNOR.

This European Standard shall be given the status of a national standard, either by publication of an identical text or by endorsement, at the latest by December 2008, and conflicting national standards shall be withdrawn at the latest by December 2008.

Attention is drawn to the possibility that some of the elements of this document may be the subject of patent rights. CEN [and/or CENELEC] shall not be held responsible for identifying any or all such patent rights.

According to the CEN/CENELEC Internal Regulations, the national standards organizations of the following countries are bound to implement this European Standard: Austria, Belgium, Bulgaria, Cyprus, Czech Republic, Denmark, Estonia, Finland, France, Germany, Greece, Hungary, Iceland, Ireland, Italy, Latvia, Lithuania, Luxembourg, Malta, Netherlands, Norway, Poland, Portugal, Romania, Slovakia, Slovenia, Spain, Sweden, Switzerland and the United Kingdom.

## iTeh STANDARD PREVIEW Endorsement notice (standards.iteh.ai)

The text of ISO 15750-3:2002 has been approved by CEN as a EN ISO 15750-3:2008 without any modification.

[SIST EN ISO 15750-3:2008](https://standards.iteh.ai/catalog/standards/sist/8d6b6747-7746-4955-ab78-2e253b40f9c4/sist-en-iso-15750-3-2008)

<https://standards.iteh.ai/catalog/standards/sist/8d6b6747-7746-4955-ab78-2e253b40f9c4/sist-en-iso-15750-3-2008>

**iTeh STANDARD PREVIEW**  
**(standards.iteh.ai)**

SIST EN ISO 15750-3:2008

<https://standards.iteh.ai/catalog/standards/sist/8d6b6747-7746-4955-ab78-2e253b40f9c4/sist-en-iso-15750-3-2008>

INTERNATIONAL  
STANDARD

ISO  
15750-3

First edition  
2002-04-15

---

---

**Packaging — Steel drums —**  
**Part 3:**  
**Inserted flange-type closure systems**

*Emballages — Fûts en acier —*

*Partie 3: Systèmes de fermeture à collerette (filetée) sertie*

iTeh STANDARD PREVIEW  
(standards.iteh.ai)

[SIST EN ISO 15750-3:2008](https://standards.iteh.ai/catalog/standards/sist/8d6b6747-7746-4955-ab78-2e253b40f9c4/sist-en-iso-15750-3-2008)

[https://standards.iteh.ai/catalog/standards/sist/8d6b6747-7746-4955-  
ab78-2e253b40f9c4/sist-en-iso-15750-3-2008](https://standards.iteh.ai/catalog/standards/sist/8d6b6747-7746-4955-ab78-2e253b40f9c4/sist-en-iso-15750-3-2008)



Reference number  
ISO 15750-3:2002(E)

© ISO 2002

**ISO 15750-3:2002(E)****PDF disclaimer**

This PDF file may contain embedded typefaces. In accordance with Adobe's licensing policy, this file may be printed or viewed but shall not be edited unless the typefaces which are embedded are licensed to and installed on the computer performing the editing. In downloading this file, parties accept therein the responsibility of not infringing Adobe's licensing policy. The ISO Central Secretariat accepts no liability in this area.

Adobe is a trademark of Adobe Systems Incorporated.

Details of the software products used to create this PDF file can be found in the General Info relative to the file; the PDF-creation parameters were optimized for printing. Every care has been taken to ensure that the file is suitable for use by ISO member bodies. In the unlikely event that a problem relating to it is found, please inform the Central Secretariat at the address given below.

## iTeh STANDARD PREVIEW (standards.iteh.ai)

[SIST EN ISO 15750-3:2008](https://standards.iteh.ai/catalog/standards/sist/8d6b6747-7746-4955-ab78-2e253b40f9c4/sist-en-iso-15750-3-2008)

<https://standards.iteh.ai/catalog/standards/sist/8d6b6747-7746-4955-ab78-2e253b40f9c4/sist-en-iso-15750-3-2008>

© ISO 2002

All rights reserved. Unless otherwise specified, no part of this publication may be reproduced or utilized in any form or by any means, electronic or mechanical, including photocopying and microfilm, without permission in writing from either ISO at the address below or ISO's member body in the country of the requester.

ISO copyright office  
Case postale 56 • CH-1211 Geneva 20  
Tel. + 41 22 749 01 11  
Fax + 41 22 749 09 47  
E-mail [copyright@iso.ch](mailto:copyright@iso.ch)  
Web [www.iso.ch](http://www.iso.ch)

Printed in Switzerland



## Contents

	Page
Foreword.....	iv
<b>1 Scope .....</b>	<b>1</b>
<b>2 Normative references .....</b>	<b>1</b>
<b>3 Terms and definitions .....</b>	<b>1</b>
<b>4 Dimensions, materials and finish .....</b>	<b>2</b>
<b>5 Design and construction.....</b>	<b>2</b>
<b>5.1 Flanges .....</b>	<b>2</b>
<b>5.2 Plugs .....</b>	<b>2</b>
<b>5.3 Capseals and overseals .....</b>	<b>3</b>
<b>5.4 Label rings and protection rings.....</b>	<b>3</b>
<b>Annex A (normative) Octagonal base closure system (type A closure) .....</b>	<b>4</b>
<b>Annex B (normative) Serrated base closure system (type B closure) .....</b>	<b>17</b>
<b>Annex C (normative) Octagonal(G 2)/hexagonal (G 3/4) base closure system (type C closure).....</b>	<b>27</b>
<b>Annex D (informative) Plug wrench adaptors .....</b>	<b>37</b>
<b>Annex E (informative) Closing torques.....</b>	<b>41</b>
<b>Bibliography.....</b>	<b>43</b>

SIST EN ISO 15750-3:2008

<https://standards.iteh.ai/catalog/standards/sist/8d6b6747-7746-4955-ab78-2e253b40f9c4/sist-en-iso-15750-3-2008>

## ISO 15750-3:2002(E)

## Foreword

ISO (the International Organization for Standardization) is a worldwide federation of national standards bodies (ISO member bodies). The work of preparing International Standards is normally carried out through ISO technical committees. Each member body interested in a subject for which a technical committee has been established has the right to be represented on that committee. International organizations, governmental and non-governmental, in liaison with ISO, also take part in the work. ISO collaborates closely with the International Electrotechnical Commission (IEC) on all matters of electrotechnical standardization.

International Standards are drafted in accordance with the rules given in the ISO/IEC Directives, Part 3.

The main task of technical committees is to prepare International Standards. Draft International Standards adopted by the technical committees are circulated to the member bodies for voting. Publication as an International Standard requires approval by at least 75 % of the member bodies casting a vote.

Attention is drawn to the possibility that some of the elements of this part of ISO 15750 may be the subject of patent rights. ISO shall not be held responsible for identifying any or all such patent rights.

ISO 15750-3 was prepared by Technical Committee ISO/TC 122, *Packaging*.

ISO 15750 consists of the following parts, under the general title *Packaging — Steel drums*:

- *Part 1: Removable head (open head) drums with a minimum total capacity of 208 l, 210 l and 216,5 l*
- *Part 2: Non-removable head (tight head) drums with a minimum total capacity of 212 l, 216,5 l and 230 l*
- *Part 3: Inserted flange-type closure systems*

Annexes A to C form a normative part of this part of ISO 15750. Annexes D and E are for information only.

# Packaging — Steel drums —

## Part 3: Inserted flange-type closure systems

### 1 Scope

This part of ISO 15750 specifies the characteristics, dimensions and finish of the inserted flange-type closure systems used for steel drums.

### 2 Normative references

The following normative documents contain provisions which, through reference in this text, constitute provisions of this part of ISO 15750. For dated references, subsequent amendments to, or revisions of, any of these publications do not apply. However, parties to agreements based on this part of ISO 15750 are encouraged to investigate the possibility of applying the most recent editions of the normative documents indicated below. For undated references, the latest edition of the normative document referred to applies. Members of ISO and IEC maintain registers of currently valid International Standards.

ISO 228-1, *Pipe threads where pressure-tight joints are not made on the threads — Part 1: Dimensions, tolerances and designation*

<https://standards.iteh.ai/catalog/standards/sist/8d6b6747-7746-4955-ab78-2e253b40f9c4/sist-en-iso-15750-3-2008>

ISO 228-2, *Pipe threads where pressure-tight joints are not made on the threads — Part 2: Verification by means of limit gauges*

ISO 301, *Zinc alloy ingots intended for casting*

ISO 3573, *Hot-rolled carbon steel sheet of commercial and drawing qualities*

ISO 3574, *Cold-reduced carbon steel sheet of commercial and drawing qualities*

ISO 5002, *Hot-rolled and cold-reduced electrolytic zinc-coated carbon steel sheet of commercial and drawing qualities*

ISO 11949, *Cold reduced electrolytic tinplate*

ISO 11950, *Cold reduced electrolytic chromium/chromium oxide-coated steel*

### 3 Terms and definitions

For the purposes of this part of ISO 15750, the following terms and definitions apply.

#### 3.1

##### **inserted flange-type closure**

mechanical fixed steel insert with threads, closable with plugs made of steel, other metals or synthetic materials such as plastics, ensuring a leaktight closing in drums

**ISO 15750-3:2002(E)****3.2****elastomer**

macromolecular material which returns rapidly to its initial dimensions and shape after substantial deformation by a weak stress and release of the stress

[ISO 472:1999]

**3.3****thermoplastics**

plastics that are capable of being repeatedly softened by heating and hardened by cooling through a temperature range characteristic of the plastics and, in the softened state, of being repeatedly shaped by flow into articles by moulding, extrusion or forming

**4 Dimensions, materials and finish**

**4.1** The nominal pitch diameter and the pitch of the thread of the closures G 2 and G 3/4 shall conform to ISO 228-1.

These closures shall fit GO gauges conforming to ISO 228-2.

**4.2** The dimensions and materials of the closure systems shall be in accordance with the relevant annexes for the closure type, i.e.:

- annex A: octagonal base closure system (type A closure);
- annex B: serrated base closure system (type B closure);
- annex C: octagonal (G 2)/hexagonal (G 3/4) base closure system (type C closure).

**4.3** The finish of the flanges, steel plugs, label rings and protection rings shall be electrolytically zinc plated.

If for reasons of compatibility another finish of the closure system is required, the nature of the internal and external finish should be agreed upon between the purchaser and supplier.

**5 Design and construction****5.1 Flanges**

The flanges shall be the mechanical inserted type and shall make a leaktight fit when inserted.

**5.2 Plugs**

The plugs shall be designed so that they can be inserted or removed by means of a simple tool.

The plugs shall have a wrenching insert projection welded to the bottom of the sump of the plug or have a wrenching device formed as part of the plug.

The dimensions of the wrenching insert shall be such that the plugs can be operated by a universal tool for steel and plastics plugs. Examples are shown in annex D.

NOTE For recommended closing torques, see annex E.

### 5.3 Capseals and overseals

Capseals or overseals, when fitted, shall be the manual or pneumatic crimping type and shall have provisions for customs sealing and evidence of tampering.

Capseals/overseals shall be so designed that they can be removed by means of a simple tool.

### 5.4 Label rings and protection rings

Label rings and/or protection rings shall be designed so that, when fitted, they can be mechanically inserted simultaneously with the flanges. Label rings shall have provisions for customs sealing.

NOTE Label rings and/or protection rings can provide adequate reinforcement for the flange insertion and can protect the drum stock neck against corrosion.

**iTeh STANDARD PREVIEW**  
**(standards.iteh.ai)**

[SIST EN ISO 15750-3:2008](https://standards.iteh.ai/catalog/standards/sist/8d6b6747-7746-4955-ab78-2e253b40f9c4/sist-en-iso-15750-3-2008)

<https://standards.iteh.ai/catalog/standards/sist/8d6b6747-7746-4955-ab78-2e253b40f9c4/sist-en-iso-15750-3-2008>

## Annex A (normative)

### Octagonal base closure system (type A closure)

#### A.1 Nomenclature for closure system

Closure components of the closure system may deviate from those shown in Figures A.1 and A.2. However the specified dimensions shall be followed.

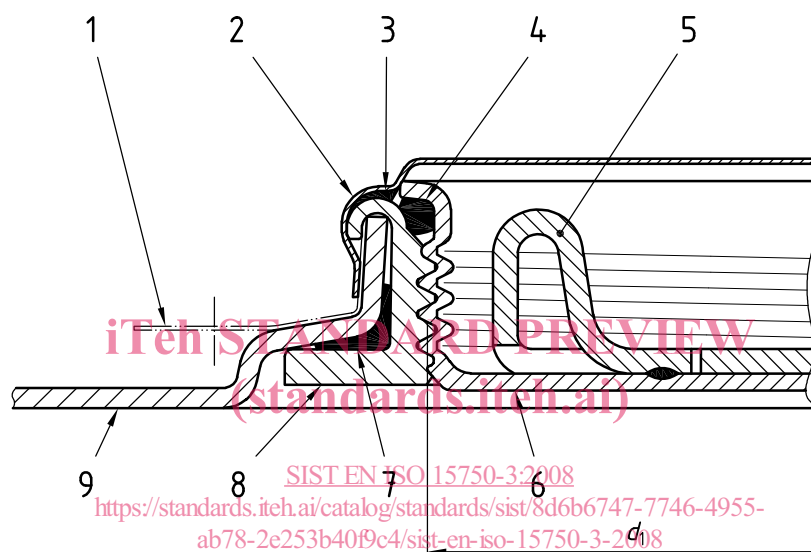

$d_1$  is the nominal pitch diameter.

#### Key

- |   |                                     |   |                         |
|---|-------------------------------------|---|-------------------------|
| 1 | Optional label ring/protection ring | 6 | Example with steel plug |
| 2 | Capseal                             | 7 | Elastomer flange washer |
| 3 | Gasket                              | 8 | Flange                  |
| 4 | Plug washer                         | 9 | Drum stock              |
| 5 | Wrenching insert                    |   |                         |

Figure A.1 — Assembly in medium- and heavy-gauge stock

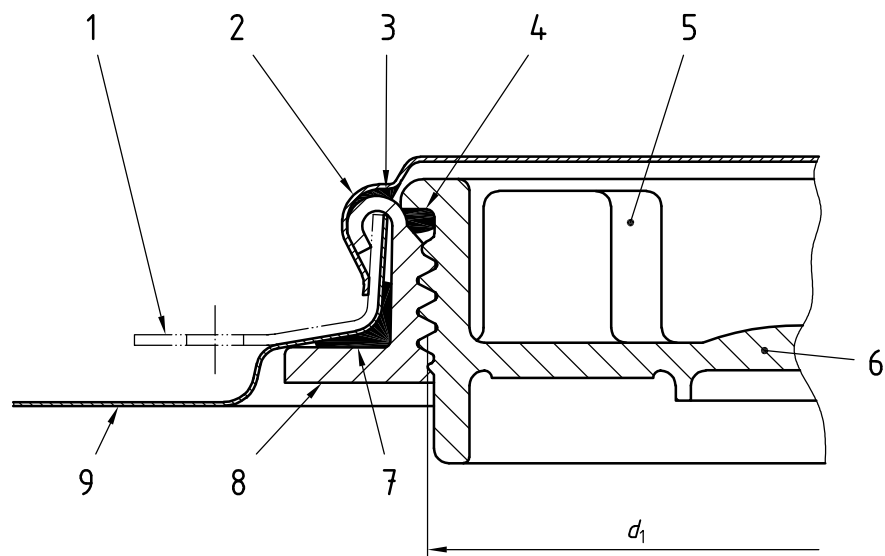

$d_1$  is the nominal pitch diameter.

#### Key

- |   |                            |   |                           |
|---|----------------------------|---|---------------------------|
| 1 | Label ring/protection ring | 6 | Example with plastic plug |
| 2 | Capseal                    | 7 | Elastomer flange washer   |
| 3 | Gasket                     | 8 | Flange                    |
| 4 | Plug washer                | 9 | Drum stock                |
| 5 | Wrenching insert           |   |                           |

iTeh STANDARD PREVIEW  
(standards.iteh.ai)

**Figure A.2 — Assembly in light-gauge drum stock**

<https://standards.iteh.ai/catalog/standards/sist/8d6b6747-7746-4955-ab78-2e253b40f9c4/sist-en-iso-15750-3-2008>