



SLOVENSKI STANDARD

SIST ISO 16589-4:2002

01-julij-2002

Fluidna tehnika - Ustnične gredne tesnilke s termoplastičnimi tesnilnimi elementi - 4. del: Postopki preskušanja

Rotary shaft lip-type seals incorporating thermoplastic sealing elements -- Part 4:
Performance test procedures

iTeh STANDARD PREVIEW

Bagues d'étanchéité à lèvres pour arbres tournants incorporant des éléments
d'étanchéité thermoplastiques -- Partie 4: Méthodes d'essai de performance

[SIST ISO 16589-4:2002](https://standards.itih.ai/catalog/standards/sist/da8dc8eb-1e47-4b99-822d-991c1c1df33/sist-iso-16589-4-2002)

Ta slovenski standard je istoveten z: [ISO 16589-4:2001](https://standards.itih.ai/catalog/standards/sist/da8dc8eb-1e47-4b99-822d-991c1c1df33/sist-iso-16589-4-2002)

ICS:

23.100.60	Filtri, tesnila in onesnaževanje tekočin	Filters, seals and contamination of fluids
-----------	---------------------------------------------	-----------------------------------------------

SIST ISO 16589-4:2002

en

iTeh STANDARD PREVIEW
(standards.iteh.ai)

SIST ISO 16589-4:2002

<https://standards.iteh.ai/catalog/standards/sist/da8dc8eb-1e47-4b99-822d-991c1c1dff33/sist-iso-16589-4-2002>

INTERNATIONAL STANDARD

ISO
16589-4

First edition
2001-12-15

Rotary shaft lip-type seals incorporating thermoplastic sealing elements —

Part 4: Performance test procedures

*Bagues d'étanchéité à lèvres pour arbres tournants incorporant des
éléments d'étanchéité thermoplastiques —*

Partie 4: Méthodes d'essai de performance

[SIST ISO 16589-4:2002](https://standards.iteh.ai/catalog/standards/sist/da8dc8eb-1e47-4b99-822d-991c1c1dff33/sist-iso-16589-4-2002)

<https://standards.iteh.ai/catalog/standards/sist/da8dc8eb-1e47-4b99-822d-991c1c1dff33/sist-iso-16589-4-2002>



Reference number
ISO 16589-4:2001(E)

© ISO 2001

ISO 16589-4:2001(E)**PDF disclaimer**

This PDF file may contain embedded typefaces. In accordance with Adobe's licensing policy, this file may be printed or viewed but shall not be edited unless the typefaces which are embedded are licensed to and installed on the computer performing the editing. In downloading this file, parties accept therein the responsibility of not infringing Adobe's licensing policy. The ISO Central Secretariat accepts no liability in this area.

Adobe is a trademark of Adobe Systems Incorporated.

Details of the software products used to create this PDF file can be found in the General Info relative to the file; the PDF-creation parameters were optimized for printing. Every care has been taken to ensure that the file is suitable for use by ISO member bodies. In the unlikely event that a problem relating to it is found, please inform the Central Secretariat at the address given below.

iTeh STANDARD PREVIEW (standards.iteh.ai)

SIST ISO 16589-4:2002

<https://standards.iteh.ai/catalog/standards/sist/da8dc8eb-1e47-4b99-822d-991c1c1dff33/sist-iso-16589-4-2002>

© ISO 2001

All rights reserved. Unless otherwise specified, no part of this publication may be reproduced or utilized in any form or by any means, electronic or mechanical, including photocopying and microfilm, without permission in writing from either ISO at the address below or ISO's member body in the country of the requester.

ISO copyright office
Case postale 56 • CH-1211 Geneva 20
Tel. + 41 22 749 01 11
Fax + 41 22 749 09 47
E-mail copyright@iso.ch
Web www.iso.ch

Printed in Switzerland

Contents

	Page
Foreword.....	iv
Introduction.....	v
1 Scope	1
2 Normative references	1
3 Terms and definitions	1
4 Pre-test procedure.....	1
5 Dynamic test	2
5.1 Test apparatus	2
5.2 Installation	3
5.3 Test conditions	4
5.4 Test procedure.....	4
5.5 Post-test measurements	4
5.6 Recording	4
5.7 Acceptance criteria.....	4
6 Dynamic low temperature test	4
6.1 General.....	4
6.2 Test apparatus	4
6.3 Installation.....	5
6.4 Test procedure.....	5
6.5 Post-test measurements	6
6.6 Recording	6
6.7 Acceptance criteria.....	6
7 Material testing of the rotary shaft seal components	6
7.1 General.....	6
7.2 Metallic components (cases).....	6
7.3 Non-metallic components.....	6
8 Identification statement (Reference to this part of ISO 16589).....	6
Annex A (informative) An example of seal test report for the dynamic test	7
Annex B (informative) An example of a seal test report for the dynamic low temperature test.....	9
Annex C (informative) An example of a material test report (thermoplastic)	11
Annex D (informative) An example of a material test report (elastomer)	12
Bibliography	14

ISO 16589-4:2001(E)

Foreword

ISO (the International Organization for Standardization) is a worldwide federation of national standards bodies (ISO member bodies). The work of preparing International Standards is normally carried out through ISO technical committees. Each member body interested in a subject for which a technical committee has been established has the right to be represented on that committee. International organizations, governmental and non-governmental, in liaison with ISO, also take part in the work. ISO collaborates closely with the International Electrotechnical Commission (IEC) on all matters of electrotechnical standardization.

International Standards are drafted in accordance with the rules given in the ISO/IEC Directives, Part 3.

The main task of technical committees is to prepare International Standards. Draft International Standards adopted by the technical committees are circulated to the member bodies for voting. Publication as an International Standard requires approval by at least 75 % of the member bodies casting a vote.

Attention is drawn to the possibility that some of the elements of this part of ISO 16589 may be the subject of patent rights. ISO shall not be held responsible for identifying any or all such patent rights.

ISO 16589-4 was prepared by Technical Committee ISO/TC 131, *Fluid power systems*, Subcommittee SC 7, *Sealing devices*.

ISO 16589 consists of the following parts, under the general title *Rotary shaft lip-type seals incorporating thermoplastic sealing elements*:

— Part 1: *Nominal dimensions and tolerances*

— Part 2: *Vocabulary*

— Part 3: *Storage, handling and installation*

— Part 4: *Performance test procedures*

— Part 5: *Identification of visual imperfections*

Annexes A, B, C and D of this part of ISO 16589 are for information only.

ITeH STANDARD PREVIEW
(standards.iteh.ai)

[SIST ISO 16589-4:2002](https://standards.iteh.ai/catalog/standards/sist/da8dc8eb-1e47-4b99-822d-991c1c1dff33/sist-iso-16589-4-2002)

[https://standards.iteh.ai/catalog/standards/sist/da8dc8eb-1e47-4b99-822d-](https://standards.iteh.ai/catalog/standards/sist/da8dc8eb-1e47-4b99-822d-991c1c1dff33/sist-iso-16589-4-2002)

[991c1c1dff33/sist-iso-16589-4-2002](https://standards.iteh.ai/catalog/standards/sist/da8dc8eb-1e47-4b99-822d-991c1c1dff33/sist-iso-16589-4-2002)

Introduction

Rotary shaft lip-type seals are used to retain fluid in equipment where the differential pressure is relatively low. Typically, the shaft rotates and the housing is stationary although in some applications the shaft is stationary and the housing rotates.

Dynamic sealing is normally the result of a designed interference fit between the shaft and a flexible element incorporated in the seal.

Similarly, a designed interference fit between the outside diameter of the seal and the diameter of the housing bore retains the seal and prevents static leakage.

Careful storage, handling and proper installation of all seals are necessary to avoid hazards, both prior to and during installation, which would adversely affect service life.

iTeh STANDARD PREVIEW (standards.iteh.ai)

[SIST ISO 16589-4:2002](https://standards.iteh.ai/catalog/standards/sist/da8dc8eb-1e47-4b99-822d-991c1c1df33/sist-iso-16589-4-2002)

<https://standards.iteh.ai/catalog/standards/sist/da8dc8eb-1e47-4b99-822d-991c1c1df33/sist-iso-16589-4-2002>

iTeh STANDARD PREVIEW
(standards.iteh.ai)

SIST ISO 16589-4:2002

<https://standards.iteh.ai/catalog/standards/sist/da8dc8eb-1e47-4b99-822d-991c1c1dff33/sist-iso-16589-4-2002>

Rotary shaft lip-type seals incorporating thermoplastic sealing elements —

Part 4: Performance test procedures

WARNING — Persons using this part of ISO 16589 should be familiar with normal laboratory practice. Whilst it does not purport to address all the safety problems, if any, associated with its application, attention is drawn to the need to employ sensible precautions while handling hot and cold fluids and equipment. It is the responsibility of the user to establish appropriate safety and health practices and to ensure compliance with any national regulatory conditions.

1 Scope

ISO 16589 describes seals utilizing sealing elements manufactured from suitably formulated compounds, based on thermoplastic materials, such as polytetrafluoroethylene (PTFE).

NOTE ISO 16589 is complementary to ISO 6194 which covers elastomeric seals.

This part of the standard specifies general performance tests which can be used for seal qualification purposes. Materials quality control, dynamic testing and supplementary low temperature testing requirements are covered.

2 Normative references

The following normative documents contain provisions which, through reference in this text, constitute provisions of this part of ISO 16589. For dated references, subsequent amendments to, or revisions of, any of these publications do not apply. However, parties to agreements based on this part of ISO 16589 are encouraged to investigate the possibility of applying the most recent editions of the normative documents indicated below. For undated references, the latest edition of the normative document referred to applies. Members of ISO and IEC maintain registers of currently valid International Standards.

ISO 5598:1985, *Fluid power systems and components — Vocabulary*

ISO 16589-1:2001, *Rotary shaft lip-type seals incorporating thermoplastic sealing elements — Part 1: Nominal dimensions and tolerances*

ISO 16589-2:2001, *Rotary shaft lip-type seals incorporating thermoplastic sealing elements — Part 2: Vocabulary*

3 Terms and definitions

For the purposes of this part of ISO 16589, the terms and definitions given in ISO 5598 and ISO 16589-2 apply.

4 Pre-test procedure

4.1 Inspect all seals submitted for testing for conformity to a relevant drawing or detailed specification declared by the seal manufacturer

4.2 Ensure that the seal manufacturer has stated the material batch numbers from which the seals have been manufactured. For seals with an elastomeric component, ensure that the seal manufacturer has stated the material batch number from which the elastomeric component of the seal has been made.

ISO 16589-4:2001(E)

4.3 To facilitate accurate analysis of the test results, determine the following data concerning the physical characteristics of the seal and test apparatus before testing:

- a) lip diameter immediately prior to assembly onto the shaft;
- b) lip thickness when measured as assembled on the test shaft;
- c) outer case mean diameter and out-of-roundness;
- d) shaft diameter, material, hardness and surface roughness;
- e) housing diameter, material and surface roughness;
- f) wiper lip diameter, when applicable.

NOTE 1 For parts a), b) and f), measuring instruments with sharp edges should not be used.

NOTE 2 Measurement of the radial lip load before the test is not recommended.

4.4 Ensure that the specified shaft eccentricity and housing off-set of the test apparatus have been incorporated.

5 Dynamic test**5.1 Test apparatus**

The test apparatus shall be similar to the typical example shown in Figure 1 and shall consist of a suitable housing for retaining the test fluid and for positioning the test seals, as well as a rotating member having a spindle mounted horizontally on suitable bearings. The design of the housing for the seal shall be in accordance with the dimensions specified in ISO 16589-1. The housing and the rotating member shall be capable of reproducing the eccentricity and off-set referred to in 4.4.

<https://standards.iteh.ai/catalog/standards/sist/da8dc8eb-1e47-4b99-822d-1c1a1c1a1c1a/iso-16589-4-2002>

The test apparatus shall also conform to the following additional requirements:

- a) the shaft shall be capable of cycling and/or maintaining the shaft speeds to within $\pm 5\%$;
- b) the shaft shall be capable of maintaining the specified test eccentricity under dynamic conditions to within $\pm 0,03$ mm throughout each test;
- c) the test head shall be designed and constructed so as to maintain the housing bore alignment relative to the test shaft axis within 0,03 mm throughout the operating temperature range;
- d) the design of the test head support shall ensure minimum deformation and vibration;
- e) the test head and heat transfer system shall be capable of maintaining the temperature of the test fluid within ± 5 °C and shall be vented to atmosphere;
- f) heat shall be applied in a manner that does not subject the test fluid to high localized temperatures which could cause fluid decomposition;
- g) the test shaft shall have a surface which is free of helical machine marks and shall comply with the requirements specified in ISO 16589-1:2001, clause 7;
- h) the test housing bore shall comply with the requirements specified in ISO 16589-1:2001, clause 8;
- i) the material properties, including hardness, surface finish and dimensions of the test shaft and test housing bore, shall conform as closely as possible to the shaft and housing bore, to be used in service;
- j) a minimum quantity of 0,75 l of test fluid shall be used;

- k) the level of the test fluid in the test head shall be $0,3d$ to $0,5d$ above the lowest point of the shaft diameter d ;
- l) where the seal housings have inboard bearings, the test housing shall be suitably relieved at the bearing supports to prevent excessive fluid pressure between the bearing and seals;
- m) means shall be provided for collecting and measuring the mass of any fluid leakage from the seals during the test.

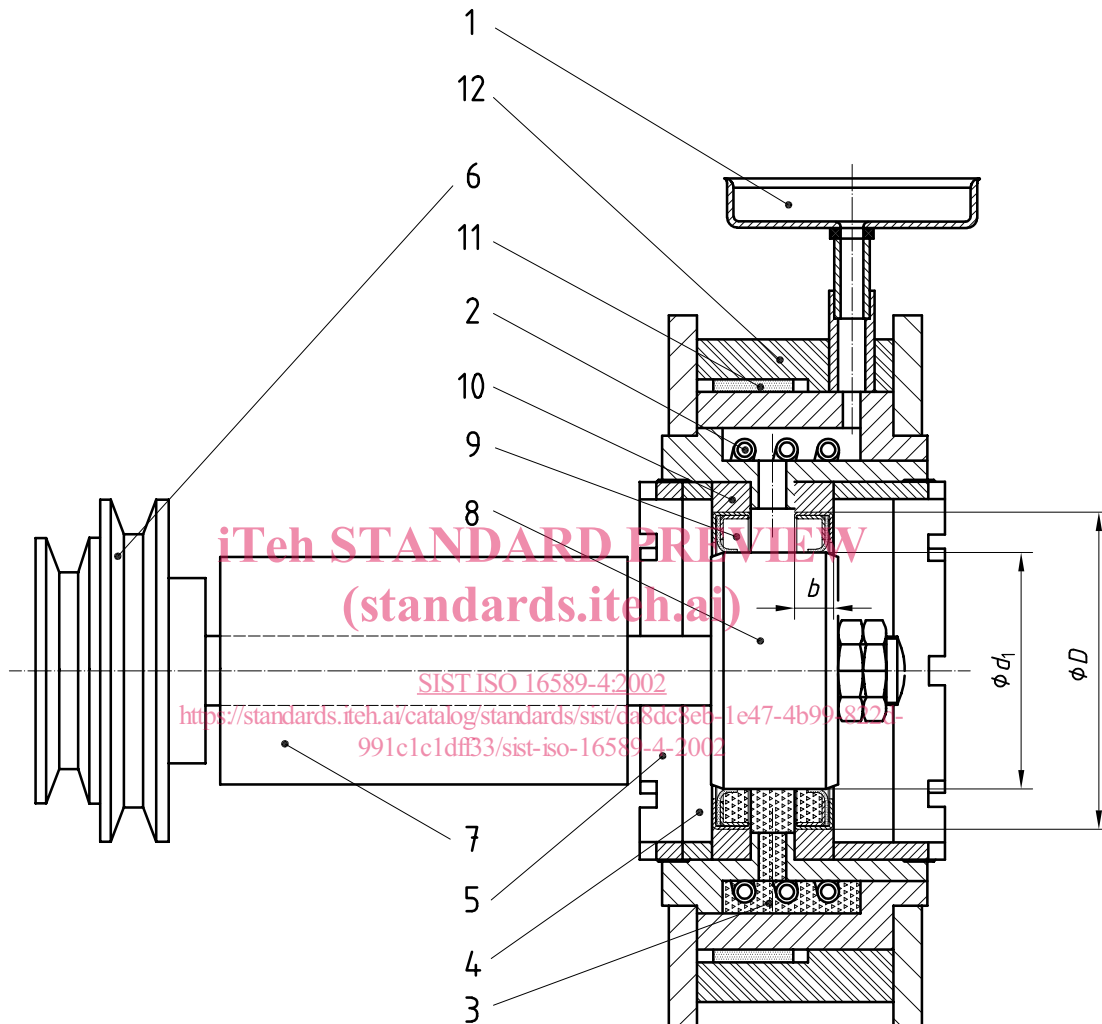

See ISO 16589-1 for symbols.

Key

1	Filler tray	5	Locking ring	9	Test seal
2	Cooling coil	6	Drive from prime mover	10	Seal housing
3	Test fluid	7	Test head support	11	Heater band
4	Spacer ring	8	Test shaft	12	Insulation

Figure 1 — Typical example of dynamic test apparatus

5.2 Installation

5.2.1 Thoroughly clean the test head of contaminants and extraneous matter.

5.2.2 Install the seal into the test head so that the cumulative eccentricities of the seal and the test head are known.