



Designation: E 190 – 92 (Reapproved 2003)

Standard Test Method for Guided Bend Test for Ductility of Welds¹

This standard is issued under the fixed designation E 190; the number immediately following the designation indicates the year of original adoption or, in the case of revision, the year of last revision. A number in parentheses indicates the year of last reapproval. A superscript epsilon (ϵ) indicates an editorial change since the last revision or reapproval.

This standard has been approved for use by agencies of the Department of Defense.

1. Scope

1.1 This test method covers a guided bend test for the determination of soundness and ductility of welds in ferrous and nonferrous products. Defects, not shown by X rays, may appear in the surface of a specimen when it is subjected to progressive localized overstressing. This guided bend test has been developed primarily for plates and is not intended to be substituted for other methods of bend testing.

1.2 The values stated in inch-pound units are to be regarded as the standard. The SI equivalents are in parentheses and may be approximate.

NOTE 1—For additional information see Terminology E 6, and American Welding Society Standard D 1.1.

1.3 *This standard does not purport to address all of the safety concerns, if any, associated with its use. It is the responsibility of the user of this standard to establish appropriate safety and health practices and determine the applicability of regulatory limitations prior to use.*

2. Referenced Documents

2.1 *ASTM Standards:*

E 6 Terminology Relating to Methods of Mechanical Testing²

2.2 *AWS Standard:*

D1.1 Structural Welding Code, Steel³

3. Summary of Test Method

3.1 The specimen is bent in a U-shaped die by means of a centrally applied force to the weldment in a flat specimen supported at two positions equidistant from the line of force application. The specimen is forced into the die by a plunger

having the shape necessary to produce the desired contour. The convex surface of the bent specimen is examined for cracks or other open defects.

4. Significance and Use

4.1 The guided bend test as described in this test method is used to evaluate the quality of welds as a function of ductility as evidenced by their ability to resist cracking during bending.

5. Apparatus

5.1 The guided bend test jig is shown in Fig. 1 (see Explanatory Notes at end of this test method).

6. Sampling

6.1 Sampling is performed in accordance with the requirements of relevant specifications and codes.

7. Test Specimens

7.1 The types of specimens generally used for guided bend testing are rectangular ones machined from plates and pipes. The face surface of the flat specimen contains the greater width of the weld material, while the opposite side is called the root surface.

7.1.1 *Transverse Side Bend*—The weld is transverse to the longitudinal axis of the specimen which is bent so that either one of the side surfaces becomes the convex surface of the bent specimen (Fig. 2 and Fig. 3).

7.1.2 *Transverse Face Bend*—The weld is transverse to the longitudinal axis of the specimen which is bent so that the weld face surface becomes the convex surface of the bent specimen (Fig. 4).

7.1.3 *Transverse Root Bend*—The weld is transverse to the longitudinal axis of the specimen which is bent so that the weld-root surface becomes the convex surface of the bent specimen (Fig. 4).

7.1.4 *Longitudinal Face Bend*—The weld is parallel to the longitudinal axis of the specimen which is bent so that the weld-face surface becomes the convex surface of the bent specimen (Fig. 5).

¹ This test method is under the jurisdiction of ASTM Committee E28 on Mechanical Testing and is the direct responsibility of Subcommittee E28.02 on Ductility and Flexure Testing.

Current edition approved Aug. 10, 2003. Published September 2003. Originally approved in 1961. Last previous edition approved in 1997 as E 190 – 92 (1997).

² *Annual Book of ASTM Standards*, Vol 03.01.

³ Available from The American Welding Society (AWS), 550 NW LeJeune Rd., Miami, FL 33126.

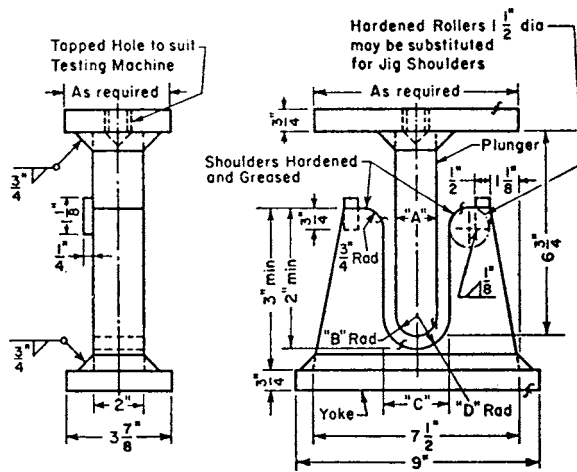

Thickness of Specimen in. (mm)	A, in. (mm)	B, in. (mm)	C, in. (mm)	D, in. (mm)
3/8 (9.5)	1 1/2 (38)	3/4 (19)	2 3/8 (60)	1 3/16 (30)
1/8 (3.2)	2 1/8 (54)	1 1/16 (27)	2 3/8 (60)	1 3/16 (30)
t	4t	2t	6t + 1/8 (+ 3.2)	3t + 1/16 (+ 1.6)

FIG. 1 Guided Bend Test Jig

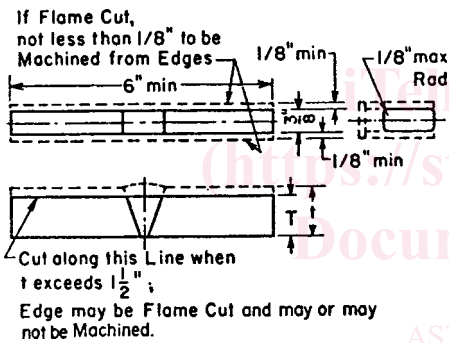

t, in. (mm)	T, in.
3/8 to 1 1/2 (9.5 to 38)	t
> 1 1/2 (38)	See Note

NOTE—For plates over 1 1/2 in. (38 mm) thick, cut specimen into approximately equal strips between 3/4 and 1 1/2 in. (19 and 38 mm) wide and test each strip.

FIG. 2 Side-Bend Specimen for Ferrous Materials

8. Procedure

8.1 Bend the guided-bend specimens in a test jig that is substantially in accordance with Fig. 1. Place transverse specimens on the die member of the jig with the weld at midspan. Place face-bend specimens with the face of the weld directed toward the gap; place root-bend specimens with the root of the weld directed toward the gap; and place side-bend specimens with the side showing the greater defects toward the gap. If no significant defects are evident, either side may be chosen.

7.1.5 Longitudinal Root Bend—The weld is parallel to the longitudinal axis of the specimen which is bent so that the weld root surface becomes the convex surface of the bent specimen (Fig. 5).

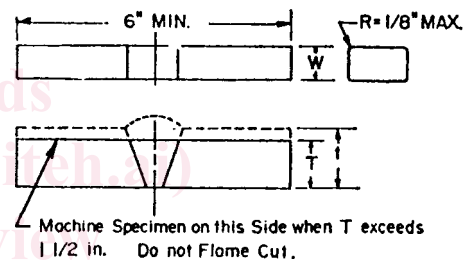

t, in. (mm)	T, in.
3/8 to 1 1/2 (9.5 to 38)	t
> 1 1/2	See Note

NOTE—For plates over 1 1/2 in. (38 mm) thick, cut specimen into approximately equal strips between 3/4 and 1 1/2 in. (19 to 38 mm) wide and test each strip.

FIG. 3 Side-Bend Specimen for Nonferrous Materials

8.2 Any convenient means may be used for moving the plunger with relation to the die; but it must be steady and without any significant lateral motion. Apply the force until the specimen conforms to a U-shape, and until a 1/8-in. (3.2 mm) diameter wire cannot be inserted between the specimen and any point on the curvature of the plunger member of the jig, unless the specimen fails earlier.

9. Interpretation of Results

9.1 Examine the convex surface of the bent specimen for cracks or other open defects.

9.1.1 When the test is conducted as an acceptance criterion, the allowable crack size shall be specified by the code or specification requiring the test.

9.1.2 When the test is conducted for informational purposes, report the size and location of all cracks visible to the unaided eye.