**Industrial valves — Measurement, test
and qualification procedures for fugitive
emissions —**

Part 1:

**Classification system and qualification
procedures for type testing of valves**

iTeh STANDARD PREVIEW
(standards.iteh.ai)

*Robinetterie industrielle — Mesurage, essais et procédures de
qualification pour émissions fugitives —*

*Partie 1. Système de classification et procédures de qualification pour
essais de type des appareils de robinetterie*



PDF disclaimer

This PDF file may contain embedded typefaces. In accordance with Adobe's licensing policy, this file may be printed or viewed but shall not be edited unless the typefaces which are embedded are licensed to and installed on the computer performing the editing. In downloading this file, parties accept therein the responsibility of not infringing Adobe's licensing policy. The ISO Central Secretariat accepts no liability in this area.

Adobe is a trademark of Adobe Systems Incorporated.

Details of the software products used to create this PDF file can be found in the General Info relative to the file; the PDF-creation parameters were optimized for printing. Every care has been taken to ensure that the file is suitable for use by ISO member bodies. In the unlikely event that a problem relating to it is found, please inform the Central Secretariat at the address given below.

iTeh STANDARD PREVIEW
(standards.iteh.ai)

[ISO 15848-1:2006](https://standards.iteh.ai/catalog/standards/sist/b84e3735-6494-43e7-9dc2-394dc0e778ba/iso-15848-1-2006)

<https://standards.iteh.ai/catalog/standards/sist/b84e3735-6494-43e7-9dc2-394dc0e778ba/iso-15848-1-2006>

© ISO 2006

All rights reserved. Unless otherwise specified, no part of this publication may be reproduced or utilized in any form or by any means, electronic or mechanical, including photocopying and microfilm, without permission in writing from either ISO at the address below or ISO's member body in the country of the requester.

ISO copyright office
Case postale 56 • CH-1211 Geneva 20
Tel. + 41 22 749 01 11
Fax + 41 22 749 09 47
E-mail copyright@iso.org
Web www.iso.org

Published in Switzerland

Contents

Page

Foreword.....	iv
Introduction	v
1 Scope	1
2 Normative references	1
3 Terms and definitions.....	1
4 Abbreviations	3
5 Type test	4
5.1 Test conditions	4
5.2 Test procedures	7
6 Performances classes	10
6.1 Classification criteria.....	10
6.2 Tightness classes	10
6.3 Endurance classes	11
6.4 Temperature classes	13
6.5 Examples of class designation	14
6.6 Marking	14
7 Reporting	15
8 Extension of qualification to untested valves	16
Annex A (normative) Total leak rate measurement	17
Annex B (normative) Leak measurement using the sniffing method	31
Annex C (informative) Derivation and graphs relating the stem diameter to leak rate.....	40
Bibliography	48

Foreword

ISO (the International Organization for Standardization) is a worldwide federation of national standards bodies (ISO member bodies). The work of preparing International Standards is normally carried out through ISO technical committees. Each member body interested in a subject for which a technical committee has been established has the right to be represented on that committee. International organizations, governmental and non-governmental, in liaison with ISO, also take part in the work. ISO collaborates closely with the International Electrotechnical Commission (IEC) on all matters of electrotechnical standardization.

International Standards are drafted in accordance with the rules given in the ISO/IEC Directives, Part 2.

The main task of technical committees is to prepare International Standards. Draft International Standards adopted by the technical committees are circulated to the member bodies for voting. Publication as an International Standard requires approval by at least 75 % of the member bodies casting a vote.

Attention is drawn to the possibility that some of the elements of this document may be the subject of patent rights. ISO shall not be held responsible for identifying any or all such patent rights.

ISO 15848-1 was prepared by Technical Committee ISO/TC 153, *Valves*, Subcommittee SC 1, *Design, manufacture, marking and testing*.

ISO 15848 consists of the following parts, under the general title *Industrial valves — Measurement, test and qualification procedures for fugitive emissions*:

— *Part 1: Classification system and qualification procedures for type testing of valves*

— *Part 2: Production acceptance test of valves*

<https://standards.iteh.ai/catalog/standards/sist/b84e3735-6494-43e7-9dc2-394dc0e778ba/iso-15848-1-2006>

Introduction

The objective of this part of ISO 15848 is to enable classification of performance of different designs and constructions of valves to reduce fugitive emissions.

This part of ISO 15848 defines type test for evaluation and qualification of valves where fugitive emissions standards are specified.

The procedures of this part of ISO 15848 can only be used with the application of necessary precautions for testing with flammable or inert gas at temperature and under pressure.

iTeh STANDARD PREVIEW (standards.iteh.ai)

[ISO 15848-1:2006](https://standards.iteh.ai/catalog/standards/sist/b84e3735-6494-43e7-9dc2-394dc0e778ba/iso-15848-1-2006)

<https://standards.iteh.ai/catalog/standards/sist/b84e3735-6494-43e7-9dc2-394dc0e778ba/iso-15848-1-2006>

iTeh STANDARD PREVIEW
(standards.iteh.ai)

ISO 15848-1:2006

<https://standards.iteh.ai/catalog/standards/sist/b84e3735-6494-43e7-9dc2-394dc0e778ba/iso-15848-1-2006>

Industrial valves — Measurement, test and qualification procedures for fugitive emissions —

Part 1: Classification system and qualification procedures for type testing of valves

1 Scope

This part of ISO 15848 specifies testing procedures, for evaluation of external leakage of valve stem seals (or shaft) and body joints of isolating valves and control valves intended for application in volatile air pollutants and hazardous fluids. End connection joints, vacuum application, effects of corrosion and radiation are excluded from this part of ISO 15848.

This part of ISO 15848 concerns classification system and qualification procedures for type testing of valves.

2 Normative references

The following referenced documents are indispensable for the application of this document. For dated references, only the edition cited applies. For undated references, the latest edition of the referenced document (including any amendments) applies.

ISO 5208, *Industrial valves — Pressure testing of valves*

3 Terms and definitions

For the purposes of this document, the following terms and definitions apply.

3.1

body seals

any seal in pressure containing part except stem (or shaft) seals

3.2

Class

a convenient round number used to designate pressure-temperature ratings

NOTE It is designated by the word “Class” followed by the appropriate reference number from the following series: Class 125, Class 150, Class 250, Class 300, Class 600, Class 900, Class 1 500, Class 2 500.

3.3

concentration

ratio of test fluid volume to the gas mixture volume measured at the leak source(s) of the test valve

NOTE The concentration is expressed in ppmv (parts per million volume), which is a unit deprecated by ISO (1 ppmv = 1 ml/m³ = 1 cm³/m³).

3.4

control valve

power operated device which changes the fluid flow rate in a process control system and which consists of a valve connected to an actuator that is capable of changing the position of a closure member in the valve in response to a signal from the controlling system

3.5

fugitive emission

any chemical or mixture of chemicals, in any physical form, which represents an unanticipated or spurious leak from equipment on an industrial site

3.6

leakage

loss of the test fluid through the stem (or shaft) seal or body seal(s) of a test valve under the specified test conditions and which is expressed as a concentration or a leak rate

3.7

leak rate

mass flow rate of the test fluid, expressed in $\text{mg}\cdot\text{s}^{-1}$ per meter of the perimeter of the stem

3.8

local leakage

measurement of the test fluid leakage using a probe at the leak source point

3.9

mechanical cycle of control valves

for linear/rotary control valves, test cycles performed at 50 % of stroke/angle with an amplitude of $\pm 10\%$ of full stroke/angle

3.10

mechanical cycle of isolating valves

motion of a valve obturator moving from the fully closed position to the fully open position, and returning to the fully closed position

3.11

nominal size

DN

alphanumeric designation of size for components of a pipework system, which is used for reference purposes and which comprises the letters DN followed by a dimensionless whole number which is directly related to physical size, in millimetres, of the bore or outside diameter of the end connections

NOTE 1 The nominal diameter is designated by the letters DN followed by a number from the following series: 10, 15, 20, 25, 32, 40, 50, 65, 80, 100, 125, 150, 200, 250, 300, 350, 400, etc.

NOTE 2 The number following the letters DN does not represent a measurable value and should not be used for calculation purposes except where specified in the relevant standard.

3.12

nominal pressure

PN

numerical designation which is a convenient rounded number for reference purposes

NOTE 1 All equipment of the same nominal size (DN) designated by the same PN number has the compatible mating dimensions.

NOTE 2 The maximum allowable working pressure depends upon materials, design and working temperatures and should be selected from the pressure/temperature rating tables in the appropriate standards.

NOTE 3 The nominal pressure is designated by the letters PN followed by the appropriate reference number from the following series: 2,5, 6, 10, 16, 20, 25, 40, 50, etc.

3.13**isolating valve**

valve intended for use principally in the closed or open position which may be power actuated or manually operated

3.14**performance class**

level of the performance of a test valve defined by the criteria specified in Clause 6

3.15**room temperature**

temperature in the range of – 29 °C to + 40 °C

3.16**stem
shaft**

valve component extending into the valve shell to transmit the linear/rotary motion from the actuating device to the valve obturator

3.17**stem seal
shaft seal**

component(s) installed around the valve stem (or shaft) to avoid leakage of internal fluids to atmosphere

3.18**test pressure**

pressure used for testing the valve which, unless otherwise specified, shall be the rated pressure specified at the test temperature and the shell material of a test valve in the relevant standards

3.19**test temperature**

fluid temperature selected for the test from Table 3 as measured inside the test valve

3.20**thermal cycle**

change of the temperature from the room temperature to the specified test temperature and return to the room temperature

3.21**total leakage**

collection of leakage of the test fluid at the leak source using an encapsulation method

3.22**type test**

a test conducted to establish the performance class of a valve

4 Symbols and abbreviations

M_{air} predicted maximum leakage

SSA stem (or shaft) seal adjustment

NOTE The abbreviation SSA corresponds to the abbreviation of “Stem Seal Adjustment”.

OD_{stem} external diameter of the stem

RT ambient temperature

5 Type test

5.1 Test conditions

5.1.1 Preparation of a valve to be tested

Only a fully assembled valve shall be used for the test.

A valve shall be selected from standard production at random. The valve shall have been tested and accepted in accordance with ISO 5208 or any other applicable standard and no subsequent protective coating shall have been applied.

Additional seal arrangements to allow the stem sealing system leakage measurement is permitted and shall not affect the sealing performance of the valve.

The test valve interior shall be dried and lubricants (if any) shall be removed. The valve and test equipment shall be clean and free of water, oil and dust and the packing may be changed prior to the test. If the valve packing is changed prior to the test, it should be done under the supervision of the valve manufacturer.

If a test valve is equipped with a manually adjustable stem (or shaft) seal(s), it shall be initially adjusted according to the manufacturer instructions, and recorded in the test report as provided in Clause 7.

The valve manufacturer shall select the appropriate actuating device.

5.1.2 Test fluid

The test fluid shall be helium gas of 97 % minimum purity or methane of 97 % minimum purity. The same test fluid shall be used throughout the test.

5.1.3 Test temperature

Valve mechanical cycling is carried out at the room temperature or in the steps of the room temperature and the selected test temperature other than the room temperature (see 5.2.4.1).

The test temperature shall be recorded for each leakage measurement.

5.1.4 Measurement of test valve temperature

The temperature of the test valve shall be measured at three locations (X, Y, Z), as shown in Figure 1, and recorded in a test report.

- a) Measurement at location "X" shall be used to determine the test temperature.
- b) Measurement at location "Z" is used to determine the external valve temperature adjacent to the stem (or shaft) seal(s) for information.
- c) Measurement at location "Y" is also made for information. Any use of insulation shall be detailed in the test report.

All temperatures at location X, Y and Z shall be stabilized before leakage is measured (see Figure 2). Temperature at location "Z" shall be stabilized for minimum 10 min prior to leakage measurement.

Check if the temperature variation is within ± 5 %.

iTeh STANDARD PREVIEW

(standards.iteh.ai)

ISO 15848-1:2006

<https://standards.iteh.ai/catalog/standards/sist/b84e3735-6494-43e7-9dc2-394dc0e778ba/iso-15848-1-2006>

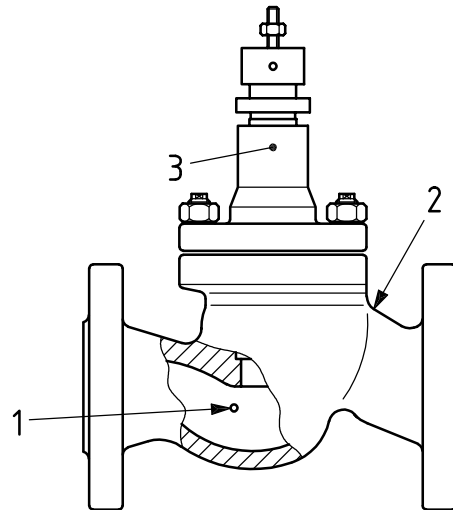
**Key**

- 1 location X: flow path (temperature T_1)
- 2 location Y: valve body (temperature T_2)
- 3 location Z: stuffing box (temperature T_3)

**Figure 1 — Measurements of temperature at three locations
(when the valve is internally heated or cooled)**

(standards.iteh.ai)

ISO 15848-1:2006

<https://standards.iteh.ai/catalog/standards/sist/b84e3735-6494-43e7-9dc2-394dc0e778ba/iso-15848-1-2006>

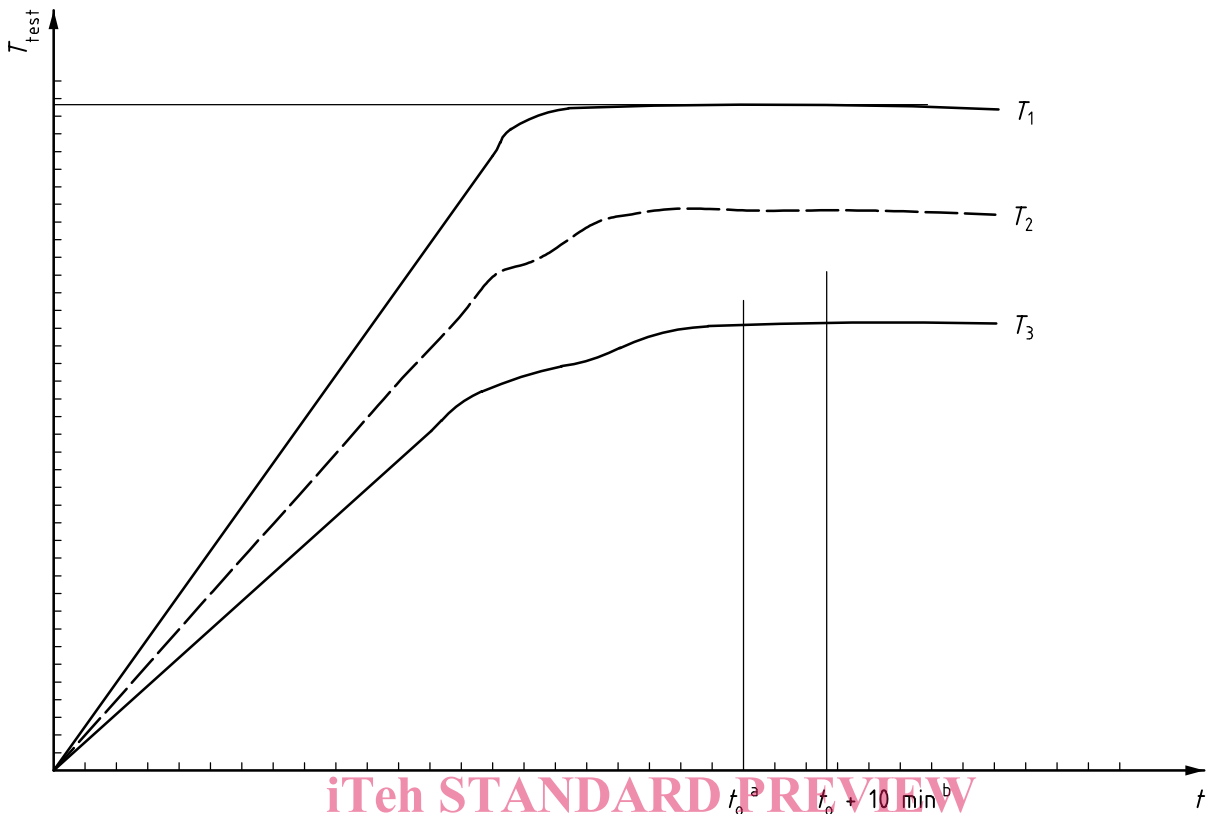

iTeh STANDARD PREVIEW
(standards.iteh.ai)

Key

- T_{test} test temperature, °C
- T_1 stabilization temperature at location X (flow path)
- T_2 stabilization temperature at location Y (valve body)
- T_3 stabilization temperature at location Z (stuffing box)
- t time

- a Stabilization of temperature at location Z (stuffing box).
- b Start of mechanical cycles.

Figure 2 — Stabilization of temperatures

5.1.5 Leakage measurement

5.1.5.1 Stem (or shaft) leakage measurement

Leakage shall be measured from a test valve at rest in the partly open position.

The leakage measurement shall be performed by the global method (flushing or vacuum) according to the procedures described in Annex A.

5.1.5.2 Body seal leakage measurement

The leakage shall be measured by the sniffing method according to the procedure described in Annex B and expressed in parts per million volume (1 ppmv = 1 ml/m³ = 1 cm³/m³).

Evaluation of the end connections should be done to insure that they do not affect the results of the evaluation of the body seals.

5.1.5.3 Leakage-measurement records

All results of leakage measurements shall be recorded in a test report as specified in Clause 7.

5.2 Test procedures

5.2.1 Safety rules

Testing with high pressure gas is potentially hazardous and thus all applicable local safety rules and adequate safety measures shall be followed. If methane (CH₄) is used, the combination of the test pressure and temperature shall be reviewed for possible combustion concerns.

5.2.2 Test equipment

The test equipment shall be appropriately selected to

- a) apply and maintain the test pressure within a range of $\pm 5\%$ of the nominal value;
- b) apply valve mechanical cycles;
- c) heat or cool the test valve to the selected test temperature, and maintain it within a range of $\pm 5\%$ but not exceeding 15°C; no mechanical cycling is permitted during temperature change;
- d) measure and record time, pressure, temperature, leakage and duration of a valve mechanical cycle;
- e) measure and record actuation forces or torques to operate a test valve;
- f) measure and record the stem sealing system loading, if applicable.

5.2.3 Stem (or shaft) seal adjustment (SSA)

5.2.3.1 Number of stem seal adjustment

Mechanical adjustments of stem (or shaft) sealing system during the type test shall be permitted only once, as shown below, for each of qualification stage done according to Figures 3 and 4, if stem (or shaft) leakage has been measured in excess of the target tightness class selected from Tables 1 or 2.

The maximum re-tightening force (or torque) to apply shall be determined prior to the type test.

- EXAMPLE
- A maximum of one adjustment is accepted for CC1 or CO1;
 - A maximum of two adjustments is accepted for CC2 or CO2.

5.2.3.2 Test failure after stem seal adjustment

If a stem (or shaft) sealing arrangement fails to achieve the target tightness class, or it is not possible to continue mechanical cycling, the test shall be considered terminated, and the test valve shall be evaluated for qualification of lower tightness and endurance classes, if applicable.

5.2.3.3 Reporting the number of SSA

The total number of stem (or shaft) seal adjustment shall be recorded in the test report and indicated in the designation of the valve classification as "SSA-1", "SSA-2" and so forth.

5.2.4 Test description

5.2.4.1 General

The test description is the following.

- a) The test valve shall be mounted on a test rig, according to the instructions given by the manufacturer.
- b) The valve mounting shall be principally made with a stem (or shaft) positioned vertical. A valve intended for use in other positions shall be mounted with the stem (or shaft) positioned horizontally.
- c) All sealing systems shall have been properly adjusted beforehand, according to the manufacturer's instructions. For valves using packings as a stem seal, the tightening torque of the gland boltings shall be measured and recorded at the beginning of the test and after any stem seal adjustment.
- d) The target number and combination of mechanical and thermal cycles shall be selected from the endurance classes specified in Figures 3 and 4.
- e) Leakage from the stem (or shaft) seal and from the body seals shall be separately measured. If the valve does not allow such a separate measurement the total leakage of both stem (or shaft) and body seals shall be measured at the same time according to Annex A.
- f) Actual methods of mechanical cycles other than those specified in 5.2.4.2 and 5.2.4.3 shall be in accordance with the manufacturer's instructions, and opening, closing and dwelling time shall be recorded in the test report. Basically, they shall represent the intended operating conditions of a test valve.
- g) Valve opening and closing force (or torque) shall be measured and recorded at the start and at the end of the test, following subsequent stem seal adjustments if applicable.

5.2.4.2 Mechanical cycles of isolating valves ISO 15848-1:2006

[https://standards.iteh.ai/catalog/standards/sist/b84e3735-6494-43e7-9dc2-](https://standards.iteh.ai/catalog/standards/sist/b84e3735-6494-43e7-9dc2-3041e2587e5c/iso-15848-1-2006)

Unless otherwise specified by the valve manufacturer, the valve seating force (or torque) required for tightness under a differential pressure of 0,6 MPa (6 bar), air or inert gas shall be used as the minimum force (or torque) for mechanical cycle of a test valve.

Fully back seating a test valve is not required.

5.2.4.3 Mechanical cycles of control valves

The stem motion of linear action valves shall be between 1 mm/s and 5 mm/s. The shaft motion of rotary control valves shall be between 1°/s and 5°/s.

The actuator to operate a test valve shall withstand only the pressure and friction force (or torque) acting on the valve stem, and these values shall be recorded.

NOTE Measurement of friction force (or torque) is principally intended to check the packing friction usually expressed as the dead band.

5.2.4.4 Preliminary tests at the room temperature (test 1)

The tests are carried out as shown below.

- a) Pressurize a test valve with the test fluid to the test pressure as specified in a relevant standard.
- b) After the test pressure has been stabilized, measure leakages both from the stem (or shaft) seal and from the body seals, in accordance with Annexes A and B, respectively.
- c) Record the test result in a test report.

5.2.4.5 Mechanical cycle test at the room temperature (test 2)

The tests are carried out as shown below.

- a) Perform mechanical cycles at room temperature while the test valve is kept pressurized.
- b) Measure the leakage from the stem (or shaft) seal only, in accordance with Annex A.
- c) Record the test result in the test report.
- d) Repeat the test in case of Class CO1 and CC1, as indicated in Figures 3 and 4.

5.2.4.6 Static test at the selected test temperature (test 3)

The tests are carried out as shown below.

- a) Pressurize a test valve with the test fluid to the test pressure as specified in a relevant standard for the selected test temperature selected from Table 3.
- b) After the test pressure has been stabilized, adjust the valve temperature to the selected test temperature, ensuring that the test pressure does not exceed the level specified in the relevant standard.
- c) After the valve temperature has been stabilized with an allowance of $\pm 5\%$ with a maximum of $15\text{ }^{\circ}\text{C}$, measure the leakage from the stem (or shaft) seal only in accordance with Annex A.
- d) Record the test result in the test report.
- e) Repeat the test in case of Class CO1 and CC1, as indicated in Figures 3 and 4.

5.2.4.7 Mechanical cycle test at the selected test temperature (test 4)

The tests are carried out as shown below. [ISO 15848-1:2006](https://standards.iteh.ai/catalog/standards/sist/b84e3735-6494-43e7-9dc2-)
<https://standards.iteh.ai/catalog/standards/sist/b84e3735-6494-43e7-9dc2->

- a) Perform mechanical cycles at the selected test temperature while the test valve is kept pressurized.
- b) Measure the leakage from the stem (or shaft) seal only in accordance with Annex A.
- c) Record the test result in a test report.
- d) Repeat the test in case of Class CO1 and CC1, as indicated in Figures 3 and 4.

5.2.4.8 Intermediate static test at the room temperature (test 5)

The tests are carried out as shown below.

- a) Allow a test valve to return to the room temperature, without artificial cooling (or heating).
- b) After the valve temperature has been stabilized, measure the leakage from the stem (or shaft) seal only in accordance with Annex A.
- c) Record the test result in a test report.

5.2.4.9 Final test at the room temperature (test 6)

The tests are carried out as shown below.

- a) Allow a test valve to return to the room temperature, without artificial measures.
- b) After the valve temperature has been stabilized, measure the leakage from the stem (or shaft) seal in accordance with Annex A and from body seals in accordance with Annex B.
- c) Record the test results in the test report.