



SLOVENSKI STANDARD
SIST EN 1034-1:2000/kFprA1:2009
01-november-2009

Varnost strojev - Varnostne zahteve za načrtovanje in konstrukcijo strojev in opreme za izdelavo papirja - 1. del: Splošne zahteve

Safety of machinery - Safety requirements for the design and construction of paper making and finishing machines - Part 1: Common requirements

Sicherheit von Maschinen - Sicherheitstechnische Anforderungen für Konstruktion und Bau von Maschinen der Papierherstellung und Ausrüstung - Teil 1: Gemeinsame Anforderungen

Sécurité des machines - Prescriptions de sécurité pour la conception et la construction de machines de fabrication et de finition du papier - Partie 1: Prescriptions communes

Ta slovenski standard je istoveten z: EN 1034-1:2000/FprA1

ICS:

13.110	Varnost strojev	Safety of machinery
21.020	Značilnosti in načrtovanje strojev, aparatov, opreme	Characteristics and design of machines, apparatus, equipment
85.100	Oprema za papirno industrijo	Equipment for the paper industry

SIST EN 1034-1:2000/kFprA1:2009 **en,fr,de**

EUROPEAN STANDARD
NORME EUROPÉENNE
EUROPÄISCHE NORM

FINAL DRAFT
EN 1034-1:2000

FprA1

July 2009

ICS 85.100

English Version

**Safety of machinery - Safety requirements for the design and
construction of paper making and finishing machines - Part 1:
Common requirements**

Sécurité des machines - Prescriptions de sécurité pour la
conception et la construction de machines de fabrication et
de finition du papier - Partie 1: Prescriptions communes

Sicherheit von Maschinen - Sicherheitstechnische
Anforderungen für Konstruktion und Bau von Maschinen
der Papierherstellung und Ausrüstung - Teil 1:
Gemeinsame Anforderungen

This draft amendment is submitted to CEN members for unique acceptance procedure. It has been drawn up by the Technical Committee CEN/TC 198.

This draft amendment A1, if approved, will modify the European Standard EN 1034-1:2000. If this draft becomes an amendment, CEN members are bound to comply with the CEN/CENELEC Internal Regulations which stipulate the conditions for inclusion of this amendment into the relevant national standard without any alteration.

This draft amendment was established by CEN in three official versions (English, French, German). A version in any other language made by translation under the responsibility of a CEN member into its own language and notified to the CEN Management Centre has the same status as the official versions.

CEN members are the national standards bodies of Austria, Belgium, Bulgaria, Cyprus, Czech Republic, Denmark, Estonia, Finland, France, Germany, Greece, Hungary, Iceland, Ireland, Italy, Latvia, Lithuania, Luxembourg, Malta, Netherlands, Norway, Poland, Portugal, Romania, Slovakia, Slovenia, Spain, Sweden, Switzerland and United Kingdom.

Warning : This document is not a European Standard. It is distributed for review and comments. It is subject to change without notice and shall not be referred to as a European Standard.



EUROPEAN COMMITTEE FOR STANDARDIZATION
COMITÉ EUROPÉEN DE NORMALISATION
EUROPÄISCHES KOMITEE FÜR NORMUNG

Management Centre: Avenue Marnix 17, B-1000 Brussels

Contents		Page
Foreword.....		3
1	Modifications to the Foreword	4
2	Modifications to Clause 2	4
3	Modification to Clause 3	5
4	Modification to Clause 4	5
5	Modifications to Clause 5	5
6	Modifications to Clause 7	8
7	Modification to Annex ZA	9
8	Addition of Annex ZB	9
9	Addition of Bibliography	11
Bibliography		11

Foreword

This document (EN 1034-1:2000/FprA1:2009) has been prepared by CEN /TC 198 "Printing and paper machinery — Safety" the secretariat of which is held by DIN.

This document is currently submitted to the Unique Acceptance Procedure.

This document has been prepared under a mandate given to CEN by the European Commission and the European Free Trade Association, and supports essential requirements of EU Directive(s).

For relationship with EU Directive(s), see informative Annexes ZA and ZB, which are integral parts of this document.

EN 1034-1:2000/FprA1:2009 (E)**1 Modifications to the Foreword**

In the list of parts of this European Standard, replace "Part 7: Paper making machines" with "Part 7: Chests".

Add the following parts to the list of parts of this European Standard:

"Part 13: Machines for de-wiring bales and units

Part 14: Reel splitter

Part 16: Paper and board making machines

Part 17: Tissue making machines

Part 21: Coaters

Part 22: Wood grinders".

2 Modifications to Clause 2

Replace the 1st paragraph with the following:

"The following referenced documents are indispensable for the application of this document. For dated references, only the edition cited applies. For undated references, the latest edition of the referenced document (including any amendments) applies."

Delete EN 292-1:1991 and add "EN ISO 12100-1:2003, Safety of machinery — Basic concepts, general principles for design — Part 1: Basic terminology, methodology (ISO 12100-1:2003)",

Delete EN 292-2:1991/A1:1995 and add "EN ISO 12100-2:2003, Safety of machinery — Basic concepts, general principles for design — Part 2: Technical principles (ISO 12100-2:2003)",

Delete EN 294:1992 and add "EN ISO 13857:2008, Safety of machinery — Safety distances to prevent hazard zones being reached by upper and lower limbs (ISO 13857:2008)",

Delete EN 418 and add "EN ISO 13850:2008, Safety of machinery — Emergency stop — Principles for design (ISO 13850:2006)",

Delete EN 563 and add "EN ISO 13732-1:2008, Ergonomics of the thermal environment — Methods for the assessment of human responses to contact with surfaces — Part 1: Hot surfaces (ISO 13732-1:2006)".

Add "EN 809 Pumps and pump units for liquids — Common safety requirements".

Delete EN 954-1 and add "EN ISO 13849-1:2008, Safety of machinery — Safety-related parts of control systems — Part 1: General principles for design (ISO 13849-1:2006)".

Delete ENV 1070:1993.

Delete prEN 12437-1,

Delete prEN 12437-2,

Delete prEN 12437-3 and add "EN ISO 14122-3, Safety of machinery — Permanent means of access to machinery — Part 3: Stairs, stepladders and guard-rails (ISO 14122-3:2001)",

Delete prEN 12437-4 and add "EN ISO 14122-4, Safety of machinery — Permanent means of access to machinery — Part 4: Fixed Ladders (ISO 14122-4:2004)".

Delete prEN 13023 and add "EN 13023:2003, Noise measurement methods for printing, paper converting, paper making machines and auxiliary equipment — Accuracy grades 2 and 3".

Delete EN 60204-1:1992 and add "EN 60204-1:2006, Safety of machinery — Electrical equipment of machines — Part 1: General requirements (IEC 60204-1:2005, modified)",

Delete EN 1050 and add "EN ISO 14121-1:2007, Safety of machinery – Risk assessment – Part 1: Principles (ISO 14121-1:2007)".

Delete prEN ISO 11688-1 and add "EN ISO 11688-1:1998, Acoustics – Recommended practice for the design of low-noise machinery and equipment – Part 1: Planning (ISO/TR 11688-1:1995)".

Add:

"EN 13478:2001, Safety of machinery — Fire prevention and protection",

"EN 61511-1:2004, Functional safety — Safety instrumented systems for the process industry sector — Part 1: Framework, definitions, system, hardware and software requirements (IEC 61511-1:2003 + Corrigendum 2004)",

"EN 62061:2005, Safety of machinery — Functional safety of safety-related electrical, electronic and programmable electronic control systems (IEC 62061:2005)".

3 Modification to Clause 3

In the 1st paragraph replace "EN 292-1:1991, EN 1070:1993" with "EN ISO 12100-1:2003".

4 Modification to Clause 4

In the 1st paragraph, delete "in accordance with EN 1050".

Throughout Table 1, replace "EN 1050 Annex A" with "EN ISO 14121-1".

5 Modifications to Clause 5

In the 2nd paragraph of 5, replace "EN 292" with "EN ISO 12100-2:2003".

In the 1st paragraph of 5.1.1 replace "4.2 of EN 292:1991" with "5 of EN ISO 12100-2:2003".

Add the following paragraphs at the end of 5.1.1:

"Guards and protective devices shall be securely held in place in accordance with 5.4.2 and 5.5 of EN 953.

Fixed guards that have to be removed periodically for maintenance (e. g. the guards on wrapping points of rolls for changing clothing) shall be constructed in such a way that their fixing systems remain attached to the guards or to the machinery when the guards are removed. An example is shown in Figure 11 of EN 953.

EN 1034-1:2000/FprA1:2009 (E)

Where possible, guards shall be constructed in such a way that they also protect against ejected or falling materials and objects.

Where possible, guards shall be constructed in such a way that they also protect against emissions generated by the machinery, for example against noise."

In 5.1.2, Replace "3.22.5 and 3.22.4 of EN 292-1:1991" with "3.6 or 3.5 of EN 953:1997".

In 5.2, replace "Table 2 of EN 294:1992 and Table A.1 of EN 811:1996" with "Table 2 and Table B.1 of EN ISO 13857:2008".

In the last paragraph of 5.4.1, replace "EN 294:1992" with "EN ISO 13857:2008" in two places.

In the title of Figure 4, Replace "EN 294" with "EN ISO 13857:2008".

In the 1st paragraph of 5.4.2, replace "EN 294" with "EN ISO 13857:2008".

Throughout Table 3, replace "EN 12437-3" by "EN ISO 14122-3" and "EN 12437-4" by "EN ISO 14122-4".

Replace Figure 6 with the following: "

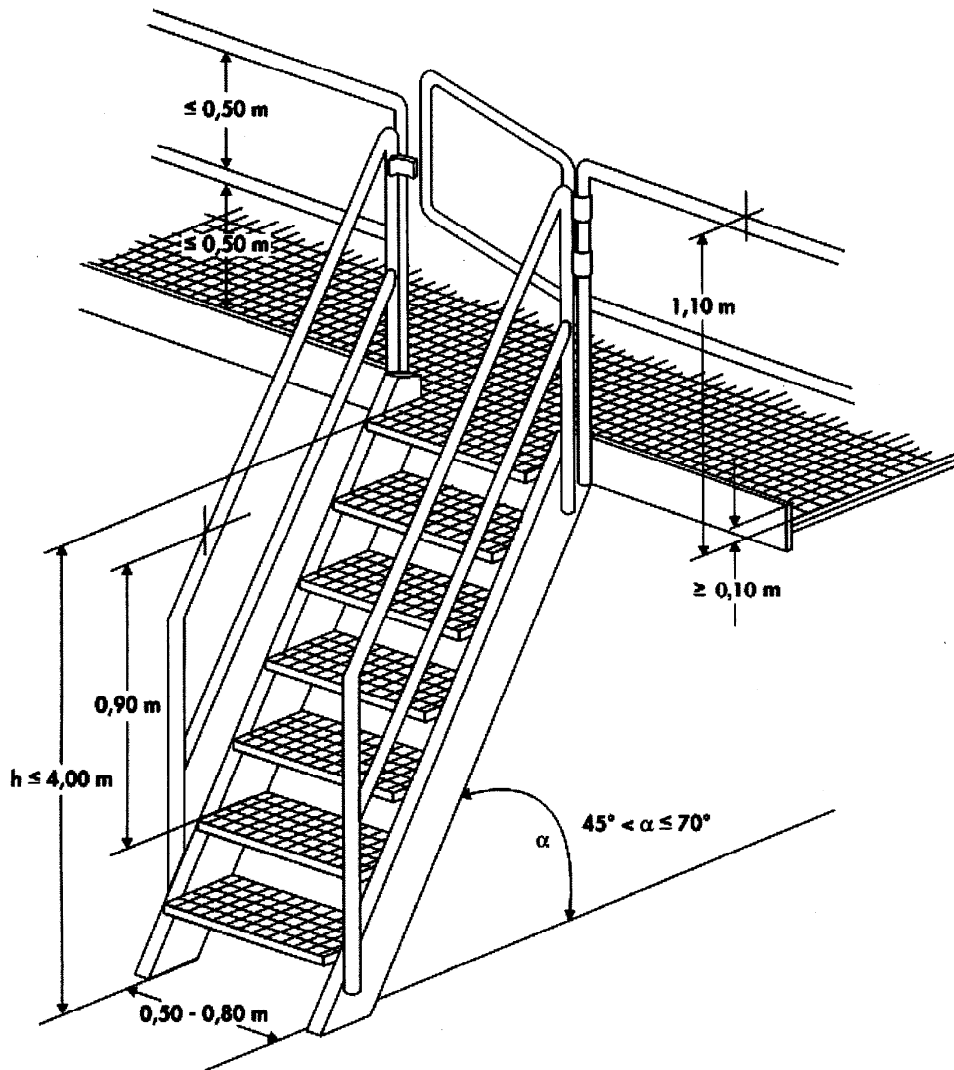

"

In the 1st paragraph of 5.6.2, replace "Category 2 of EN 954-1" with "the Safety Integrity Level SIL 1 of EN 62061:2005 or the Performance Level PL c of EN ISO 13849-1:2008".

In the 1st paragraph, 1st sentence of 5.7, replace "6.1.1 of EN 292-2:1991" with "5.5.2 of EN ISO 12100-2:2003".

In the 1st paragraph, 2nd sentence of 5.7, replace "EN 418" with "EN ISO 13850".

Add the following new paragraph at the end of 5.7:

"The emergency stop function shall be available and operational at all times, regardless of the operating mode. Emergency stop devices shall be designed to back-up other safeguarding measures and not to substitute them."

In the 1st paragraph, 2nd sentence of 5.8.1, replace "EN 60204-1:1992" with "EN 60204-1:2006" and "6.2.2 of EN 292-2" with "5.5.4 of EN 12100-2:2003".

Throughout Table 5, replace "EN 60204-1:1992" with "EN 60204-1:2006" and "6.2.3 of EN 60204-1:1992" with "6.2.4 of EN 60204-1:2006".

In the 1st paragraph of 5.8.2, replace "EN 60204-1:1992" with "EN 60204-1:2006".

In the 2nd sentence of 5.8.4, replace "EN 60204-1:1992" with "EN 60204-1:2006".

Add the following new 5.8.5: "

5.8.5 When a part of the machinery has been stopped, any drift away from the stopping position, for whatever reason other than actuation of the control device(s), shall be prevented or the machine shall be designed and constructed in such way that the drift away does not present a hazard.

NOTE Brakes, self arresting gears or automatic retaining pawls are examples of means for stopping movements."

In 5.9.5, replace "3.7.10 of EN 292-2:1991" with "5.2.4 of EN 12100-2:2003".

Add the following new paragraph at the end of 5.14.1:

"Control devices shall be designed and marked in such way that they are clearly visible and identifiable, using pictograms where appropriate, for example using marking in accordance to 10.2.2 of EN 60204-1:2006."

In 5.14.2 replace "EN 954-1" with "EN ISO 13849-1:2008, EN 62061:2005 and/or EN 61511-1:2004".

Add the following at the end of 5.14.2:

"NOTE Where, in published standards of the EN 1034 series, safety related controls require a Category to be specified in accordance with EN 954-1, the following table may be used to determine the approximate relationship between the Safety Integrity Level SIL of EN 62061:2005 and the Performance Level PL of EN ISO 13849-1:2008.

Category of EN 954-1	1	2	3	4
Safety Integrity Level of EN 62061:2005	SIL 1	SIL 1	SIL 2	SIL 3
Performance Level of EN ISO 13849-1:2008	PL b	PL c	PL d	PL e

In 5.14.4, 1st sentence, replace "category 1 or category 2 of EN 954-1" with "the Safety Integrity Level SIL 1 of EN 62061:2005 or the Performance Level PL c of EN ISO 13849-1:2008".