**Connections for fluid power and general
use — Hydraulic couplings for diagnostic
purposes —**

Part 2:

**Coupling with M16 × 2 end for connection
under pressure**

iTeh STANDARDS PREVIEW
(standards.iteh.ai)

*Raccordements pour transmissions hydrauliques et pneumatiques et usage
général — Raccords hydrauliques pour diagnostics —*

ISO 15171-2:2000

Partie 2: Raccord avec extrémité M16 × 2 pour connexion sous pression
<https://standards.iteh.ai/catalog/standards/sist/2000-11-01/iso-15171-2-2000/2ea8775142e4/iso-15171-2-2000>



PDF disclaimer

This PDF file may contain embedded typefaces. In accordance with Adobe's licensing policy, this file may be printed or viewed but shall not be edited unless the typefaces which are embedded are licensed to and installed on the computer performing the editing. In downloading this file, parties accept therein the responsibility of not infringing Adobe's licensing policy. The ISO Central Secretariat accepts no liability in this area.

Adobe is a trademark of Adobe Systems Incorporated.

Details of the software products used to create this PDF file can be found in the General Info relative to the file; the PDF-creation parameters were optimized for printing. Every care has been taken to ensure that the file is suitable for use by ISO member bodies. In the unlikely event that a problem relating to it is found, please inform the Central Secretariat at the address given below.

iTeh STANDARD PREVIEW
(standards.iteh.ai)

[ISO 15171-2:2000](https://standards.iteh.ai/catalog/standards/sist/7203c444-b30d-4578-8f81-2ea8775142e4/iso-15171-2-2000)

<https://standards.iteh.ai/catalog/standards/sist/7203c444-b30d-4578-8f81-2ea8775142e4/iso-15171-2-2000>

© ISO 2000

All rights reserved. Unless otherwise specified, no part of this publication may be reproduced or utilized in any form or by any means, electronic or mechanical, including photocopying and microfilm, without permission in writing from either ISO at the address below or ISO's member body in the country of the requester.

ISO copyright office
Case postale 56 • CH-1211 Geneva 20
Tel. + 41 22 749 01 11
Fax + 41 22 749 09 47
E-mail copyright@iso.ch
Web www.iso.ch

Printed in Switzerland

Foreword

ISO (the International Organization for Standardization) is a worldwide federation of national standards bodies (ISO member bodies). The work of preparing International Standards is normally carried out through ISO technical committees. Each member body interested in a subject for which a technical committee has been established has the right to be represented on that committee. International organizations, governmental and non-governmental, in liaison with ISO, also take part in the work. ISO collaborates closely with the International Electrotechnical Commission (IEC) on all matters of electrotechnical standardization.

International Standards are drafted in accordance with the rules given in the ISO/IEC Directives, Part 3.

Draft International Standards adopted by the technical committees are circulated to the member bodies for voting. Publication as an International Standard requires approval by at least 75 % of the member bodies casting a vote.

Attention is drawn to the possibility that some of the elements of this part of ISO 15171 may be the subject of patent rights. ISO shall not be held responsible for identifying any or all such patent rights.

International Standard ISO 15171-2 was prepared by Technical Committee ISO/TC 131, *Fluid power systems*, Subcommittee SC 4, *Connectors and similar products and components*.

ISO 15171 consists of the following parts, under the general title *Connections for fluid power and general use — Hydraulic couplings for diagnostic purposes*:

- Part 1: Coupling not for connection under pressure
- Part 2: Coupling with M16 × 2 end for connection under pressure

[ISO 15171-2:2000](https://standards.iteh.ai/catalog/standards/sist/7203c444-b30d-4578-8f81-2ea8775142e4/iso-15171-2-2000)

<https://standards.iteh.ai/catalog/standards/sist/7203c444-b30d-4578-8f81-2ea8775142e4/iso-15171-2-2000>

Introduction

In hydraulic fluid power systems, power is transmitted and controlled through a liquid under pressure within an enclosed circuit. In general applications, a fluid may be conveyed under pressure.

Components are equipped with ports providing diagnostic points in a hydraulic system. Diagnostic couplings may be installed to aid in the diagnosis of hydraulic systems.

iTeh STANDARD PREVIEW (standards.iteh.ai)

ISO 15171-2:2000

<https://standards.iteh.ai/catalog/standards/sist/7203c444-b30d-4578-8f81-2ea8775142e4/iso-15171-2-2000>

Connections for fluid power and general use — Hydraulic couplings for diagnostic purposes —

Part 2:

Coupling with M16 × 2 end for connection under pressure

1 Scope

This part of ISO 15171 specifies dimensions, performance requirements and test procedures for a diagnostic coupling with an M14 × 1,5 straight stud end to mate with an ISO 6149-1 port and an M16 × 2 connection end that can be connected under pressure without tools to a maximum pressure of 40 MPa [400 bar¹⁾]. The dimensions of the coupling counterpart are specified. The coupling is designed for use in hydraulic systems that use mineral oil.

NOTE The use of this coupling with fluids other than mineral oil requires an agreement between the supplier and the purchaser.

Couplings in accordance with this part of ISO 15171 may be used at a maximum working pressure of 63 MPa (630 bar). The permissible working pressure depends upon the materials, design, working conditions, application, etc.

iTeh STANDARD PREVIEW

Conformance to the dimensional information in this part of ISO 15171 does not guarantee rated performance. Each manufacturer should perform testing according to the specification contained in this part of ISO 15171 to assure that components comply with the performance rating.

ISO 15171-2:2000

<https://standards.iteh.ai/catalog/standards/sist/7203c444-b30d-4578-8f81-2ea8775142e4/iso-15171-2-2000>

2 Normative references

The following normative documents contain provisions which, through reference in this text, constitute provisions of this part of ISO 15171. For dated references, subsequent amendments to, or revisions of, any of these publications do not apply. However, parties to agreements based on this part of ISO 15171 are encouraged to investigate the possibility of applying the most recent editions of the normative documents indicated below. For undated references, the latest edition of the normative document referred to applies. Members of ISO and IEC maintain registers of currently valid International Standards.

ISO 261:1998, *ISO general-purpose metric screw threads — General plan.*

ISO 965-1:1998, *ISO general-purpose metric screw threads — Tolerances — Part 1: Principles and basic data.*

ISO 1629:1995, *Rubber and latices — Nomenclature.*

ISO 5598:1985, *Fluid power systems and components — Vocabulary.*

ISO 6149-1:—²⁾, *Connections for fluid power and general use — Ports and stud ends with ISO 261 threads and O-ring sealing — Part 1: Ports with O-ring seal in truncated housing.*

ISO 6149-2:—³⁾, *Connections for fluid power and general use — Ports and stud ends with ISO 261 threads and O-ring sealing — Part 2: Dimensions, design, test methods and requirements for heavy-duty (S series) stud ends.*

1) 1 bar = 0,1 MPa = 10⁵ Pa; 1 Pa = 1 N/m²

2) To be published. (Revision of ISO 6149-1:1993)

3) To be published. (Revision of ISO 6149-2:1993)

ISO 7241-2:2000, *Hydraulic fluid power — Quick-action couplings — Part 2: Test methods.*

ISO 8434-5:1995, *Metallic tube connections for fluid power and general use — Part 5: Test methods for threaded hydraulic fluid power connections.*

ISO 9227:1990, *Corrosion tests in artificial atmospheres — Salt spray tests.*

3 Terms and definitions

For the purposes of this part of ISO 15171, the terms and definitions given in ISO 5598 apply.

4 Performance requirements

4.1 Working pressure and temperature

Couplings shall be designed for use at a maximum working pressure of 63 MPa (630 bar) within a temperature range from -20°C to $+120^{\circ}\text{C}$.

NOTE The temperature range of couplings with elastomeric seals depends on the limits of the temperature range of the seals.

4.2 Flow rate and pressure drop

4.2.1 At a flow rate of 6 l/min, the pressure drop of the diagnostic coupling shall not exceed 20 MPa (200 bar).

4.2.2 The value of the pressure drop does not include the pressure drop for the hose pin, which is necessary in order to carry out the measurements. The pressure drop test shall be conducted in accordance with ISO 7241-2 and the special provisions given in 4.2.2.1 to 4.2.2.3.

4.2.2.1 Conduct a pressure drop test with the complete coupling.

4.2.2.2 Conduct a pressure drop test with the poppet and spring removed from the coupling.

4.2.2.3 Subtract the value of the pressure drop obtained from 4.2.2.2 from the pressure drop obtained from 4.2.2.1. The result is the net pressure drop.

NOTE The rating of the male half of the coupling is to be considered without the pressure drop of the pin.

4.3 Connection of the coupling with a coupling counterpart

If a coupling counterpart is used as described in clause 5, it shall be ensured that the coupling is sealed before the pin opens the male coupling half.

The thread engagement between both parts shall be not less than two pitches before opening.

4.4 Burst and cyclic endurance (impulse) test pressures

Couplings shall meet at least a burst pressure of 252 MPa (2 520 bar) and a cyclic endurance (impulse) pressure of 84 MPa (840 bar) when tested in accordance with 4.5.

4.5 Test methods

Testing shall be conducted in accordance with ISO 8434-5 for burst, cyclic endurance (impulse) and vacuum tests.

The test samples shall be tightened to a torque in accordance with ISO 6149-2.

The coupling shall meet the requirements:

- without any cap;
- assembled with a protection cap;
- assembled with the coupling counterpart.

After the cyclic endurance test, it shall be possible to disconnect and re-connect the coupling without leakage or malfunction. The results shall be reported using the form given in ISO 8434-5:1995.

5 Design

Dimensions of the coupling shall conform to those given in Figure 1. Stud end and O-ring shall be in accordance with ISO 6149-2.

The dimensions for the coupling counterpart are shown in Figure 2.

The threads are in conformity with ISO 261, tolerance grade 6g for external and 6H for internal thread in accordance with ISO 965-1.

Unless otherwise agreed upon between the supplier and the purchaser, the delivery includes the protection cap and the seal on the stud end.

Dimensions in millimetres

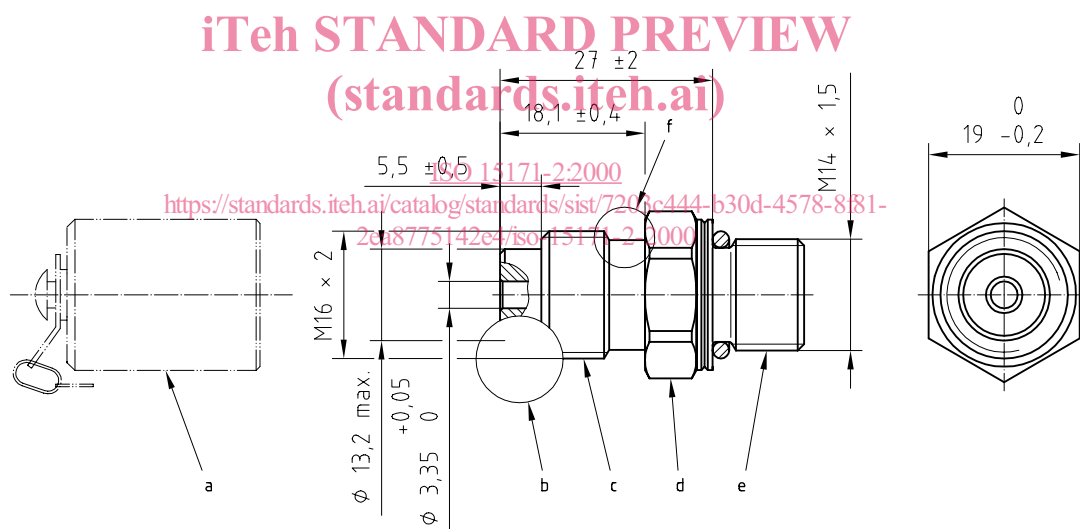

- a Design of the cap at the discretion of the manufacturer
- b Design at the discretion of the manufacturer
- c Diagnostic connection
- d Optional design
- e Stud end and O-ring in accordance with ISO 6149-2
- f Vibration lock at the discretion of the manufacturer

Figure 1 — Diagnostic coupling

Dimensions in millimetres,
surface roughness in micrometres

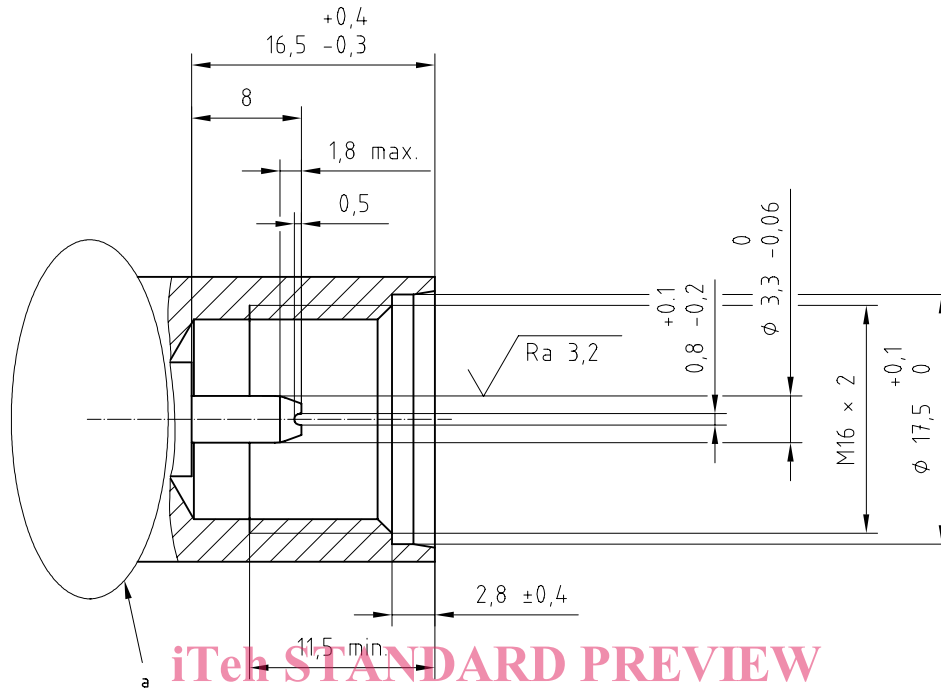

^a Design at the discretion of the manufacturer

Figure 2 — Dimensions for diagnostic coupling counterpart

ISO 15171-2:2000

<https://standards.iteh.ai/catalog/standards/sist/7203c444-b30d-4578-8f81-2ea8775142e4/iso-15171-2-2000>

6 Manufacture

6.1 Construction

Couplings may be made by forging or be machined from bar stock.

6.2 Workmanship

Workmanship shall conform to the best commercial practice to produce high-quality parts. Couplings shall be free from visual contaminants, all hanging burrs, loose scale and slivers that might be dislodged in use, and any other defects that might affect the functioning of the parts. Unless otherwise specified, surface finish on all surfaces shall be $Ra \leq 6,3 \mu\text{m}$.

6.3 Finish

The external surface and threads on all couplings shall pass a minimum 72 h salt spray test in accordance with ISO 9227, unless otherwise agreed upon between supplier and purchaser. Any appearance of red rust during the salt spray test shall be considered failure. Fluid passages shall be excluded from plating or coating requirements but shall be protected with a rust inhibitor.

Corrosion protection requirements do not apply to corners or edges, such as hex points, serrations and the crests of threads.

7 Designation of couplings

When ordering couplings conforming to this part of ISO 15171 a designation consisting of the number of this part of ISO 15171, followed by a spaced hyphen, followed by the material designation, in accordance with ISO 1629, of the required sealing of the stud end, shall be used.

EXAMPLE ISO 15171-2 - NBR

8 Marking

Couplings shall be permanently marked with the manufacturer's name or trademark.

9 Identification statement (reference to this part of ISO 15171)

Use the following statement in test reports, catalogues and sales literature when electing to comply with this part of ISO 15171:

“Coupling for diagnostic purposes in accordance with ISO 15171-2:2000, *Connections for fluid power and general use — Hydraulic coupling for diagnostic purposes — Part 2: Coupling with M16 × 2 end for connection under pressure.*”

iTeh STANDARD PREVIEW
(standards.iteh.ai)

[ISO 15171-2:2000](https://standards.iteh.ai/catalog/standards/sist/7203c444-b30d-4578-8f81-2ea8775142e4/iso-15171-2-2000)

<https://standards.iteh.ai/catalog/standards/sist/7203c444-b30d-4578-8f81-2ea8775142e4/iso-15171-2-2000>