



# Standard Test Method for Hydrocarbon Types, Oxygenated Compounds and Benzene in Spark Ignition Engine Fuels by Gas Chromatography<sup>1</sup>

This standard is issued under the fixed designation D 6839; the number immediately following the designation indicates the year of original adoption or, in the case of revision, the year of last revision. A number in parentheses indicates the year of last reapproval. A superscript epsilon ( $\epsilon$ ) indicates an editorial change since the last revision or reapproval.

## 1. Scope

1.1 This test method provides for the quantitative determination of saturates, olefins, aromatics and oxygenates in spark-ignition engine fuels by multidimensional gas chromatography. Each hydrocarbon type can be reported either by carbon number (see Note 1) or as a total.

NOTE 1—There can be an overlap between the C<sub>9</sub> and C<sub>10</sub> aromatics; however, the total is accurate. Isopropyl benzene is resolved from the C<sub>8</sub> aromatics and is included with the other C<sub>9</sub> aromatics.

1.2 This test method is applicable to spark-ignition engine fuel with total aromatic content up to 50 % (V/V), total olefinic content up to 30 % (V/V) and oxygen compounds up to 15 % (V/V).

1.3 This test method is not intended to determine individual hydrocarbon components except benzene.

1.4 Oxygenates as specified in Test Method D 4815 have been verified not to interfere with hydrocarbons. Within the round robin sample set, the following oxygenates have been tested: MTBE, ethanol, ETBE, and TAME. Other oxygenates can be determined and quantified using Test Method D 4815 or D 5599.

1.5 The values stated in SI units are to be regarded as the standard.

1.6 *This standard does not purport to address all of the safety concerns, if any, associated with its use. It is the responsibility of the user of this standard to establish appropriate safety and health practices and determine the applicability of regulatory limitations prior to use.*

## 2. Referenced Documents

### 2.1 ASTM Standards:

D 4307 Practice for Preparation of Liquid Blends for Use as Analytical Standards<sup>2</sup>

D 4815 Test Method for Determination of MTBE, ETBE, TAME, DIPE tertiary-Amyl Alcohol and C<sub>1</sub> to C<sub>4</sub> Alcohols in Gasoline by Gas Chromatography<sup>2</sup>

<sup>1</sup> This test method is under the jurisdiction of ASTM Committee D02 on Petroleum Products and Lubricants and is the direct responsibility of Subcommittee D02.04 on Hydrocarbon Analysis.

Current edition approved Nov. 10, 2002. Published February 2003.

<sup>2</sup> *Annual Book of ASTM Standards*, Vol 05.02.

D 5599 Test Method for Determination of Oxygenates in Gasoline by Gas Chromatography and Oxygen Selective Flame Ionization Detection<sup>3</sup>

## 3. Terminology

### 3.1 Definitions:

3.1.1 *oxygenate, n*—an oxygen-containing organic compound, which may be used as a fuel or fuel supplement, for example, various alcohols and ethers.

### 3.2 Definitions of Terms Specific to This Standard:

3.2.1 *hydrogenation, n*—the process of adding hydrogen to olefin molecules as a result of a catalytic reaction.

3.2.1.1 *Discussion*—Hydrogenation is accomplished when olefins in the sample contact platinum at a temperature of 180°C in the presence of hydrogen. The olefins are converted into hydrogen saturated compounds of the same carbon number and structure. Monoolefins and diolefins convert to paraffins while cycloolefins and cycloienes convert to cycloparaffins.

3.2.2 *trap, n*—a device utilized to selectively retain specific portions (individual or groups of hydrocarbons or oxygenates) of the test sample and to release the retained components by changing the trap temperature.

### 3.3 Acronyms:

3.3.1 *ETBE*—ethyl-*tert*-butylether

3.3.2 *MTBE*—methyl-*tert*-butylether

3.3.3 *TAME*—*tert*-amyl-methylether

## 4. Summary of Test Method

4.1 A representative sample is introduced into a computer controlled gas chromatographic system<sup>4</sup> consisting of switching valves, columns, and an olefin hydrogenation catalyst, all operating at various temperatures. The valves are actuated at predetermined times to direct portions of the sample to appropriate columns and traps. As the analysis proceeds, the

<sup>3</sup> *Annual Book of ASTM Standards*, Vol 05.03.

<sup>4</sup> The sole source of supply of the AC Reformulyzer known to the committee at this time is AC Analytical Controls, Inc., 3494 Progress Dr., Bensalem, PA 19020. If you are aware of alternative suppliers, please provide this information to ASTM International Headquarters. Your comments will receive careful consideration at a meeting of the responsible technical committee,<sup>1</sup> which you may attend.

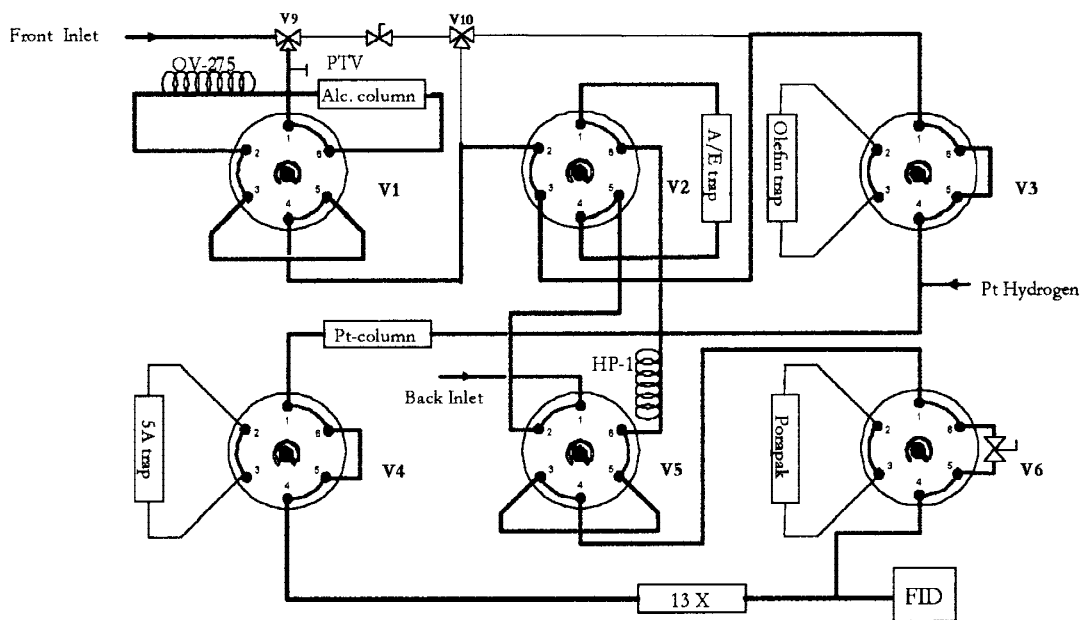

FIG. 1 Typical Instrument Configuration

columns separate these sample portions sequentially into groups of different hydrocarbon types that elute to a flame ionization detector.

4.2 The mass concentration of each detected compound or hydrocarbon group is determined by the application of response factors to the areas of the detected peaks followed by normalization to 100 %. For samples containing methanol or other oxygenates that cannot be determined by this test method, the hydrocarbon results are normalized to 100 % minus the value of the oxygenates as determined by another test method such as Test Method D 4815 or D 5599.

4.3 The liquid volume concentration of each detected compound or hydrocarbon group is determined by application of density factors to the calculated mass concentration of the detected peaks followed by normalization to 100 %.

## 5. Significance and Use

5.1 A knowledge of spark-ignition engine fuel composition is useful for regulatory compliance, process control, and quality assurance.

5.2 The quantitative determination of olefins and other hydrocarbon types in spark-ignition engine fuels is required to comply with government regulations.

5.3 This test method is not applicable to M85 and E85 fuels, which contain 85 % methanol and ethanol, respectively.

## 6. Interferences

6.1 Some types of sulfur-containing compounds are irreversibly adsorbed in the olefin trap reducing its capacity to retain olefins. Sulfur containing compounds are also adsorbed in the alcohol and ether-alcohol-aromatic (EAA) traps. However, a variety of spark-ignition engine fuels have been analyzed without significant performance deterioration of these traps.

6.2 Commercial dyes used to distinguish between grades and types of spark-ignition engine fuels have been found not to interfere with this test method.

6.3 Commercial detergent additives utilized in spark-ignition engine fuels have been found not to interfere with this test method.

6.4 Dissolved water in spark-ignition engine fuels has been found not to interfere with this test method.

## 7. Apparatus

7.1 The complete system that was used to obtain the precision data shown in Section 14 is comprised of a computer controlled gas chromatograph, automated sample injector, and specific hardware modifications. These modifications include columns, traps, a hydrogenator, and valves, which are described in 7.7, 7.8, and in Section 8. Fig. 1 illustrates a typical instrument configuration (see Note 5). Other configurations, components, or conditions may be utilized provided they are capable of achieving the required component separations and produce a precision that is equivalent to, or better than, that shown in the precision tables.

7.2 *Gas Chromatograph*, capable of temperature programmed operation at specified temperatures, equipped with a heated flash vaporization inlet that can be packed (packed column inlet), a flame ionization detector, necessary flow controllers, and computer control.

7.3 *Sample Introduction System*, automatic liquid sampler, capable of injecting a 0.1  $\mu\text{L}$  volume of liquid. The total injected sample shall be introduced to the chromatographic system thus excluding the use of split injections or carrier gas purging of the inlet septum. An auto injector is recommended but optional.

7.4 *Gas Flow and Pressure Controllers*, with adequate precision to provide reproducible flow and pressure of helium to the chromatographic system, hydrogen for the hydrogenator, and hydrogen and air for the flame ionization detector. Control of air flow for cooling specific system components and for automated valve operation is also required.

**TABLE 1 Temperature Control Ranges of System Components**

Component	Typical Operating Temperature Range, °C	Maximum Heating Time, min	Maximum Cooling Time, min
Alcohol trap	60–280	2	5
Polar column	130	isothermal	
Non-polar column	130	isothermal	
Olefin trap	120–280	1	5
Molsieve 13X column	90–430	Temperature programmed, ~10°/min	
Porapak column	130–140	isothermal	
Ether-alcohol-aromatic (EAA) trap	70–280	1	5
Hydrogenation catalyst	180	isothermal	
Column switching valves	130	isothermal	
Sample lines	130	isothermal	

7.5 *Electronic Data Acquisition System*, shall meet or exceed the following specifications (see Note 2):

7.5.1 Capacity for 150 peaks for each analysis.

7.5.2 Normalized area percent calculation with response factors.

7.5.2.1 Area summation of peaks that are split or of groups of components that elute at specific retention times.

7.5.3 Noise and spike rejection capability.

7.5.4 Sampling rate for fast (<0.5 s) peaks (>20 Hz to give 10 points across peak).

7.5.5 Peak width detection for narrow and broad peaks.

7.5.6 Perpendicular drop and tangent skimming, as required.

NOTE 2—Standard supplied software is typically satisfactory.

7.6 *Temperature Controllers of System Components*—The independent temperature control of numerous columns and traps, the hydrogenation catalyst, column switching valves, and sample lines is required. All of the system components that contact the sample shall be heated to a temperature that will prevent condensation of any sample component. Table 1 lists the system components and operating temperatures (see Note 3). Some of the components require isothermal operation, some require rapid heating and cooling, while one requires reproducible temperature programming. The indicated temperatures are typical; however, the control systems utilized shall have the capability of operating at temperatures  $\pm 20^\circ\text{C}$  of those indicated to accommodate specific systems. Temperature control may be by any means that will meet the requirements listed in Table 1.

NOTE 3—The system components and temperatures listed in Table 1 and Section 8 are specific to the analyzer used to obtain the precision data shown in Section 14. Other columns and traps that can adequately perform the required separations are also satisfactory but may require different temperatures.

7.7 *Valves, Column and Trap Switching*—Automated, rotary valves are recommended. The valves shall be intended for gas chromatographic usage and meet the following requirements:

7.7.1 The valves must be capable of continuous operation at operating temperatures that will prevent sample condensation.

7.7.2 The valves shall be constructed of materials that are nonreactive with the sample under analysis conditions. Stainless steel, PFA,<sup>5</sup> and Vespel<sup>5</sup> are satisfactory.

7.7.3 The valves shall have a small internal volume but offer little restriction to carrier gas flow under analysis conditions.

7.8 *Valves, Air*—to control pressurized air for column and trap cooling. Automated valves are recommended.

NOTE 4—New valves, tubing, catalyst, columns, traps, and other materials that contact the sample or gasses may require conditioning prior to operation in accordance with the manufacturer's recommendations.

7.9 *Gas Purifiers*, to remove moisture and oxygen from helium, moisture and hydrocarbons from hydrogen, and moisture and hydrocarbons from air.

## 8. Reagents and Materials

8.1 *Air*, compressed, <10 mg/kg each of total hydrocarbons and H<sub>2</sub>O. (**Warning**—Compressed gas under high pressure that supports combustion.)

8.2 *Helium*, 99.999 % pure, <0.1 mg/kg H<sub>2</sub>O. (**Warning**—Compressed gas under high pressure.)

8.3 *Hydrogen*, 99.999 % pure, <0.1 mg/kg H<sub>2</sub>O. (**Warning**—Extremely flammable gas under high pressure.)

8.4 *Columns, Traps, and Hydrogenation Catalyst (System Components)*—This test method requires the use of four columns, two traps, and a hydrogenation catalyst (see Note 3). Each system component is independently temperature controlled as described in 7.6 and Table 1. Refer to Fig. 1 for the location of the components in the system (see Note 5). The following list of components contains guidelines that are to be used to judge suitability. The guidelines describe temperatures and times as used in the current system. Alternatives can be used provided that the separation as described is obtained and the separation characteristics of the entire system are not limited.

NOTE 5—Fig. 1 shows an additional trap, Molsieve 5A, and rotary valve V4 that are not required for this test method. They are included in Fig. 1 because they were present in the instrumentation used to generate the precision data. They can be used for more detailed analyses outside the scope of this test method, where an iso-normal paraffin, iso-normal olefin determination is desired. There is no statistical data included in this test method relating to their use.

8.4.1 *Alcohol Trap*—Within a temperature range from 140 to 160°C, this trap must elute benzene, toluene, all paraffins, olefins, naphthenes, and ethers within the first 2 min after sample injection while retaining C<sub>8</sub>+ aromatics, all alcohols, and any other sample components.

8.4.1.1 At a temperature of 280°C, all retained components from 8.4.1 shall elute within 2 min of when the trap is backflushed.

8.4.2 *Polar Column*—At a temperature of 130°C, this column must retain all aromatic components in the sample longer than the time required to elute all non-aromatic components boiling below 185°C, within the first 5 min after sample injection.

<sup>5</sup> PFA and Vespel are trademarks of E. I. DuPont de Nemours and Co.

8.4.2.1 The column shall elute benzene, toluene, and all non-aromatic components with a boiling point below 215°C within 10 min of the introduction of these compounds into the column.

8.4.2.2 This column shall elute all retained aromatic components from 8.4.2 within 10 min of when this column is backflushed.

8.4.3 *Non-Polar Column*—At a temperature of 130°C, this column shall elute and separate aromatics by carbon number boiling below 200°C. Higher boiling paraffins, naphthenes, and aromatics are backflushed.

8.4.4 *Olefin Trap*—Within a temperature range from 90 to 105°C, this trap shall retain (trap) all olefins in the sample for at least 6.5 min and elute all non-olefinic components up to C<sub>7</sub> in less than 6.5 min after the sample is injected. Non-olefinic components C<sub>9</sub> and higher shall be retained during this time.

8.4.4.1 Within a temperature range from 140 to 150°C this trap shall retain C<sub>6</sub> and higher olefins and elute all non-olefinic components in 3 min. Olefins up to C<sub>6</sub> may or may not elute in this time.

8.4.4.2 At a temperature of 280°C, this trap shall quantitatively elute all retained olefins.

8.4.5 *Molsieve 13X Column*—This column shall separate paraffin and naphthene hydrocarbons by carbon number when temperature programmed from 90 to 430°C at approximately 10°/min.

8.4.6 *Porapak Column*—At a temperature from 130 to 140°C, this column shall separate individual oxygenates, benzene, and toluene.

8.4.7 *Ether-Alcohol-Aromatic (EAA) Trap*—Within a temperature range from 105 to 130°C, this trap shall retain all of the ethers in the sample and elute all non-aromatic hydrocarbons boiling below 175°C within the first 6 min after sample injection.

8.4.7.1 At a temperature of 280°C, this trap shall elute all retained components.

8.4.8 *Hydrogenation Catalyst*, platinum. At a temperature of 180°C and an auxiliary hydrogen flow of 14 ± 2 mL/min, this catalyst shall quantitatively hydrogenate all olefins to paraffinic compounds of the same structure without cracking.

8.5 *Test Mixture*—A quantitative synthetic mixture of pure hydrocarbons is required to verify that all instrument components, temperatures, and cut times are satisfactory to produce accurate analyses and to aid in making operating adjustments as columns and traps age. The mixture may be purchased or prepared according to Practice D 4307. Each component used in the test mixture preparations shall have a minimum purity of 99 %. The actual concentration levels are not critical but shall be accurately known.

8.5.1 *System Validation Test Mixture*, used to monitor and make adjustments to the total operation of the system. The composition and approximate component concentrations are shown in Table 2.

8.6 *Quality Control Sample*, used to routinely monitor the operation of the chromatographic system and verify that reported concentrations are within the precision of the test method. Depending on the range and composition of the samples to be analyzed, more than one quality control sample

**TABLE 2 System Validation Test Mixture**

Component	Approximate Concentration Mass, %	Warning
Cyclopentane	1.1	A
Pentane	1.1	A
Cyclohexane	2.1	A
2,3-Dimethylbutane	2.1	A
Hexane	2.1	A
1-Hexene	1.5	A
Methylcyclohexane	4.0	A
4-Methyl-1-hexene	1.6	A
Heptane	3.5	B
1-cis-2-Dimethylcyclohexane	5.0	A
2,2,4-Trimethylpentane	5.0	B
Octane	5.0	B
1-cis-2-cis-4-Trimethylcyclohexane	4.0	B
Nonane	4.5	B
Decane	4.5	B
Undecane	3.5	B
Dodecane	3.5	B
Benzene	2.2	B
Methylbenzene (Toluene)	2.2	B
trans-Decahydronaphthalene (Decalin)	4.0	B
Tetradecane	4.5	B
Ethylbenzene	4.5	A
1,2-Dimethylbenzene (o-Xylene)	4.0	A
Propylbenzene	5.0	A
1,2,4-Trimethylbenzene	4.5	A
1,2,3-Trimethylbenzene	5.0	A
1,2,4,5-Tetramethylbenzene	5.0	B
Pentamethylbenzene	5.0	C
Group Totals		
Paraffins	34.8	
Olefins	3.1	
Naphthenes	20.2 (including Decalin)	
Aromatics	41.9	
Oxygenates	0.0	
TOTAL	100.0	

<sup>A</sup> (Warning—Extremely flammable. Harmful if inhaled.)

<sup>B</sup> (Warning—Flammable. Harmful if inhaled.)

<sup>C</sup> (Warning—Harmful if inhaled.)

may be necessary. Any sample that is similar in composition to samples typically analyzed may be designated as the quality control (QC) sample. The QC sample shall be of sufficient volume to provide an ample supply for the intended period of use and it shall be homogeneous and stable under the anticipated storage conditions.

8.6.1 The quality control sample should have similar composition and hydrocarbon distribution as the sample with highest olefin concentration routinely analyzed.

8.6.2 The quality control sample should contain oxygenates as analyzed in routine samples. Separate standards could be used for different oxygenates.

8.6.2.1 In the event that samples containing TAME or ethanol need to be analyzed, it is best to use separate standards since optimal separation of these components requires different alcohol trap temperature conditions.

## 9. Preparation of Apparatus

9.1 Assemble the analyzer system (gas chromatograph with independent temperature controlled components) as shown in Fig. 1 or with an equivalent flow system. If using a commercial system, install and place the system in service in accordance with the manufacturer's instructions.