



Designation: F 2012 – 03

Standard Consumer Safety Performance Specification for Stationary Activity Centers¹

This standard is issued under the fixed designation F 2012; the number immediately following the designation indicates the year of original adoption or, in the case of revision, the year of last revision. A number in parentheses indicates the year of last approval. A superscript epsilon (ϵ) indicates an editorial change since the last revision or reapproval.

INTRODUCTION

This consumer safety performance specification is intended to mitigate potential safety hazards associated with a child's use of a stationary activity center and thereby minimize the risk of injury or death. The specific hazards addressed by this specification are seat strength to support the occupant, product tip over, openings for finger entrapment and small parts.

1. Scope

1.1 This consumer safety performance specification covers performance requirements, test methods and marking requirements to promote safe use of a stationary activity center by an occupant.

1.2 This consumer safety performance specification is intended to minimize the risk of incidents to an occupant resulting from normal use and reasonably foreseeable misuse or abuse of a stationary activity center.

1.3 No stationary activity center produced after the approval date of this consumer safety performance specification shall, either by label or other means, indicate compliance with this specification unless it conforms to all requirements contained herein.

1.4 This consumer safety performance specification is not intended to address incidents and injuries resulting from the interaction of other persons with the child occupant in the stationary activity center or the incidents resulting from abuse and misuse by children able to walk.

1.5 The test values in inch-pound units stated in this Consumer Safety Specification are to be regarded as the standard. The metric values in parentheses are given for information only.

1.6 The following precautionary caveat pertains only to the test method portion, Section 7, of this consumer safety performance specification: *This standard does not purport to address all of the safety concerns, if any, associated with its use. It is the responsibility of the user of this standard to establish*

appropriate safety and health practices and determine the applicability of regulatory limitations prior to use.

2. Referenced Documents

2.1 *ASTM Standards:*²

D 3359 Test Methods for Measuring Adhesion by Tape Test

F 963 Consumer Safety Specification for Toy Safety

2.2 *Federal Regulations:*

16 CFR 1303 Ban of Lead-Containing Paint and Certain Consumer Products Bearing Lead-Containing Paint³

16 CFR 1500 Hazardous Substances Act Regulations including sections:³

1500.18(a)(6) Banned Toys and Other Banned Articles Intended for Use by Children

1500.48 Technical Requirements for Determining a Sharp Point in Toys or Other Articles Intended for Use by Children Under Eight Years of Age

1500.49 Technical Requirements for Determining a Sharp Metal or Glass Edge in Toys or Other Articles Intended for Use by Children Under Eight Years of Age

1500.50-.52 Test Methods for Simulating Use and Abuse of Toys and Other Articles Intended for Use by Children

15.00.86(a)(4) Exemptions from Classification as a Banned Article for Use by Children

16 CFR 1501 Method for Identifying Toys and Other Articles Intended for Use by Children Under Three Years of Age Which Present Choking, Aspiration or Ingestion Hazards Because of Small Parts³

2.3 *Other References:*

¹ This consumer safety performance specification is under the jurisdiction of ASTM Committee F15 on Consumer Products and is the direct responsibility of Subcommittee F15.17 on Carriages, Strollers, Walkers, and Stationary Activity Centers.

Current edition approved Aug. 10, 2003. Published September 2003. Originally approved in 2000. Last previous edition approved in 2000 as F 2012 – 00a.

² For referenced ASTM standards, visit the ASTM website, www.astm.org, or contact ASTM Customer Service at service@astm.org. For *Annual Book of ASTM Standards* volume information, refer to the standard's Document Summary page on the ASTM website.

³ Available from Superintendent of Documents, US Government Printing Office, Washington, DC 20402.



FIG. 1 CAMI Infant Dummy—Mark II

CAMI Infant Dummy, Mark II (see Fig. 1)⁴

3. Terminology

3.1 Definitions of Terms Specific to This Standard:

3.1.1 *conspicuous, adj*—a label that is visible, when the activity center is in a manufacturer’s recommended use position, to a person standing near the activity center at any one position around the activity center but not necessarily visible from all positions.

3.1.2 *dynamic load, n*—application of an impulsive force through free fall of a weight.

3.1.3 *manufacturer’s recommended use position(s), n*—any position that is presented as a normal, allowable or acceptable configuration for the use of the product by the manufacturer in any descriptive or instructional literature. This specifically excludes positions that the manufacturer shows in a like manner in its literature to be unacceptable, unsafe or not recommended.

3.1.4 *non-paper label, n*—any label material (such as plastic or metal) which either will not tear without the aid of tools or tears leaving a sharply defined edge.

3.1.5 *occupant, n*—that individual who is in a product that is set up in one of the manufacturer’s recommended use positions.

3.1.6 *open base stationary activity center, n*—a stationary activity center that allows the occupant’s feet to contact the floor.

3.1.7 *paper label, n*—any label material which tears without the aid of tools and leaves a fibrous edge.

3.1.8 *static load, n*—a vertically downward force applied by a calibrated force gage or by dead weights.

3.1.9 *stationary activity center, n*—a freestanding product intended to remain stationary that enables a sitting or standing occupant whose torso is completely surrounded by the product to walk, rock, play, spin or bounce, or all of these, within a limited range of motion.

4. Calibration and Standardization

4.1 All testing shall be conducted on a concrete floor that may be covered with 1/8 in. (3 mm) thick vinyl flooring, unless test instructs differently.

4.2 The product shall be completely assembled, unless otherwise noted, in accordance with the manufacturer’s instructions.

4.3 No testing shall be conducted within 48 h of manufacturing.

4.4 The product to be tested shall be in a room with an ambient temperature of 73 ± 9°F (23 ± 5°C) for at least 1 h prior to testing. Testing shall then be conducted within this temperature range.

4.5 All testing required by this specification shall be conducted on the same unit.

5. General Requirements

5.1 *Hazardous Sharp Edges or Points*—There shall be no hazardous sharp edges or points as defined by 16 CFR 1500.48 and 16 CFR 1500.49 before and after testing to this consumer safety specification.

5.2 *Small Parts*—There shall be no small parts as defined by 16 CFR 1501 before testing or liberated as a result of testing to this specification

5.3 *Wood Parts*—Prior to testing, any exposed wood parts shall be smooth and free of splinters.

5.4 *Latching or Locking Mechanisms*—Any product that folds shall have a latching or locking device or other provision in the design that will prevent the unit from unintentionally folding when properly placed in the manufacturer’s recommended use position. The unit shall remain in its manufacturer’s recommended use position during and upon completion of the test in accordance with 7.2. If a unit is designed with a latching or locking device, that device shall remain engaged and operative after testing.

5.5 *Openings*—Holes or slots that extend entirely through a wall section of any rigid material less than 0.375 in. (9.53 mm) thick and admit a 0.210-in. (5.33-mm) diameter rod shall also admit a 0.375-in. (9.53-mm) diameter rod. Holes or slots that are between 0.210 in. (5.33 mm) and 0.375 in. (9.53 mm) and have a wall thickness less than 0.375 in. (9.53 mm), but are limited in depth to 0.375 in. (9.53 mm) maximum by another rigid surface shall be permissible (see Fig. 2). The product shall be evaluated in all manufacturer’s recommended use positions.

5.6 *Scissoring, Shearing, Pinching*—A product, when in a manufacturer’s recommended use position, shall be designed and constructed so as to prevent injury to the occupant from any scissoring, shearing or pinching when members or components rotate about a common axis or fastening point, slide, pivot, fold or otherwise move relative to one another. Scissoring, shearing or pinching that may cause injury shall not be permissible when the edges of the rigid parts admit a probe

⁴ Department of Transportation Memorandum Report AAC-119-74-14, Revision II, Drawing No. SA-1001 by Richard Chandler, July 2, 1974. Federal Aviation Administration, Civil Aeromedical Institute, Protection and Survival Laboratory, Aeronautical Center, Oklahoma City, OK 73125.

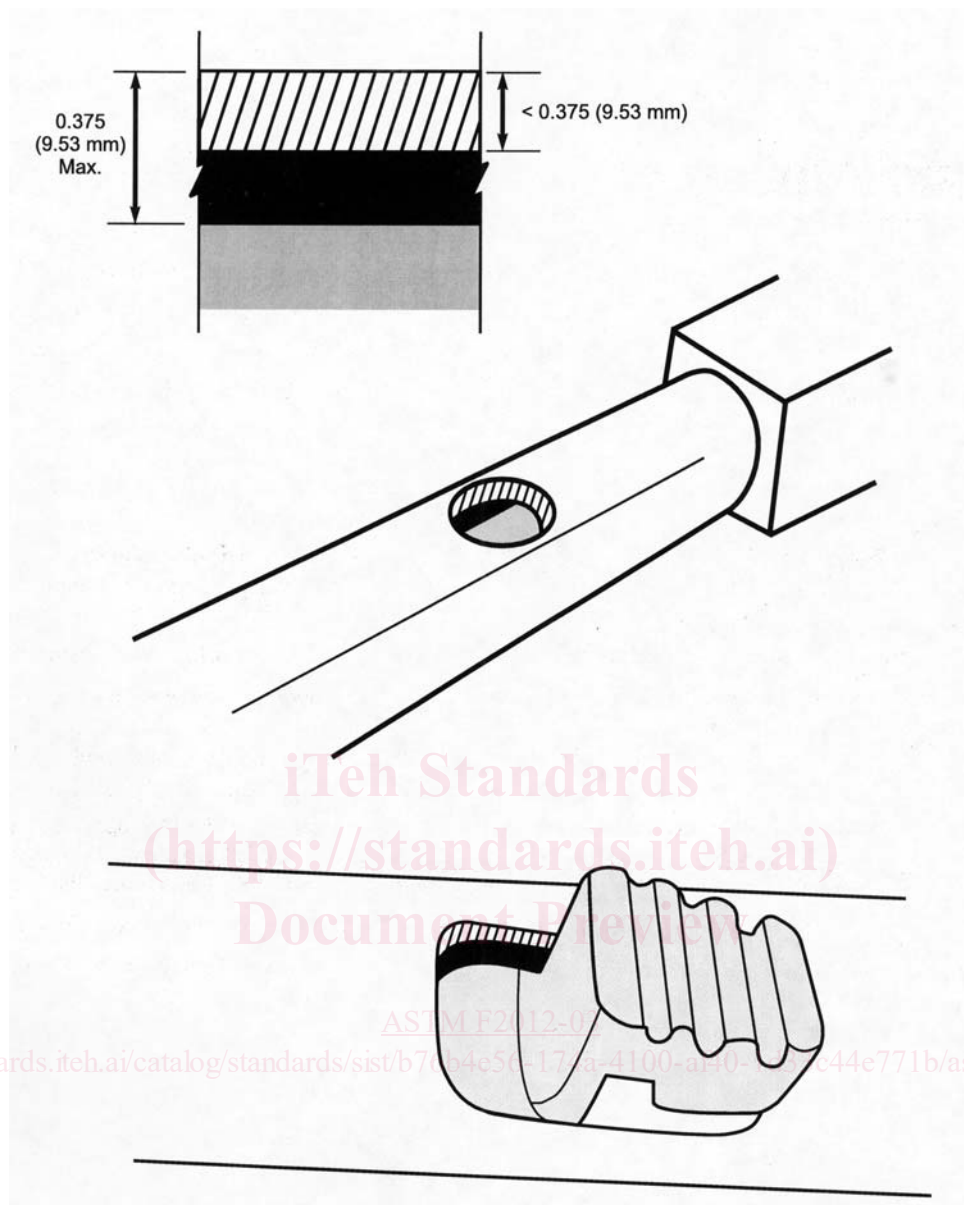

FIG. 2 Opening Example

greater than 0.210 in. (5.33 mm) and less than 0.375 in. (9.53 mm) diameter at any accessible point throughout the range of motion of such parts.

5.7 *Exposed Coil Springs*—Any exposed coil spring which is accessible to the occupant, having or capable of generating a space between coils of 0.210 in. (5.33 mm) or greater during static load testing in accordance with 7.1.2 shall be covered or otherwise designed to prevent injury from entrapment.

5.8 *Labeling:*

5.8.1 Warning labels (whether paper or non-paper) shall be permanent when tested in accordance with 7.5.1-7.5.3.

5.8.2 Warning statements applied directly onto the surface of the product by hot stamping, heat transfer, printing, wood burning, etc. shall be permanent when tested in accordance with 7.5.4.

5.8.3 Nonpaper labels shall not liberate small parts when tested in accordance with 7.5.5.

5.9 *Toys*—Toy accessories attached to, removable from, or sold with a stationary activity center, as well as their means of attachment, must meet applicable requirements of Specification F 963.

5.10 *Protective Components*—If a child can grasp components between the thumb and forefinger, or teeth (such as caps, sleeves, or plugs used for protection from sharp edges, points, or entrapment of fingers or toes), or if there is at least a 0.040 in. (1.00 mm) gap between the component and its adjacent parent component, such component shall not be removed when tested in accordance with 7.4.4.

6. Performance Requirements

NOTE 1—The forces which are to be applied to the sample in the tests described in Section 7 of this standard are readily applied by means of a calibrated force gage, or in the case of static load and dynamic load tests, by dead weights.