**Information technology — Open Distributed
Management Architecture**

**AMENDMENT 1: Support using Common
Object Request Broker Architecture (CORBA)**

*Technologies de l'information — Architecture de gestion répartie ouverte
(ODMA)*

*AMENDEMENT 1: Support utilisant une architecture de courtier de
demande d'objet courant (CORBA)*

[ISO/IEC 13244:1998/Amd 1:1999](https://standards.iso.org/iso-iec/13244-1998-amd-1-1999)

<https://standards.iteh.ai/catalog/standards/sist/132ace7f-0a11-4acb-b349-97defcb9e24f/iso-iec-13244-1998-amd-1-1999>



iTeh STANDARD PREVIEW
(standards.iteh.ai)

[ISO/IEC 13244:1998/Amd 1:1999](https://standards.iteh.ai/catalog/standards/sist/132ace7f-0a11-4acb-b349-97defcb9e24f/iso-iec-13244-1998-amd-1-1999)

<https://standards.iteh.ai/catalog/standards/sist/132ace7f-0a11-4acb-b349-97defcb9e24f/iso-iec-13244-1998-amd-1-1999>

© ISO/IEC 1999

All rights reserved. Unless otherwise specified, no part of this publication may be reproduced or utilized in any form or by any means, electronic or mechanical, including photocopying and microfilm, without permission in writing from the publisher.

ISO/IEC Copyright Office • Case postale 56 • CH-1211 Genève 20 • Switzerland

Printed in Switzerland

Contents

	<i>Page</i>
1) Clause 1	1
2) Clause 2	1
3) New subclause 2.3	1
4) Clause 4	2
5) New clause 8.....	2
6) New Annexes G and H	6

iTeh STANDARD PREVIEW
(standards.iteh.ai)

[ISO/IEC 13244:1998/Amd 1:1999](https://standards.iteh.ai/catalog/standards/sist/132ace7f-0a11-4acb-b349-97defcb9e24f/iso-iec-13244-1998-amd-1-1999)

<https://standards.iteh.ai/catalog/standards/sist/132ace7f-0a11-4acb-b349-97defcb9e24f/iso-iec-13244-1998-amd-1-1999>

Foreword

ISO (the International Organization for Standardization) and IEC (the International Electrotechnical Commission) form the specialized system for worldwide standardization. National bodies that are members of ISO or IEC participate in the development of International Standards through technical committees established by the respective organization to deal with particular fields of technical activity. ISO and IEC technical committees collaborate in fields of mutual interest. Other international organizations, governmental and non-governmental, in liaison with ISO and IEC, also take part in the work.

In the field of information technology, ISO and IEC have established a joint technical committee, ISO/IEC JTC 1. Draft International Standards adopted by the joint technical committee are circulated to national bodies for voting. Publication as an International Standard requires approval by at least 75 % of the national bodies casting a vote.

Amendment 1 to ISO/IEC 13244:1998 was prepared by Joint Technical Committee ISO/IEC JTC 1, *Information technology*, Subcommittee SC 33, *Distributed application services*, in collaboration with ITU-T. The identical text is published as ITU-T Rec. X.703/Amd.1.

iTeh STANDARD PREVIEW (standards.iteh.ai)

[ISO/IEC 13244:1998/Amd 1:1999](https://standards.iteh.ai/catalog/standards/sist/132ace7f-0a11-4acb-b349-97defcb9e24f/iso-iec-13244-1998-amd-1-1999)

<https://standards.iteh.ai/catalog/standards/sist/132ace7f-0a11-4acb-b349-97defcb9e24f/iso-iec-13244-1998-amd-1-1999>

INTERNATIONAL STANDARD

ITU-T RECOMMENDATION

INFORMATION TECHNOLOGY– OPEN DISTRIBUTED MANAGEMENT ARCHITECTURE

AMENDMENT 1

Support using Common Object Request Broker Architecture (CORBA)

1) Clause 1

Update the scope clause to change potential amendment to amendment (in Figure 1).

iTeh STANDARD PREVIEW
(standards.iteh.ai)

2) Clause 2

[ISO/IEC 13244:1998/Amd 1:1999](https://standards.iteh.ai/catalog/standards/sist/132ace7f-0a11-4acb-b349-13244-1998/Amd.1-1999)

[https://standards.iteh.ai/catalog/standards/sist/132ace7f-0a11-4acb-b349-](https://standards.iteh.ai/catalog/standards/sist/132ace7f-0a11-4acb-b349-13244-1998/Amd.1-1999)

Add a reference by alphabetical order to the ODMA Notification Selection and Dispatch Function:

- ITU-T Recommendation X.770 (199x) | ISO/IEC 15427-1:199x, *Information technology – Open Distributed Management Architecture – Notification Selection and Dispatch Function*

3) New subclause 2.3

Add a new subclause for PAS references:

2.3 Publicly available specification references

All references in this subclause were correct at the time of approval of this Recommendation | International Standard. The provisions of the references specifications, as identified in this subclause, are valid within the context of this Recommendation | International Standard. The reference to a specification within this Recommendation | International Standard does not give it any further status within ITU-T or ISO/IEC; in particular, it does not give the referenced specification the status of a Recommendation | International Standard.

Temporary Note – A reference explanatory report is circulated with the DAM ballot on this specification.

- CORBA: *The Common Object Request Broker: Architecture and Specification*, Revision 2.1, Object Management Group, August 1997 (OMG Doc Number: Formal/97-09-01).
- CORBA Services: *Common Object Services Specification*, Object Management Group, November 1997 (OMG Doc Number: Formal/97-12-02).
- CORBA Facilities: *Common Object Facilities Specification*, Object Management Group, Revision 4, November 1995 (OMG Doc Number: Formal/97-06-15).

4) Clause 4

Add the following abbreviations by alphabetical order:

bmos	base management-operation server
DII	Dynamic Invocation Interface
GIOP	General Inter Orb Protocol
IR	Interface Repository
JIDM	X/Open – NMF Joint Inter-Domain Management
OMG	Object Management Group
ORB	Object Request Broker
SNMP	Simple Network Management Protocol

5) New clause 8

Add the following clause amendment text:

8 CORBA support for ODMA

Mechanisms to realize ODMA systems are not unique, and there may be multiple approaches. OSI Systems Management, as described in clause 7, is one approach. This clause describes another approach, using OMG CORBA.

The OMG CORBA a distributed processing infrastructure. This clause describes how CORBA can be used to support ODMA.

NOTE – OMG is a consortium recognized internationally as a major contributor to information technology. ODP IDL, as defined in ITU-T Rec. X.920 | ISO/IEC 14750, is technically aligned with the OMG IDL defined in CORBA.

It is envisaged that CORBA-based technology has the potential to progress development in the following areas:

- CORBA isolates the engineer from the Operating System and language dependencies.
- The development of management systems can internally make substantial use of implementations of the currently defined CORBA Services and CORBA Facilities.
- Facilitating interoperability between management systems. CORBA is a standard middleware component supporting programming language independent interface definition, standard language mappings, and has multi-vendor support. The publication of interfaces to application functions supported by management systems in ODP IDL should facilitate interworking between such management systems.
- CORBA-based infrastructure may facilitate the development of purely CORBA-based management systems with standard "off the shelf" components.

It is intended (where appropriate) to reuse the knowledge and specifications generated as a result of activities within traditional OSI Systems Management. There is also a general realisation that many of the advantages offered by distributed object computing in general, and specifically by CORBA, will enhance the features of systems developed in this context.

The enterprise and information viewpoint descriptions of CORBA support for ODMA are the same as the corresponding enterprise and information viewpoint in clause 6, General framework.

8.1 Computational viewpoint

The functions introduced by the ODMA should complement the more general CORBA services and CORBA facilities. The complete set of service specifications will be fundamental to providing a framework for developing distributed telecommunications management applications.

8.1.1 CORBA managed objects

In this subclause, the term "**CORBA managed object**" is used to refer to a managed role computational object which is realized in a CORBA environment.

There is a need to define a commonly agreed base management-operation server (bmos) interface type, which CORBA managed objects should support. The widespread support of this bmos interface type by CORBA managed objects will provide commonality between the various groups defining services for CORBA-based open distributed management.

NOTE – The term base interface is used to imply that other interface types may be derived from it using inheritance, or other forms of subtyping.

Each CORBA managed object has at least one interface, defined in ODP IDL, for the attributes and operations which it supports. A bmos interface type in this context would include all of the basic common features associated with any CORBA managed object. This could include information about the interface types supported by the CORBA managed object, the identifier for a CORBA managed object instance. This bmos interface type could then be specialized for each type of CORBA managed object in the system.

ODP IDL offers facilities to define interfaces. The same interface definition is used by both the client and the server.

It is equally important to design distributed managed systems so that new CORBA managed object types (with corresponding new interface types) may be installed in the system during run time, without rebuilding the system software to work with the new definitions. The Dynamic Skeleton Interface is a mechanism which may be used to build such flexible systems, but other mechanisms may also be employed.

When a bmos interface type is used for a CORBA managed object, a limited set of management operations can be invoked by the managing system without knowledge of the specific features of a specialized CORBA managed object type.

8.1.2 Handling of notifications

ODMA notifications are treated as operation invocations from managed entities onto an event distribution mechanism [which is based on the extension of the CORBA event service (CORBA Services)]. Each defined ODMA notification results in the specification of sets of operations in notification server interfaces. These notification server interfaces may be supported by notification dispatcher binding objects (e.g. CORBA event channel) or destination objects.

The handling of ODMA notifications, in the CORBA environment [as defined in the CORBA Event Service specification (CORBA Services)], may be accomplished using either CORBA typed or untyped events, and using either the push or pull models for delivery of event reports.

In the CORBA Event Service:

- the push model implies that the sender of an event report invokes an operation on the receiving object (with the event report contents contained in the invocation); while,
- the pull model implies that the receiver of an event report invokes an operation on the sending object (with the event report contents in the termination message).

The ODMA definition of notification, and all the figures in this Specification, assume that the push model is being used for notification delivery. In the case of the pull model, the notification client and notification server roles are reversed, but this is not explicitly shown in this Recommendation | International Standard.

There is a need for a CORBA-based event distribution mechanism (such as that provided by ITU-T Rec. X.770 | ISO/IEC 15427-1) which allows notifications emitted from a single CORBA managed object to be delivered to multiple destination computational objects which subscribe to particular types of notifications.

The definition of ODMA notification, which is intended to allow distribution to multiple destinations, does not allow any information, other than acknowledgement of receipt, to be returned in the reply to the notification delivery operation in the push model (either from the CORBA managed object to the event distribution object, or from the event distribution object to the destination).

NOTE – The pull mode of delivery makes acknowledgement of receipt unnecessary from the point of view of the notification receiver.

There is a need for event distribution mechanisms which can be configured for various quality of service levels, including the ability for the event distribution computational object to queue notifications for delivery when the ultimate destination becomes available for delivery.

8.1.3 Handling of linked replies

In CORBA, linked replies are realized by the client of the original operation (i.e. computational object in the managing role) providing an input parameter in the operation signature, which gives a reference to the Irs interface to be used for invoking the linked replies.

NOTE – This is sometimes referred to as a callback.

8.1.4 Handling of scoping

Multiple object access via scoping can be handled either directly by the CORBA managed object (through operations in one of its management-operation server interfaces), or by a scoping mechanism (existing on another object outside of the CORBA managed object) that presents a generic management interface that supports scoping parameters.

8.1.5 Handling of filtering

The handling of filtering can be supported directly by the CORBA managed object (through parameters of operations in its management-operation server interfaces), or through the use of specialized filter objects placed between the managing role computational object and the CORBA managed object.

8.2 Engineering viewpoint

8.2.1 Support for access transparency

In ODMA we are distributing the intelligence of the management applications between the managing and the managed system. A managing system provides management functions by using objects in the managing role, which invoke operations which ultimately affect objects in the managed role, located in managed systems. If a managing system relies on a proper use of CORBA stubs and the Dynamic Invocation Interface (DII) to access services from the managed system, the release of a new version of the managing system each time a modification occurs in the network will not be necessary.

To prevent modifying the managing system each time the managed system introduces new interface types, the managing system should use the CORBA Interface Repository (IR) to investigate the interface definitions and should use the CORBA DII to invoke new or extended services.

8.2.2 Support for location transparency

CORBA supports location transparency, which is provided by the ORB, as shown in Figure 8-1. Figure 8-1 shows:

- a managing role stub for management-operation client, linked reply server, and notification server interfaces;
- a managed role stub for management-operation server, linked reply client, and notification client interfaces; and
- an Object Request Broker which provides this transparency.

This means that the CORBA managed objects can be located in different address spaces (or only one).

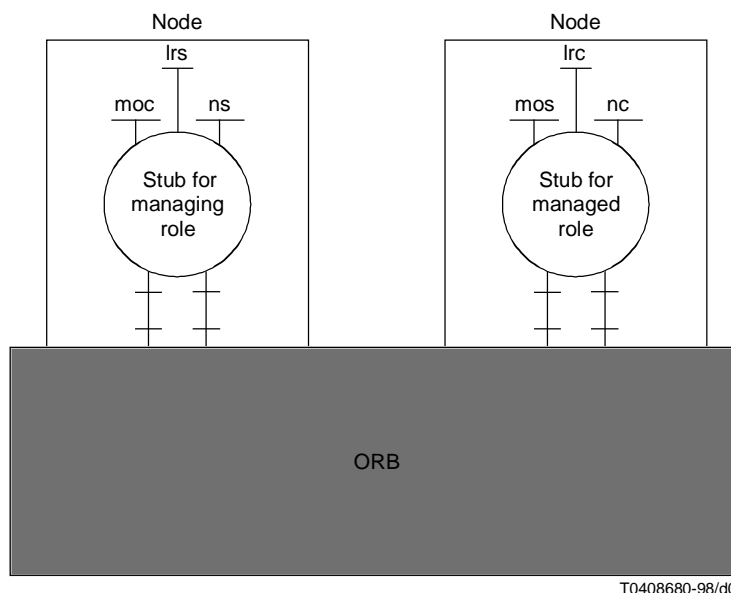

Figure 8-1 – CORBA engineering provided by the ORB

8.2.3 CORBA implementation support

Implementing managing systems can be treated as a specific case of implementing more general information systems.

It is natural for designers of object oriented management systems to expect that modern software development environments (languages, code libraries, databases, GUI, etc.) are to be employed. CORBA is an infrastructure which supports application development in such an environment.

CORBA-based management systems may need to use gateways to interact with systems using other communication paradigms. An informative discussion of approaches for interaction gateways for interworking between different communication infrastructures is presented in Annex H.

8.2.4 CORBA managed objects with heterogeneous agents

This subclause discusses how a CORBA-based managed system may provide various communications interfaces to managing systems.

OSI Systems Management standards specify interfaces between managing systems and managed systems, using an Agent process in the managed system to act on behalf of the managed objects. This is shown in Figure 8-2 as CMIP access to the CORBA-based managed objects and support objects through an OSI agent.

Figure 8-2 shows a CORBA-based managed open system which supports multiple management protocols. Managed objects which are defined using GDMO to be accessed by CMIP can be implemented as CORBA based objects. By doing this, these CORBA-based managed object implementations may also be accessed using CORBA interoperability protocols. Proprietary infrastructure mechanisms may have ways to interwork with CORBA objects, in a similar manner.

iTeh STANDARD PREVIEW
(standards.itih.ai)

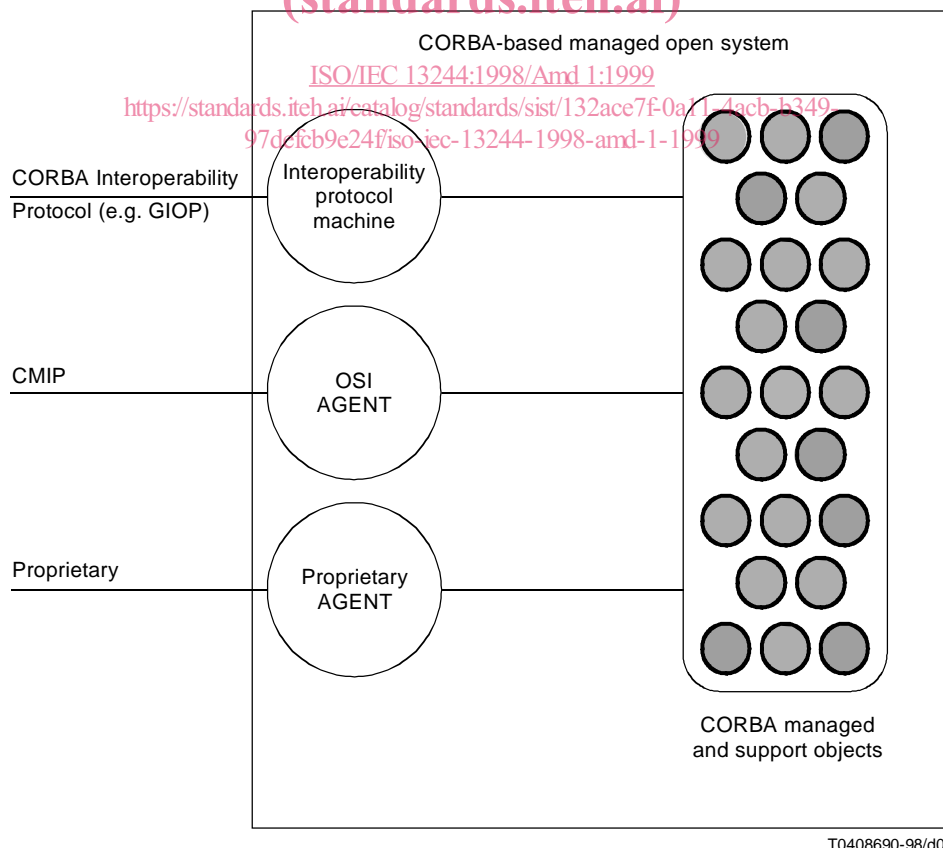

Figure 8-2 – CORBA-based managed open system