



Standard Test Method for Measurement of Extreme-Pressure Properties of Lubricating Fluids (Four-Ball Method)¹

This standard is issued under the fixed designation D 2783; the number immediately following the designation indicates the year of original adoption or, in the case of revision, the year of last revision. A number in parentheses indicates the year of last reapproval. A superscript epsilon (ε) indicates an editorial change since the last revision or reapproval.

1. Scope

1.1 This test method covers the determination of the load-carrying properties of lubricating fluids. The following two determinations are made:

1.1.1 Load-wear index (formerly Mean-Hertz load).

1.1.2 Weld point by means of the four-ball extreme-pressure (EP) tester.

1.2 For the determination of the load-carrying properties of lubricating greases, see Test Method D 2596.

1.3 This standard does not purport to address all of the safety concerns, if any, associated with its use. It is the responsibility of the user of this standard to establish appropriate safety and health practices and determine the applicability of regulatory limitations prior to use.

1.4 The values stated in SI units are to be regarded as the standard. The values given in parentheses are for information only.

2. Referenced Documents

2.1 ASTM Standards:

D 2596 Test Method for Measurement of Extreme-Pressure Properties of Lubricating Grease (Four-Ball Method)²

2.2 ANSI Standard:

B 3.12 Metal Balls³

3. Terminology

3.1 Definitions:

3.1.1 *compensation line*—a line of plot on logarithmic paper, as shown in Fig. 1, where the coordinates are scar diameter in millimetres and applied load in kilograms-force (or newtons), obtained under dynamic conditions.

3.1.1.1 *Discussion*—Coordinates for the compensation line are found in Table 1, Columns 1 and 3.

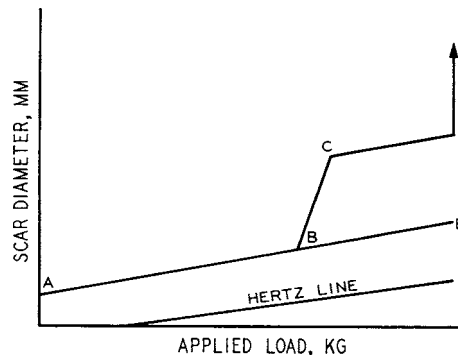

ABE—Compensation line.
B—Point of last nonseizure load.
BC—Region of incipient seizure.
CD—Region of immediate seizure.
D—Weld point.

FIG. 1 Schematic Plot of Scar Diameter Versus Applied Load

3.1.1.2 *Discussion*—Some lubricants give coordinates which are above the compensation line. Known examples of

TABLE 1 Suggested Form for Recording Test Results

Column 1 Applied Load, kg ^A (L)	Column 2 Average Scar Diameter, mm (X)	Column 3 Compensation Scar Diameter, mm	Column 4 LD_h Factor	Column 5 Corrected Load, kg ^A (LD_h/X)
6			0.95	
8			1.40	
10		0.21	1.88	
13		0.23	2.67	
16		0.25	3.52	
20		0.27	4.74	
24		0.28	6.05	
32		0.31	8.87	
40		0.33	11.96	
50		0.36	16.10	
63		0.39	21.86	
80		0.42	30.08	
100		0.46	40.5	
126		0.50	55.2	
160		0.54	75.8	
200		0.59	102.2	
250			137.5	
315			187.1	
400			258	
500			347	
620			462	
800			649	

^A To convert from kilograms-force to newtons, multiply by 9.806.

¹ This test method is under the jurisdiction of ASTM Committee D02 on Petroleum Products and Lubricants and is the direct responsibility of Subcommittee D02.L0 on Industrial Lubricants.

Current edition approved Aug. 10, 2003. Published September 2003. Originally approved in 1969. Last previous edition approved in 1998 as D 2783-88 (1998).

This method was prepared under the joint sponsorship of the American Society of Lubrication Engineers. Accepted by ASLE January 1969.

² Annual Book of ASTM Standards, Vol 05.01.

³ Available from American National Standards Institute (ANSI), 25 W. 43rd St., 4th Floor, New York, NY 10036.

such fluids are methyl phenyl silicone, chlorinated methyl phenyl silicone, silphenylene, phenyl ether, and some mixtures of petroleum oil and chlorinated paraffins.

3.1.2 *compensation scar diameter*—the average diameter, in millimetres, of the wear scar on the stationary balls caused by the rotating ball under an applied load in the presence of a lubricant, but without causing either seizure or welding.

3.1.2.1 *Discussion*—The wear scar obtained shall be within 5 % of the values noted in **Table 1**, Column 3.

3.1.3 *corrected load*—the load in kilograms-force (or newtons) for each run obtained by multiplying the applied load by the ratio of the Hertz scar diameter to the measured scar diameter at that load.

3.1.4 *Hertz line*—a line of plot on logarithmic paper, as shown in **Fig. 1**, where the coordinates are scar diameter in millimetres and applied load in kilograms-force (or newtons), obtained under static conditions.

3.1.5 *Hertz scar diameter*—the average diameter, in millimetres, of an indentation caused by the deformation of the balls under static load (prior to test). It may be calculated from the equation

$$D_h = 8.73 \times 10^{-2}(P)^{1/3} \quad (1)$$

where:

D_h = Hertz diameter of the contact area, and

P = the static applied load.

3.1.6 *immediate seizure region*—that region of the scar-load curve characterized by seizure or welding at the startup or by large wear scars. Initial deflection of indicating pen on the optional friction-measuring device is larger than with nonseizure loads. See **Fig. 1**.

3.1.7 *incipient seizure or initial seizure region*—that region at which, with an applied load, there is a momentary breakdown of the lubricating film. This breakdown is noted by a sudden increase in the measured scar diameter and a momentary deflection of the indicating pen of the optional friction-measuring device. See **Fig. 1**.

3.1.8 *last nonseizure load*—the last load at which the measured scar diameter is not more than 5 % above the compensation line at the load. See **Fig. 1**.

3.1.9 *load-wear index* (or the load-carrying property of a lubricant)—an index of the ability of a lubricant to minimize wear at applied loads. Under the conditions of this test, specific loadings in kilograms-force (or newtons) having intervals of approximately 0.1 logarithmic units, are applied to the three stationary balls for ten runs prior to welding. The load-wear index is the average of the sum of the corrected loads determined for the ten applied loads immediately preceding the weld pair.

3.1.10 *weld point*—under the conditions of this test, the lowest applied load in kilograms at which the rotating ball welds to the three stationary balls, indicating the extreme-pressure level of the lubricants-force (or newtons) has been exceeded.

3.1.10.1 *Discussion*—Some lubricants do not allow true welding, and extreme scoring of the three stationary balls results. In such cases, the applied load which produces a maximum scar diameter of 4 mm is reported as the weld point.

4. Summary of Test Method

4.1 The tester is operated with one steel ball under load rotating against three steel balls held stationary in the form of a cradle. Test lubricant covers the lower three balls. The rotating speed is 1760 ± 40 rpm. The machine and test lubricant are brought to 18 to 35°C (65 to 95°F) and then a series of tests of 10-s duration are made at increasing loads until welding occurs. Ten tests are made below the welding point. If ten loads have not been run when welding occurs and the scars at loads below seizure are within 5 % of the compensation line (**AB Fig. 1**) no further runs are necessary. The total can be brought to ten by assuming that loads below the last nonseizure load will produce wear scars equal to the “compensation scar diameter.” Values of these “assumed” scars are given in **Table 1**. For clarification of “last nonseizure load” and “weld point” see **Fig. 1**.⁴

5. Significance and Use

5.1 This test method, used for specification purposes, differentiates between lubricating fluids having low, medium, and high level of extreme-pressure properties. The user of this method should determine to his own satisfaction whether results of this test procedure correlate with field performance or other bench test machines.

6. Apparatus

6.1 *Four-Ball Extreme-Pressure Tester*,⁵ illustrated in **Figs. 2 and 3**.

NOTE 1—It is important to distinguish between the four-ball EP tester and the four-ball wear tester. The four-ball EP tester is designed for testing under more severe conditions and lacks the sensitivity necessary for the four-ball wear test.

6.2 *Microscope*, equipped with a calibrated measuring scale and readable to an accuracy of 0.01 mm.

6.3 *Timer*, graduated in tenths of a second.

NOTE 2—Optional equipment with four-ball apparatus consists of a friction-measuring device electrically driven and conveniently graduated in 10-s markings.

7. Materials

7.1 *Cleaning Solvent*, safe, non-film forming, nonchlorinated. (**Warning**—Flammable. Harmful if inhaled. See **A1.1**.)

NOTE 3—Certain petroleum distillates, formerly used as solvents, have been eliminated due to possible toxic effects. Each user should select a solvent that can meet applicable safety requirements and thoroughly clean machine parts. Reagent Grade Stoddard solvent is an example of a solvent that has been found suitable.

7.2 *Rinse Solvent*, same as in **7.1**, but with higher volatility. ASTM *n*-Heptane is an example of one such rinse solvent that has been found suitable. (**Warning**—Flammable. Harmful if inhaled. See **A1.2**.)

⁴ Further details applicable to this method may be found in: Sayles, F. S., et al., “The Four-Ball E. P. Tester, An ASTM Method of Test,” *National Lubricating Grease Institute*, NLGIA, Vol 32, No. 5, August 1968, pp. 162–167.

⁵ Satisfactory sources of supply for this instrument are Falex Corp., 1020 Airpark Dr., Sugar Grove, IL 60554–9585 and Stanhope-Seta Ltd., Park Close, Egham, Englefield Green, Surrey, England TW20 OXD.

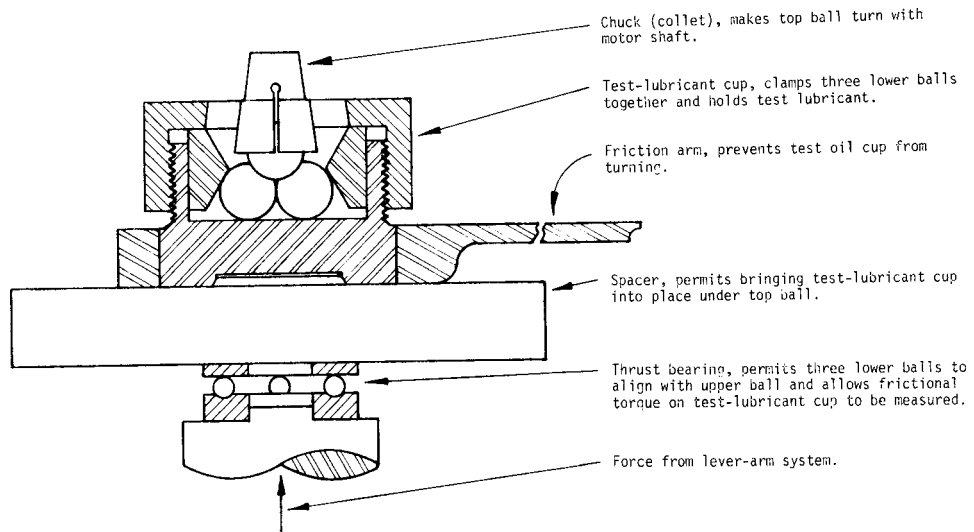

FIG. 2 Sectional View of Four-Ball Tester



FIG. 3 Four-Ball EP Test Machine

7.3 *Test Balls*⁶—Test balls shall be chrome alloy steel, made from AISI standard steel No. E-52100, with diameter of 12.7 mm (0.5 in.), Grade 25 EP (Extra Polish). Such balls are described in ANSI Specifications B 3.12, for Metal Balls. The Extra-Polish finish is not described in that specification. The Rockwell C hardness shall be 64 to 66, a closer limit than is found in the ANSI requirement.

8. Preparation of Apparatus

8.1 Thoroughly clean four new test balls, test-lubricant cup, and chuck assemblies by first washing with cleaning solvent (see 7.1) and then rinse solvent (see 7.2).

NOTE 4—Do not use solvents such as carbon tetrachloride or other solvents that may inherently possess load-carrying properties which may affect the results.

8.2 Lower the crosshead by raising the lever arm. Lock the lever arm in the raised position by means of a locking arrangement for that purpose.

9. Procedure

9.1 Place the three test balls in the test-lubricant cup. Place the lock ring over the test balls and screw down the nut securely (Note 5). Pour the lubricating fluid to be tested over the three test balls until they are covered.

NOTE 5—Subsequent independent investigations reported in 1971 by several laboratories indicate that optimum test repeatability is obtained when the force on the lock-down nut is maintained within the range $68 \pm 7 \text{ N} \cdot \text{m}$ ($50 \pm 5 \text{ ft} \cdot \text{lb}$), applied, and measured by means of a torque wrench. Significantly lower weld points were obtained when the force applied was approximately $136 \text{ N} \cdot \text{m}$ ($100 \text{ ft} \cdot \text{lb}$).

9.2 Bring the lubricant and cup to 18 to 35°C (65 to 95°F).

9.3 Press one ball into the ball chuck (Note 6) and mount the chuck into the chuck-holder.

NOTE 6—Examine the chuck and top ball after each run. If the ball shows signs of movement in the chuck, even though welding of the four-balls did not occur, the chuck should be replaced. When welding occurs slippage between ball and chuck nearly always occurs. If the chuck has metal from the top ball adhering to it, the metal must be removed or the chuck replaced.

9.4 Install the test-lubricant cup assembly on the test apparatus in contact with the fourth ball. Place the spacer between cup and thrust bearing.

9.5 Place the weight tray and sufficient weights on the horizontal arm in the correct notch for a base test load of 784 N (80 kg). Release the lever arm and gently apply (Note 7) the test load to the balls, making certain the cup assembly and spacer are centered. If the optional friction-measuring device is used, connect the calibrated arm on the test-lubricant cup to the indicator spring by means of the clip and wire.

NOTE 7—Shock-loading should be avoided as it may deform the balls permanently.

9.6 Start the motor and run for $10 \pm 0.2 \text{ s}$.

NOTE 8—The time for the apparatus to “coast” to a stop is not considered.

9.7 Remove the test-lubricant cup assembly; remove the chuck and discard the ball.

9.8 Measure the scar diameter of test balls as follows:

9.8.1 *Option A*—Remove the test balls. Clean the balls with cleaning solvent (see 7.1) and then rinse solvent (see 7.2). Wipe dry with a soft cloth. Place the individual balls on a suitable holder and by means of a microscope, measure to the nearest 0.01 mm the scar diameters both parallel (horizontal) and normal (vertical) to the striations in the scar surface of one of the three test balls (Note 9).

9.8.2 *Option B*—Leave the balls clamped in the cup. Pour out the lubricating fluid. Wash the ball surfaces with cleaning solvent (see 7.1) and then the rinse solvent (see 7.2). Using a microscope, measure to the nearest 0.01 mm the scar diameters both parallel (horizontal) and normal (vertical) to the striations in the scar surface of one of the three test balls (Note 9).

9.8.3 Measurements by microscope of the scar diameters on all three balls, rather than one ball as outlined in Options A or B, may be made if the operator so desires.

NOTE 9—It is recommended that prior to selection of Option A or B, the operator examines visually the test balls to ascertain no gross discrepancy in the wear scars formed on the test balls; if discrepancy is noted, then wear scar measurements on all three test balls must be made.

9.9 Record (Table 1, Column 2) for the 784 N (80-kg) load the average scar diameter by any one of the three techniques described in 9.8. Compare this average scar diameter with the compensation scar diameter (Table 1, Column 3).

9.10 Make additional runs at consecutively higher test loads (Table 1, Column 1), recording the measured scar diameter(s) (Note 10) and discarding test balls, until welding occurs (Note 11). Make a check run at this point. If welding does not occur on the check run, repeat the test at the next higher load until welding is verified.

NOTE 10—Measuring the scar diameter(s) of test balls in the incipient and immediate seizure region is sometimes difficult due to the flow of metal obliterating the full contact area formed by the rotating ball. In such cases the metal flow can generally be removed or peeled off with a suitable instrument. See Figs. 4 and 5. If the scar periphery is obscure or not well

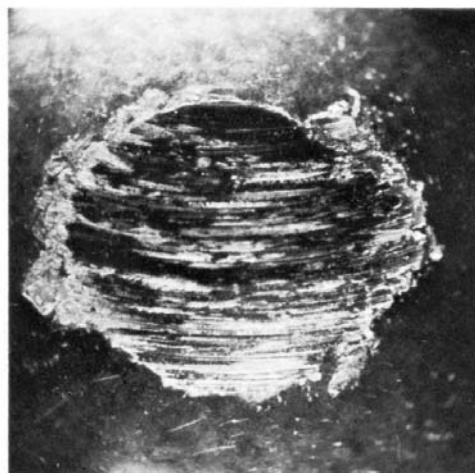

FIG. 4 Typical Test Ball Scars—Before Removal

⁶ Steel balls meeting this description were used in developing the precision of the test. They are available from the manufacturer of the test machine. All balls used in one test should be taken from one carton (of 500 balls) as received from the supplier.