**Stationary source emissions — Manual
determination of mass concentration of
particulate matter**

*Émissions de sources fixes — Détermination manuelle de la
concentration en masse de poussières*

iTeh STANDARD PREVIEW
(standards.iteh.ai)

[ISO 9096:2003](https://standards.iteh.ai/catalog/standards/sist/f83625eb-72f2-4543-8462-ce9285bdd40e/iso-9096-2003)

[https://standards.iteh.ai/catalog/standards/sist/f83625eb-72f2-4543-8462-
ce9285bdd40e/iso-9096-2003](https://standards.iteh.ai/catalog/standards/sist/f83625eb-72f2-4543-8462-ce9285bdd40e/iso-9096-2003)



PDF disclaimer

This PDF file may contain embedded typefaces. In accordance with Adobe's licensing policy, this file may be printed or viewed but shall not be edited unless the typefaces which are embedded are licensed to and installed on the computer performing the editing. In downloading this file, parties accept therein the responsibility of not infringing Adobe's licensing policy. The ISO Central Secretariat accepts no liability in this area.

Adobe is a trademark of Adobe Systems Incorporated.

Details of the software products used to create this PDF file can be found in the General Info relative to the file; the PDF-creation parameters were optimized for printing. Every care has been taken to ensure that the file is suitable for use by ISO member bodies. In the unlikely event that a problem relating to it is found, please inform the Central Secretariat at the address given below.

iTeh STANDARD PREVIEW
(standards.iteh.ai)

[ISO 9096:2003](#)

<https://standards.iteh.ai/catalog/standards/sist/f83625eb-72f2-4543-8462-ce9285bdd40e/iso-9096-2003>

© ISO 2003

All rights reserved. Unless otherwise specified, no part of this publication may be reproduced or utilized in any form or by any means, electronic or mechanical, including photocopying and microfilm, without permission in writing from either ISO at the address below or ISO's member body in the country of the requester.

ISO copyright office
Case postale 56 • CH-1211 Geneva 20
Tel. + 41 22 749 01 11
Fax + 41 22 749 09 47
E-mail copyright@iso.org
Web www.iso.org

Published in Switzerland

Contents

Page

Foreword.....	iv
Introduction	v
1 Scope.....	1
2 Normative references	1
3 Terms and definitions.....	1
4 Principle	4
4.1 General.....	4
4.2 Interferences.....	5
5 Sampling plane and sampling points	5
5.1 General.....	5
5.2 Sampling plane.....	6
5.3 Requirements for sampling points.....	6
5.4 Minimum number and location of sampling points.....	6
5.5 Access ports.....	7
5.6 Sampling time.....	7
6 Apparatus and materials	8
6.1 Gas velocity, temperature, pressure, and gas composition measurement devices.....	8
6.2 Sampling equipment.....	8
6.3 Equipment for particulate matter recovery	14
6.4 Equipment for conditioning and weighing.....	14
7 Sampling and weighing procedures.....	15
7.1 General aspects	15
7.2 Weighing procedure	16
7.3 Sampling	18
7.4 Validation of results.....	21
8 Additional aspects	22
8.1 Thermal behaviour of particulate matter	22
8.2 Particulate deposits upstream of the filter	24
8.3 Improvement of the weighing procedure	24
9 Calculations.....	24
9.1 Isokinetic flowrate.....	24
9.2 Dust concentration	25
10 Performance characteristics.....	26
10.1 General aspects	26
10.2 Experimental data for sampling	27
11 Test report	27
Annex A (normative) Proven design of the entry nozzle.....	29
Annex B (normative) Determination of positions of sampling points in circular and rectangular ducts.....	30
Annex C (informative) Examples of weighing bias	34
Annex D (informative) Isokinetic sampling conditions.....	36
Annex E (informative) Summary validation information	38
Annex F (informative) Examples of suitable access ports for sampling equipment.....	41

Foreword

ISO (the International Organization for Standardization) is a worldwide federation of national standards bodies (ISO member bodies). The work of preparing International Standards is normally carried out through ISO technical committees. Each member body interested in a subject for which a technical committee has been established has the right to be represented on that committee. International organizations, governmental and non-governmental, in liaison with ISO, also take part in the work. ISO collaborates closely with the International Electrotechnical Commission (IEC) on all matters of electrotechnical standardization.

International Standards are drafted in accordance with the rules given in the ISO/IEC Directives, Part 2.

The main task of technical committees is to prepare International Standards. Draft International Standards adopted by the technical committees are circulated to the member bodies for voting. Publication as an International Standard requires approval by at least 75 % of the member bodies casting a vote.

Attention is drawn to the possibility that some of the elements of this document may be the subject of patent rights. ISO shall not be held responsible for identifying any or all such patent rights.

ISO 9096 was prepared by Technical Committee ISO/TC 146, *Air quality*, Subcommittee SC 1, *Stationary source emissions*.

This second edition cancels and replaces the first edition (ISO 9096:1992), which has been technically revised.

iTeh STANDARD PREVIEW
(standards.iteh.ai)

ISO 9096:2003
<https://standards.iteh.ai/catalog/standards/sist/f83625eb-72f2-4543-8462-ce9285bdd40e/iso-9096-2003>

Introduction

Close liaison and cooperation between ISO/TC 146/SC 1 and CEN/TC 264 has resulted in the preparation of this International Standard (ISO 9096), ISO 12141 and European Standard EN 13824-1. This International Standard is similar to EN 13284-1 with additional emphasis given on the use of high-volume sampling techniques. A representative, integrated sample is extracted from the flue gas and particulate matter entrained in the gas sample is separated by a filter. The pre-weighed filter is subsequently dried and weighed. A relative increase in the mass is attributed to the collection of particulate matter on the filter.

To meet the specifications of this International Standard, the particulate sample must be weighed to a specified level of accuracy. This level of accuracy is achieved by:

- a) exercising extreme care in weighing, in accordance with the procedures of this International Standard;
- b) extending the sampling time at conventional sampling rates;
- c) sampling at higher rates for conventional sampling times (high-volume sampling);
- d) recovering all dust upstream of the filter.

iTeh STANDARD PREVIEW (standards.iteh.ai)

[ISO 9096:2003](https://standards.iteh.ai/catalog/standards/sist/f83625eb-72f2-4543-8462-ce9285bdd40e/iso-9096-2003)

<https://standards.iteh.ai/catalog/standards/sist/f83625eb-72f2-4543-8462-ce9285bdd40e/iso-9096-2003>

iTeh STANDARD PREVIEW
(standards.iteh.ai)

[ISO 9096:2003](#)

<https://standards.iteh.ai/catalog/standards/sist/f83625eb-72f2-4543-8462-ce9285bdd40e/iso-9096-2003>

Stationary source emissions — Manual determination of mass concentration of particulate matter

1 Scope

This International Standard describes a reference method for the measurement of particulate matter (dust) concentration in waste gases of concentrations from 20 mg/m³ to 1000 mg/m³ under standard conditions.

This International Standard is applicable to the calibration of automated monitoring systems (AMS). If the emission gas contains unstable, reactive or semi-volatile substances, the measurement will depend on the filtration temperature. In-stack methods may be more applicable than out-stack methods for the calibration of automated monitoring systems.

2 Normative references

The following referenced documents are indispensable for the application of this document. For dated references, only the edition cited applies. For undated references, the latest edition of the referenced document (including any amendments) applies.

ISO 5725 (all parts), *Accuracy (trueness and precision) of measurement methods and results*

ISO 10780, *Stationary source emissions — Measurement of velocity and volume flowrate of gas streams in ducts*

ISO 12141, *Stationary source emissions — Determination of mass concentration of particulate matter (dust) at low concentrations — Manual gravimetric method*

3 Terms and definitions

For the purposes of this document, the following terms and definitions apply.

3.1

particulate matter

dust

particles, of any shape, structure or density, dispersed in the gas phase under the sampling conditions

NOTE 1 In the method described, all the compounds that may be collected by filtration under specified conditions after representative sampling of the gas to be analysed, and which remain upstream of the filter and on the filter after drying under specified conditions, are considered to be dust (or particulate matter). However, for the purposes of some national standards, the definition of particulate matter may extend to condensibles or reaction products collected under specified conditions (e.g. temperatures lower than the flue gas temperature).

NOTE 2 This method restricts the definition of particulate matter to that material collected in the sampling system on and before a filter, under specified temperature conditions. Procedures for the measurement of secondary particulate matter (condensable materials) formed and collected after the filter are not within the scope of this International Standard.

**3.2
filtration temperature**

temperature of the sampled gas immediately downstream of the filter

**3.3
in-stack filtration**

filtration in the duct with the filter in its filter holder placed immediately downstream of the sampling nozzle

**3.4
out-stack filtration**

filtration outside of the duct with the filter in its heated filter holder placed downstream of the sampling nozzle and the suction tube (sampling probe)

**3.5
isokinetic sampling**

sampling at a flowrate such that the velocity and direction of the gas entering the sampling nozzle (v_n) are the same as that of the gas in the duct at the sampling points v_s

See Figure 1.

NOTE The velocity ratio v_n/v_s expressed as a percentage characterizes the deviation from isokinetic sampling.

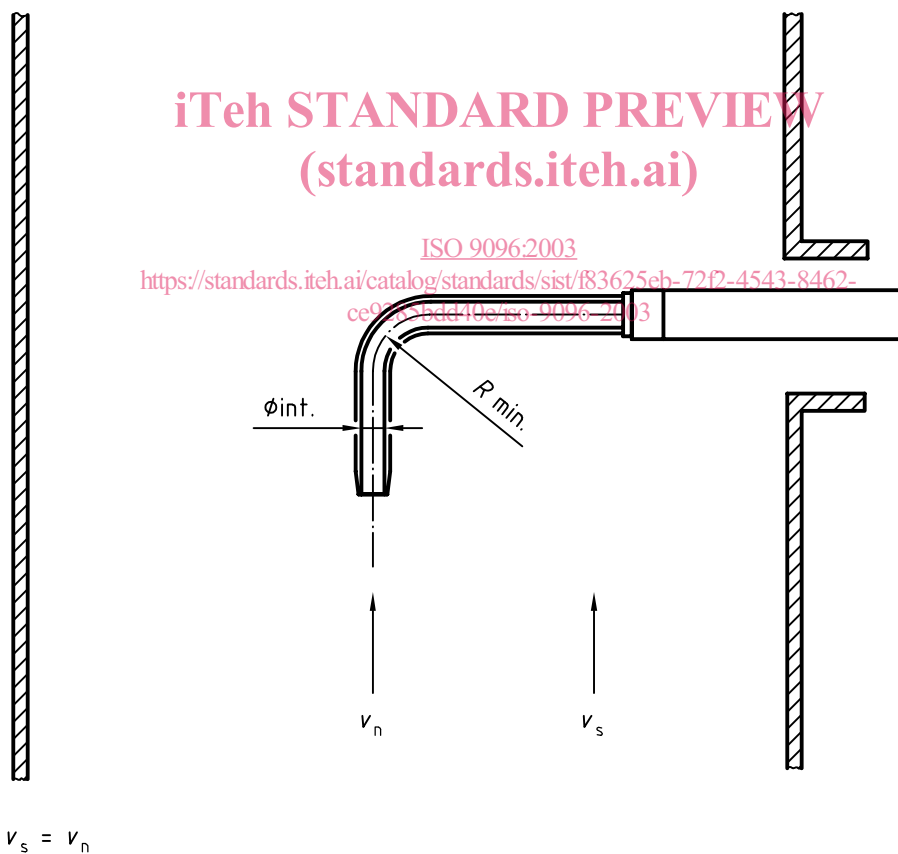

Key

- v_s stack gas velocity
- v_n velocity in the nozzle

Figure 1 — Isokinetic sampling

3.6 hydraulic diameter

d_h
characteristic dimension of a duct cross-section

$$d_h = \frac{4 \times A_s}{l_s} \quad (1)$$

where

A_s is the cross-sectional area of the sampling plane;

l_s is the length of the perimeter of the sampling plane

3.7 sampling plane

plane normal to the centreline of the duct at the sampling position

See Figure 2.

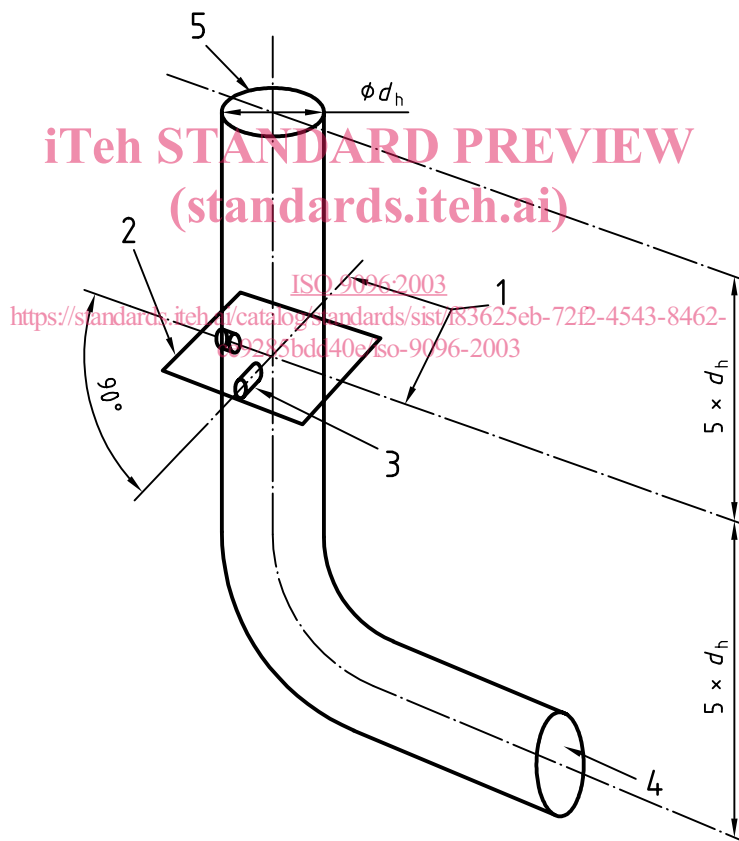

Key

- 1 sampling lines
- 2 sampling plane
- 3 access port
- 4 flow
- 5 top of duct

Figure 2 — Illustration of definitions in relation to a circular duct

**3.8
sampling line**

line in the sampling plane along which sampling points are located, bounded by the inner duct wall

See Figure 2.

**3.9
sampling point**

the specific position on a sampling line at which a sample is extracted

**3.10
standard conditions**

gas pressure and temperature constants and conditions to which volumetric calculations are referred

NOTE For the purposes of this International Standard, standard conditions are 101,325 kPa rounded to 101,3 kPa; 273,15 K rounded to 273 K; dry gas.

**3.11
overall blank**

test sample taken at the plant site in an identical manner to the normal samples in the series, except that no gas is sampled during the test duration

NOTE The measured mass variation provides an estimation of the uncertainties. The overall blank value, divided by the average sampling volume of the measurement series, provides an estimation of the detection limit (milligrams per cubic metre) of the whole measurement process, as carried out by the operator. The overall blank includes possible deposits on the filter and on all parts upstream.

ITEH STANDARD PREVIEW
(standards.iteh.ai)

**3.12
weighing control procedures**

quality control procedures utilised for detecting/correcting apparent mass variations due to climatic or environmental changes between pre- and post-sampling weighing series

<https://standards.iteh.ai/catalog/standards/sist/f83625eb-72f2-4543-8462->

NOTE In these procedures, control parts are used (see 7.2) which are identical to those to be weighed for dust measurement and are pre-treated under the same conditions of temperature and humidity. The control parts are kept free from dust contamination.

**3.13
measurement series**

successive measurements carried out in the same sampling plane, and under the same process conditions

**3.14
limit value**

dust concentration that is permitted by authorities for the plant process (i.e. average limit value)

NOTE For purposes other than regulatory uses, the measurement value is compared to a stated reference value.

4 Principle

4.1 General

A sample stream of the gas is extracted from the main gas stream at specified sampling points for a measured period of time, with an isokinetic controlled flowrate. The volume of gas collected is measured, and a pre-weighed filter, which is then dried and reweighed, separates the particulate matter (dust) entrained in the gas sample. Deposits upstream of the filter in the sampling equipment are also recovered and weighed. The increase in mass of the filter and the mass deposited upstream of the filter is attributed to particulate matter collected from the sampled gas. The ratio of the mass of the particulate matter collected to the volume of gas collected allows the flue gas particulate concentration to be calculated.

Valid measurements can be achieved only when:

- a) an adequate quantity of dust is collected during the sampling, which is at least 5 times the corresponding overall blank value;
- b) the gas stream in the duct at the sampling location has a sufficiently steady and identified velocity, temperature and pressure, and a sufficiently homogeneous composition;
- c) the flow of gas is parallel to the axis of the nozzle;
- d) sampling is carried out without disturbance of the gas stream, using a sharp-edged nozzle facing into the stream;
- e) isokinetic sampling conditions are maintained throughout the test;
- f) samples are taken at a preselected number of stated positions in the sampling plane to permit obtaining a representative sample for a non-uniform distribution of particulate matter in the duct or stack;
- g) the sampling train is designed and operated to avoid condensation and to be leak-free;
- h) calibration criteria are satisfied;
- i) sampling blank and leak-check criteria are met;
- j) dust deposits upstream of the filter are recovered and/or taken into account;
- k) the sampling and weighing procedures are adapted to the expected dust quantities as specified in this International Standard.

4.2 Interferences

ISO 9096:2003

<https://standards.iteh.ai/catalog/standards/sist/f83625eb-72f2-4543-8462-ce9285bdd40e/iso-9096-2003>

a) Positive interference

Gaseous species present in stack gases that are capable of reacting to form particulate matter within the sample train can result in positive interference. Examples include the potential reaction of sulfur dioxide (SO₂) to an insoluble sulfate compound in the high-humidity portion of the system, such as with limestone in flue gas following a wet flue-gas desulfurization system (FGDS) to form calcium sulfate (CaSO₄), or the reaction with ammonia gas (NH₃) to form ammonium sulfate (NH₄SO₄) [see 7.1 a)].

b) Negative interference

- 1) Certain acid gaseous species can erode the filter material, resulting in negative interference. For example the reaction of hydrogen fluoride (HF) with glass components in the sample train (see 6.2.5).
- 2) Volatile matter existing in solid or liquid form in the stack gas may vaporize after collection on the sample train filtration material, due to continued exposure to the hot sample stream during the sampling period. Such occurrence would result in a negative interference (see 8.1).

5 Sampling plane and sampling points

5.1 General

Representative sampling is possible when a suitable location is available, having a sufficiently homogeneous gas velocity at the sampling plane.

Sampling shall be carried out at a sufficient number of sampling points, usually located on several sampling lines. Convenient access ports and a working platform shall be available for the testing.

5.2 Sampling plane

The sampling plane shall be situated in a length of straight duct (preferably vertical) with a constant shape and cross-sectional area. The sampling plane shall be as far downstream and upstream as possible from any obstruction that may cause a disturbance and produce a change in the direction of flow (disturbances caused by e.g. bends, fans or pollution abatement equipment).

5.3 Requirements for sampling points

Preliminary measurements at all the sampling points defined in 5.4 and Annex B shall prove that the gas stream in the sampling plane meets the following requirements:

- a) the angle of gas flow is less than 15° with regard to the duct axis (a recommended method for estimation is indicated in Annex C of ISO 10780:1994);
- b) no local negative flow is present;
- c) the minimum velocity is higher than the detection limit of the method used for the flowrate measurement (for Pitot tubes, a differential pressure larger than 5 Pa);
- d) the ratio of the highest to lowest local gas velocities is less than 3:1.

If the above requirements cannot be met, the uncertainty will be higher than that specified by this International Standard and the sampling location is not in compliance with this International Standard (see 7.4.6).

The above requirements are generally fulfilled in sections of duct with at least five hydraulic diameters of straight duct upstream of the sampling plane and two hydraulic diameters downstream (five hydraulic diameter from the top of a stack). Therefore, it is strongly recommended that sampling locations be selected accordingly.

5.4 Minimum number and location of sampling points

The dimensions of the sampling plane dictate the minimum number of sampling points. In general, this number increases as the duct dimensions increase.

Tables 1 and 2 give the minimum number of sampling points to be used for circular and rectangular ducts respectively. The sampling points shall be located at the centres of equal areas in the sampling plane (in accordance with Annex B).

Sampling points shall not be located within 3 % of the sampling line length (if $d > 1,5$ m) or 5 cm (if $d < 1,5$ m) from the inner duct wall. Choose the inner edge of the area when calculations result in sampling point positions within this area. This may arise when selecting more than the minimum numbers of sampling points presented in Tables 1 and 2, for example in cases of unusual duct shape.

NOTE When the requirements for the sampling plane (see 5.2) cannot be met, it may be possible to improve representative sampling by increasing the number of sampling points above those specified in Tables 1 and 2. See also 7.3.2 for sampling-point premeasurement procedures.

Table 1 — Minimum number of sampling points for circular ducts

Range of duct diameters m	Minimum number of sampling lines (diameters)	Minimum number of sampling points per line		Minimum number of sampling points per plane	
		incl. centre point	excl. centre point	incl. centre point	excl. centre point
< 0,35	—	1 ^a	—	1 ^a	—
0,35 to 0,70	2	3	2	5	4
0,70 to 1,00	2	5	4	9	8
1,00 to 2,00	2	7	6	13	12
> 2,00	2	9	8	17	16

^a Using only one sampling point can give rise to errors greater than those specified in this International Standard.

Table 2 — Minimum number of sampling points for rectangular ducts

Range of sampling plane areas m ²	Minimum number of side divisions ^a	Minimum number of sampling points per plane
< 0,09	—	1 ^b
0,09 to 0,38	2	4
0,38 to 1,50	3	9
> 1,50	4	16

^a Other side divisions may be necessary, for example if the longest duct side length is more than twice the length of the shortest side.

^b Using only one sampling point can give rise to errors greater than those specified in this International Standard.

5.5 Access ports

Ports shall be provided for access to the sampling points selected in accordance with Annex B.

The port dimensions shall provide space for the insertion and removal of the sampling equipment and associated devices, and allow for sealing once the sampling equipment is in place. A minimum diameter of 125 mm or a surface area of 100 mm × 250 mm are recommended, except for small ducts (less than 0,7 m diameter) for which the port size needs to be smaller (see Annex F for examples).

5.6 Sampling time

Assuming a volumetric flowrate characteristic of the sampling train to be used, a sampling time can be calculated that will lead to the collection of a desired or required mass of particulate matter if the approximate particulate concentration is known previously.

If the expected dust concentration (c_{exp}) has been previously determined or assumed and the mass of particulate matter (m) to be collected is required or set, then the necessary volume of the flue gas to be sampled is:

$$V_n = \frac{m}{c_{\text{exp}}} \quad (2)$$

However, the volume of the sample, V_n (litres) will be equal to the total sampling time, t (min), multiplied by the nozzle volumetric flowrate under actual conditions, Q_a (l/min), i.e. $V_n = tQ_a$.

The total sampling time in the sampling plane is thus estimated to be:

$$t = \frac{V_n}{Q_a} \text{ or } t = \frac{m}{c_{\text{exp}} \cdot Q_a} \quad (3)$$

6 Apparatus and materials

6.1 Gas velocity, temperature, pressure, and gas composition measurement devices

Velocity measurements shall be carried out using standard Pitot tubes or other measurement devices, e.g. S-Type Pitot tubes, provided they are calibrated against standardized Pitot tubes in accordance with ISO 10780.

The temperature and the pressure in the duct shall be measured in order to calculate the actual density of the gas within $\pm 0,05 \text{ kg/m}^3$, also taking the gas composition into account.

When expressing dust concentrations on a dry basis, and/or where the concentrations are to be expressed in relation to a reference oxygen or CO_2 concentration, humidity (moisture) and/or oxygen/ CO_2 measurements shall be carried out in the vicinity of the sampling plane.

Specifications for this apparatus are given in Table 3.

6.2 Sampling apparatus iTech STANDARD PREVIEW

The sampling train consists principally of (standards.iteh.ai)

- a) a suction tube (sampling probe) with entry nozzle,
- b) a filter housing, including a filter support and a filter, either located in the duct (in-stack filtration), or placed outside the duct (out-stack filtration), leading to slightly different kinds of sampling trains. In the presence of water droplets, out-stack filtration shall be used,
- c) a suction unit, with a gas metering system.

6.2.1 Filtration device

- a) **“In-stack” filtration devices** (Figure 3): the part of the tubing between the nozzle and the filter shall be very short, to minimize dust deposits upstream of the filter. The tubing after the filter (suction tube) shall be of sufficient length to traverse the duct at the required sampling points. Since the filtration temperature is generally identical to that of the gas in the duct, filter clogging may occur if the gas contains water droplets.

To allow traversing of the duct, a leak-free, rigid tube (support tube) of sufficient length is used downstream of the filter housing for mechanical support of the nozzle and filter housing;

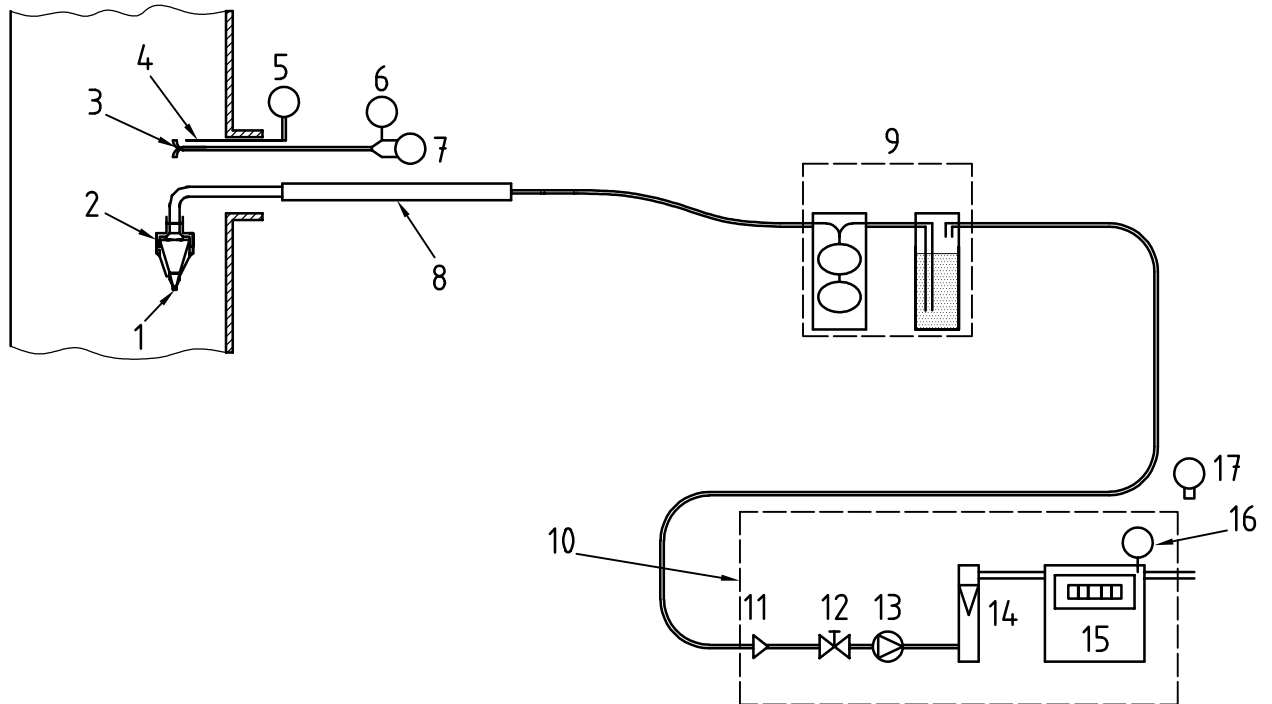

Key

- | | | | |
|---|-----------------------------------|----|--------------------------------------|
| 1 | entry nozzle | 10 | suction unit and gas-metering device |
| 2 | filter holder | 11 | shut-off valve |
| 3 | Pitot tube | 12 | adjustment valve |
| 4 | temperature probe | 13 | pump |
| 5 | temperature measurement | 14 | flowmeter |
| 6 | static pressure measurement | 15 | dry gas volumeter |
| 7 | differential pressure measurement | 16 | temperature measurement |
| 8 | support tube (in-stack device) | 17 | barometer |
| 9 | cooling and drying system | | |

Figure 3 — Example of sampling on a dry basis with an “in-stack” filter

b) **“Out-stack” filtration devices** (Figure 4): the part of the tubing between the nozzle and the filter (suction tube) has to be of sufficient length to traverse the duct at the required sample points. The suction tube and the filter housing is temperature-controlled, to provide vaporization of possible water droplets and avoid filtration difficulties related to acid gases having high dew points.