



Designation: B 26/B 26M – 03

Standard Specification for Aluminum-Alloy Sand Castings¹

This standard is issued under the fixed designation B 26/B 26M; the number immediately following the designation indicates the year of original adoption or, in the case of revision, the year of last revision. A number in parentheses indicates the year of last reappraisal. A superscript epsilon (ϵ) indicates an editorial change since the last revision or reappraisal.

This standard has been approved for use by agencies of the Department of Defense.

1. Scope*

1.1 This specification² covers aluminum-alloy sand castings designated as shown in [Table 1](#).

1.2 This specification is not intended for aluminum-alloy sand castings used in aerospace applications.

1.3 Alloy and temper designations are in accordance with ANSI H35.1 and H35.1M. Unified Numbering System alloy designations are in accordance with Practice E 527.

1.4 Unless the order specifies the “M” specification designation, the material shall be furnished to the inch-pound units.

1.5 For acceptance criteria for inclusion of new aluminum and aluminum alloys and their properties in this specification, see [Annex A1](#) and [Annex A2](#).

1.6 The values stated in either inch-pound units or SI units are to be regarded separately as standards. The SI units are shown in brackets or in separate tables or columns. The values stated in each system are not exact equivalents; therefore, each system must be used independent of the other. Combining values from the two systems may result in nonconformance with the specification.

1.7 This standard does not purport to address all of the safety concerns, if any, associated with its use. It is the responsibility of the user of this standard to establish appropriate safety and health practices and determine the applicability of regulatory limitations prior to use.

2. Referenced Documents

2.1 The following documents of the issue in effect on date of material purchase form a part of this specification to the extent referenced herein:

2.2 ASTM Standards:

[B 179](#) Specification for Aluminum Alloys in Ingot and Molten Forms for Castings from All Casting Processes³

[B 275](#) Practice for Codification of Certain Nonferrous Metals and Alloys, Cast and Wrought³

[B 557](#) Test Methods for Tension Testing Wrought and Cast Aluminum- and Magnesium-Alloy Products³

[B 557M](#) Test Methods for Tension Testing Wrought and Cast Aluminum- and Magnesium-Alloy Products [Metric]³

[B 660](#) Practices for Packaging/Packing of Aluminum and Magnesium Products³

[B 881](#) Terminology Relating to Aluminum- and Magnesium-Alloy Products³

[B 917/B 917M](#) Practice for Heat Treatment of Aluminum-Alloy Castings from All Processes³

[D 3951](#) Practice for Commercial Packaging⁴

[E 29](#) Practice for Using Significant Digits in Test Data to Determine Conformance with Specifications⁵

[E 34](#) Test Methods for Chemical Analysis of Aluminum and Aluminum Base-Alloys⁶

[E 88](#) Practice for Sampling Nonferrous Metals and Alloys in Cast Form for Determination of Chemical Composition⁶

[E 94](#) Guide for Radiographic Testing⁷

[E 155](#) Reference Radiographs for Examination of Aluminum and Magnesium Castings⁷

[E 165](#) Test Method for Liquid Penetrant Examination⁷

[E 527](#) Practice for Numbering Metals and Alloys (UNS)⁸

[E 607](#) Test Method for Optical Emission Spectrometric Analysis of Aluminum and Aluminum Alloys by the Point-to-Plane Technique, Nitrogen Atmosphere⁶

[E 716](#) Practices for Sampling Aluminum and Aluminum Alloys for Spectrochemical Analysis⁶

[E 1251](#) Test Method for Optical Emission Spectrometric Analysis of Aluminum and Aluminum Alloys by the Argon Atmosphere, Point-to-Plane, Unipolar Self-Initiating Capacitor Discharge⁶

[IEEE/ASTM SI 10](#) Standard for Use of the International System of Units (SI): The Modern Metric System⁵

2.3 AMS Standard:

[AMS 2771](#) Heat Treatment of Aluminum Alloy Castings⁹

2.4 American National Standards:

¹ This specification is under the jurisdiction of ASTM Committee B07 on Light Metals and Alloys and is the direct responsibility of Subcommittee B07.01 on Aluminum Alloy Ingots and Castings.

Current edition approved Apr. 10, 2003. Published September 2003. Originally approved in 1918. Last previous edition approved in 2002 as B 26/B 26M – 02.

² For ASME Boiler and Pressure Vessel Code applications see related Specification SB-26/SB-26M in Section II of that Code.

³ *Annual Book of ASTM Standards*, Vol 02.02.

⁴ *Annual Book of ASTM Standards*, Vol 15.09.

⁵ *Annual Book of ASTM Standards*, Vol 14.02.

⁶ *Annual Book of ASTM Standards*, Vol 03.05.

⁷ *Annual Book of ASTM Standards*, Vol 03.03.

⁸ *Annual Book of ASTM Standards*, Vol 01.01.

⁹ Available from Society of Automotive Engineers (SAE), 400 Commonwealth Dr., Warrendale, PA 15096-0001.

*A Summary of Changes section appears at the end of this standard.

TABLE 1 Chemical Composition Limits

NOTE 1—When single units are shown, these indicate the maximum amounts permitted.

NOTE 2—Analysis shall be made for the elements for which limits are shown in this table.

NOTE 3—The following applies to all specified limits in this table: For purposes of determining conformance to these limits, an observed value or a calculated value obtained from analysis shall be rounded to the nearest unit in the last right-hand place of figures used in expressing the specified limit in accordance with the rounding method of Practice E 29.

Alloy		Aluminum	Composition, (Values in Weight Percent)										Others	
ANSI	UNS		Silicon	Iron	Copper	Man-ganese	Magne-sium	Chromium	Nickel	Zinc	Tin	Titanium	Each	Total
201.0	A02010	remainder	0.10	0.15	4.0–5.2	0.20–0.50	0.15–0.55	0.15–0.35	0.05 ^A	0.10
204.0	A02040	remainder	0.20	0.35	4.2–5.0	0.10	0.15–0.35	...	0.05	0.10	0.05	0.15–0.30	0.05	0.15
242.0	A02420	remainder	0.7	1.0	3.7–4.5	0.35	1.2–1.8	0.25	1.7–2.3	0.35	...	0.25	0.05	0.15
A242.0	A12420	remainder	0.6	0.8	3.7–4.5	0.10	1.2–1.7	0.15–0.25	1.8–2.3	0.10	...	0.07–0.20	0.05	0.15
295.0	A02950	remainder	0.7–1.5	1.0	4.0–5.0	0.35	0.03	0.35	...	0.25	0.05	0.15
319.0	A03190	remainder	5.5–6.5	1.0	3.0–4.0	0.50	0.10	...	0.35	1.0	...	0.25	...	0.50
328.0	A03280	remainder	7.5–8.5	1.0	1.0–2.0	0.20–0.6	0.20–0.6	0.35	0.25	1.5	...	0.25	...	0.50
355.0	A03550	remainder	4.5–5.5	0.6 ^B	1.0–1.5	0.50 ^B	0.40–0.6	0.25	...	0.35	...	0.25	0.05	0.15
C355.0	A33550	remainder	4.5–5.5	0.20	1.0–1.5	0.10	0.40–0.6	0.10	...	0.20	0.05	0.15
356.0	A03560	remainder	6.5–7.5	0.6 ^B	0.25	0.35 ^B	0.20–0.45	0.35	...	0.25	0.05	0.15
A356.0	A13560	remainder	6.5–7.5	0.20	0.20	0.10	0.25–0.45	0.10	...	0.20	0.05	0.15
443.0	A04430	remainder	4.5–6.0	0.8	0.6	0.50	0.05	0.25	...	0.50	...	0.25	...	0.35
B443.0	A24430	remainder	4.5–6.0	0.8	0.15	0.35	0.05	0.35	...	0.25	0.05	0.15
512.0	A05120	remainder	1.4–2.2	0.6	0.35	0.8	3.5–4.5	0.25	...	0.35	...	0.25	0.05	0.15
514.0	A05140	remainder	0.35	0.50	0.15	0.35	3.5–4.5	0.15	...	0.25	0.05	0.15
520.0	A05200	remainder	0.25	0.30	0.25	0.15	9.5–10.6	0.15	...	0.25	0.05	0.15
535.0	A05350	remainder	0.15	0.15	0.05	0.10–0.25	6.2–7.5	0.10–0.25	0.05 ^C	0.15
705.0	A07050	remainder	0.20	0.8	0.20	0.40–0.6	1.4–1.8	0.20–0.40	...	2.7–3.3	...	0.25	0.05	0.15
707.0	A07070	remainder	0.20	0.8	0.20	0.40–0.6	1.8–2.4	0.20–0.40	...	4.0–4.5	...	0.25	0.05	0.15
710.0 ^D	A07100	remainder	0.15	0.50	0.35–0.65	0.05	0.6–0.8	6.0–7.0	...	0.25	0.05	0.15
712.0 ^D	A07120	remainder	0.30	0.50	0.25	0.10	0.50–0.65	0.40–0.6	...	5.0–6.5	...	0.15–0.25	0.05	0.20
713.0	A07130	remainder	0.25	1.1	0.40–1.0	0.6	0.20–0.50	0.35	0.15	7.0–8.0	...	0.25	0.10	0.25
771.0	A07710	remainder	0.15	0.15	0.10	0.10	0.8–1.0	0.06–0.20	...	6.5–7.5	...	0.10–0.20	0.05	0.15
850.0	A08500	remainder	0.7	0.7	0.7–1.3	0.10	0.10	...	0.7–1.3	...	5.5–7.0	0.20	...	0.30
851.0 ^D	A08510	remainder	2.0–3.0	0.7	0.7–1.3	0.10	0.10	...	0.30–0.7	...	5.5–7.0	0.20	...	0.30
852.0 ^D	A08520	remainder	0.40	0.7	1.7–2.3	0.10	0.6–0.9	...	0.9–1.5	...	5.5–7.0	0.20	...	0.30

^A Contains silver 0.40–1.0 %.

^B If iron exceeds 0.45 %, manganese content shall not be less than one half of the iron content.

^C Contains beryllium 0.003–0.007 %, boron 0.005 % max.

^D 710.0 formerly A712.0, 712.0 formerly D712.0, 851.0 formerly A850.0, 852.0 formerly B850.0.

ASTM B26/B26M-03

H35.1 Alloy and Temper Designation System for Aluminum¹⁰

H35.1M Alloy and Temper Designation System for Aluminum [Metric]¹⁰

2.5 Military Standards:

MIL-STD-129 Marking for Shipment and Storage¹¹

MIL-STD-276 Impregnation of Porous Nonferrous Metal Castings¹¹

NAVSEA Technical Publication S9074-AR-GIB-010/278¹¹

2.6 Federal Standard:

FED. STD. No. 123 Marking for Shipment (Civil Agencies)¹¹

3. Terminology

3.1 *Definitions*—Refer to Terminology B 881 for definitions of product terms used in this specification.

3.2 *sand casting*—a metal object produced by pouring molten metal into a sand mold and allowing it to solidify.

¹⁰ Annual Book of ASTM Standards, Vol 02.02, in the Related Material section (gray pages).

¹¹ Available from Standardization Documents, Order Desk, Bldg. 4, Section D, 700 Robbins Ave., Philadelphia, PA 19111-5094, Attn: NPODS.

4. Ordering Information

4.1 Orders for material under this specification shall include the following information (1.4 and 1.5):

4.1.1 This specification designation (which includes the number, year, and revision letter, if applicable),

NOTE 1—For inch-pound application, specify Specification B 26 and for metric application specify Specification B 26M. Do not mix units.

4.1.2 The quantity in either pieces or pounds [kilograms].

4.1.3 Alloy (Section 7 and Table 1),

4.1.4 Temper (Section 12 and Table 2),

4.1.5 Applicable drawing or part number,

4.2 Additionally, orders for material to this specification shall include the following information when required by the purchaser:

4.2.1 Whether chemical analysis and tensile property reports are required (Table 1 and Table 2),

4.2.2 Whether castings or test bars, or both, may be artificially aged for Alloys 705.0-T5, 707.0-T5, 712.0-T5 and 713.0-T5 (12.2) and whether yield strength tests are required for these alloys,

4.2.3 Whether test specimens cut from castings are required in addition to or instead of separately cast specimens (Sections 12 and 15),

4.2.4 Whether repairs are permissible (18.1),

TABLE 2 Tensile Requirements^A (Inch-Pound Units)

NOTE 1—For purposes of determining conformance with this specification, each value for tensile strength and yield strength shall be rounded to the nearest 0.1 ksi and each value for elongation shall be rounded to the nearest 0.5 %, both in accordance with the rounding method of Practice E 29.

Alloy		Temper ^B	Tensile Strength, min, ksi	Yield Strength (0.2 % offset), min, ksi	Elongation in 2 in. or 4 x diameter, min, %	Typical Brinell Hard- ness, ^C 500 kgf, 10 mm
ANSI ^D	UNS					
201.0	A02010	T7	60.0	50.0	3.0	...
204.0	A02040	T4	45.0	28.0	6.0	...
242.0	A02420	O ^E	23.0	F	F	70
		T61	32.0	20.0	F	105
A242.0	A12420	T75	29.0	F	1.0	75
295.0	A02950	T4	29.0	13.0	6.0	60
		T6	32.0	20.0	3.0	75
		T62	36.0	28.0	F	95
		T7	29.0	16.0	3.0	70
319.0	A03190	F	23.0	13.0	1.5	70
		T5	25.0	F	F	80
		T6	31.0	20.0	1.5	80
328.0	A03280	F	25.0	14.0	1.0	60
		T6	34.0	21.0	1.0	80
355.0	A03550	T6	32.0	20.0	2.0	80
		T51	25.0	18.0	F	65
		T71	30.0	22.0	F	75
C355.0	A33550	T6	36.0	25.0	2.5	...
356.0	A03560	F	19.0	9.5	2.0	55
		T6	30.0	20.0	3.0	70
		T7	31.0	F	F	75
		T51	23.0	16.0	F	60
		T71	25.0	18.0	3.0	60
A356.0	A13560	T6	34.0	24.0	3.5	80
		T61	35.0	26.0	1.0	...
443.0	A04430	F	17.0	7.0	3.0	40
B443.0	A24430	F	17.0	6.0	3.0	40
512.0	A05120	F	17.0	10.0	...	50
514.0	A05140	F	22.0	9.0	6.0	50
520.0	A05200	T4	42.0	22.0	12.0	75
535.0	A05350	F	35.0	18.0	9.0	70
705.0	A07050	T5	30.0	17.0 ^G	5.0	65
707.0	A07070	T7	37.0	30.0 ^G	1.0	80
710.0 ^H	A07100	T5	32.0	20.0	2.0	75
712.0 ^H	A07120	T5	34.0	25.0 ^G	4.0	75
713.0	A07130	T5	32.0	22.0	3.0	75
771.0	A07710	T5	42.0	38.0	1.5	100
		T51	32.0	27.0	3.0	85
		T52	36.0	30.0	1.5	85
		T6	42.0	35.0	5.0	90
		T71	48.0	45.0	2.0	120
850.0	A08500	T5	16.0	F	5.0	45
851.0 ^H	A08510	T5	17.0	F	3.0	45
852.0 ^H	A08520	T5	24.0	18.0	F	60

^A If agreed upon between the manufacturer and the purchaser, other mechanical properties may be obtained by other heat treatments such as annealing, aging, or stress relieving.

^B Refer to ANSI H35.1 and/or H35.1M for description of tempers.

^C For information only, not required for acceptance.

^D ASTM alloy designations are recorded in Practice B 275.

^E Formerly designated as 222.0-T2 and 242.0-T21.

^F Not required.

^G Yield strength to be determined only when specified in the contract or purchase order.

^H 710.0 formerly A712.0, 712.0 formerly D712.0, 851.0 formerly A850.0, 852.0 formerly B850.0.

4.2.5 Whether inspection is required at the producer's works (Section 20),

4.2.6 Whether certification is required (23.1),

4.2.7 Whether surface requirements shall be checked against observational standards where such standards are established (21.1),

4.2.8 Whether liquid penetrant inspection is required (21.2),

4.2.9 Whether radiographic inspection is required (21.3),

and

4.2.10 Whether foundry control is required (Section 11).

4.2.11 Whether Practice B 660 applies and, if so, the levels of preservation, packaging and packing required (25.4).

5. Quality Assurance

5.1 Unless otherwise specified in the contract or purchase order, the producer shall be responsible for the performance of all inspections and test requirements specified herein. Unless disapproved by the purchaser, the producer may use his own or any other suitable facilities for the performance of the inspection and test requirements specified herein. The purchaser shall have the right to perform any of the inspections and tests set forth in this specification where such inspections are deemed necessary to confirm that the material conforms to prescribed requirements.

6. Manufacture

6.1 The responsibility of furnishing castings that can be laid out and machined to the finished dimensions within the permissible variations specified, as shown on the blueprints or drawings, shall rest with the producer, except where pattern equipment is furnished by the purchaser.

7. Chemical Composition

7.1 The castings shall conform to the chemical composition limits prescribed in **Table 1**. Conformance shall be determined by the producer by analyzing samples taken at the time the castings are poured, or samples taken from castings or tension test specimens representative of castings. If the producer has determined the chemical composition of the material during the course of manufacture, he shall not be required to sample and analyze the finished product.

8. Sampling

8.1 A sample for determining of chemical composition shall be taken to represent the following:

8.1.1 Not more than 2000 lb [1000 kg] of clean castings (gates and risers removed) or a single casting poured from one furnace.

8.1.2 Castings poured continuously from one furnace for not more than 8 consecutive hours.

8.2 Samples for determination of chemical composition shall be taken in accordance with one of the following methods:

8.2.1 *Samples for Chemical Analysis*— Samples for chemical analysis shall be in accordance with Practice E 88 except that the weight of a prepared sample shall be not less than 75 g.

8.2.2 *Samples for Spectrochemical and Other Methods of Analysis*— Sampling for spectrochemical analysis shall be in accordance with Practices E 716. Samples for other methods of analysis shall be suitable for the form of material being analyzed and the type of analytical methods used.

9. Methods for Determination of Chemical Composition

9.1 The determination of chemical composition shall be made in accordance with suitable chemical (Test Methods E 34) or spectrochemical (Test Methods E 607 and E 1251) methods. Other methods may be used only when no published ASTM method is available. In case of dispute, the method of analysis shall be agreed upon by the producer and the purchaser.

10. Material Requirements—Castings Produced for Governmental and Military Agencies

10.1 Unless otherwise specified, only aluminum alloy conforming to the requirements of Specification B 179 or producer's foundry scrap (identified as being made from alloy conforming to Specification B 179) shall be used in the remelting furnace from which molten metal is taken for pouring directly into castings. Additions of small amounts of modifiers and grain refining elements or alloys are permitted.

10.1.1 Pure materials, recycled materials, and master alloys may be used to make alloys conforming to this specification,

provided chemical analysis can be taken and adjusted to conform to **Table 1** prior to pouring any castings.

11. Foundry Control—Castings Produced for Governmental and/or Military Agencies

11.1 When specified, castings shall be produced under foundry control approved by the purchaser. Foundry control shall consist of examination of castings by radiographic or other approved methods for determining internal discontinuities until the gating, pouring, and other foundry practices have been established to produce castings meeting the quality standards furnished by the purchaser or agreed upon between the purchaser and the producer. When foundry practices have been so established, the production method shall not be significantly changed without demonstrating to the satisfaction of the purchaser that the change does not adversely affect the quality of the castings. Minor changes in pouring temperature of $\pm 50^{\circ}\text{F}$ [$\pm 28^{\circ}\text{C}$] from the established nominal temperature are permissible.

12. Tensile Properties

12.1 The separately cast test specimens representing the castings shall meet the mechanical properties prescribed in **Table 2**.

12.2 Although Alloys 705.0, 707.0, 712.0, and 713.0 are most frequently used in the naturally aged condition, by agreement between the producer and the purchaser, the castings may be artificially aged to the T5 temper. The producer and the purchaser may also agree to base the acceptance of castings on artificially aged test bars. The conditions of artificial aging shown in Practice B 917/B 917M shall be employed unless other conditions are accepted by mutual consent.

12.3 When specified, the tensile strength, yield strength, and elongation values of specimens cut from castings shall be not less than 75 % of the tensile and yield strength values and not less than 25 % of the elongation values specified in **Table 2** [**Table 3**]. The measurement of the elongation is not required for test specimens cut from castings if 25 % of the specified minimum elongation value published in **Table 2** [**Table 3**] is 0.5 % or less. If grade D quality castings as described in **Table 4** are specified, no tensile tests shall be specified nor tensile requirements be met on specimens cut from castings.

13. Workmanship, Finish, and Appearance

13.1 The finished castings shall be uniform in composition and free of blowholes, cracks, shrinks, and other discontinuities except as designated and agreed upon as acceptable by the purchaser.

14. Number of Tests and Retests

14.1 Unless otherwise agreed upon between the purchaser and producer, a minimum of two tension test specimens shall be separately cast and tested to represent the following:

14.1.1 Not more than 4000 lb [2000 kg] of clean castings (gates and risers removed) or a single casting poured from one furnace.

14.1.2 The castings poured continuously from one furnace in not more than eight consecutive hours.

TABLE 3 Tensile Requirements (SI Units)—[Metric]^A

NOTE 1—For purposes of determining conformance with this specification, each value for tensile strength and yield strength shall be rounded to the nearest 1 MPa and each value for elongation shall be rounded to the nearest 0.5 %, both in accordance with the rounding method of Practice E 29.

Alloy		Temper ^B	Tensile Strength, min, MPa ^C	Yield Strength (0.2 % offset), min, MPa ^C	Elongation in 5× diameter, min %	Typical Brinell Hardness, ^D 500 kgf, 10 mm
ANSI ^E	UNS					
201.0	A02010	T7	415	345	3.0	...
204.0	A02040	T4	310	195	6.0	...
242.0	A02420	O ^F	160	^G	^G	70
		T61	220	140	^G	105
A242.0	A12420	T75	200	^G	1.0	75
295.0	A02950	T4	200	90	6.0	60
		T6	220	140	3.0	75
		T62	250	195	^G	95
		T7	200	110	3.0	70
319.0	A03190	F	160	90	1.5	70
		T5	170	^G	^G	80
		T6	215	140	1.5	80
328.0	A03280	F	170	95	1.0	60
		T6	235	145	1.0	80
355.0	A03550	T6	220	140	2.0	80
		T51	170	125	^G	65
		T71	205	150	^G	75
C355.0	A33550	T6	250	170	2.5	...
356.0	A03560	F	130	65	2.0	55
		T6	205	140	3.0	70
		T7	215	^G	^G	75
		T51	160	110	^G	60
		T71	170	125	3.0	60
A356.0	A13560	T6	235	165	3.5	80
		T61	245	180	1.0	...
443.0	A04430	F	115	50	3.0	40
B443.0	A24430	F	115	40	3.0	40
512.0	A05120	F	115	70	...	50
514.0	A05140	F	150	60	6.0	50
520.0	A05200	T4	290	150	12.0	75
535.0	A05350	F	240	125	9.0	70
705.0	A07050	T5	205	115 ^H	5.0	65
707.0	A07070	T7	255	205 ^H	1.0	80
710.0 ^I	A07100	T5	220	140	2.0	75
712.0 ^I	A07120	T5	235	170 ^H	4.0	75
713.0	A07130	T5	220	150	3.0	75
771.0	A07710	T5	290	260	1.5	100
		T51	220	185	3.0	85
		T52	250	205	1.5	85
		T6	290	240	5.0	90
		T71	330	310	2.0	120
850.0	A08500	T5	110	^G	5.0	45
851.0 ^I	A08510	T5	115	^G	3.0	45
852.0 ^I	A08520	T5	165	125	^G	60

^A If agreed upon between the manufacturer and the purchaser, other mechanical properties may be obtained by other heat treatments such as annealing, aging, or stress relieving.

^B Temper designations:

F As fabricated.

O Annealed.

T1 Cooled from an elevated temperature shaping process and naturally aged to a substantially stable condition.

T4 Solution heat-treated and naturally aged to a substantially stable condition.

T5 Cooled from an elevated temperature shaping process and then artificially aged.

T6 Solution heat-treated and then artificially aged.

T7 Solution heat-treated and stabilized.

Additional digits, the first of which shall not be zero, may be added to designation T1 through T10 to indicate a variation in treatment that significantly alters the characteristics of the product.

^C For explanation of the SI unit "MPa" see Appendix X2.

^D For information only, not required for acceptance.

^E ASTM alloy designations are recorded in Practice B 275.

^F Formerly designated as 222.0-T2 and 242.0-T21.

^G Not required.

^H Yield strength to be determined only when specified in the contract or purchase order.

^I 710.0 formerly A712.0, 712.0 formerly D712.0, 851.0 formerly A850.0, 852.0 formerly B850.0.

TABLE 4 Discontinuity-Level Requirements for Aluminum Sand Castings (Reference Radiographs E 155)

Discontinuity	Radiograph	Section Thickness in. [mm]							
		Grade A ^A		Grade B		Grade C		Grade D	
		¼ [6.4]	¾ [19.0]	¼ [6.4]	¾ [19.0]	¼ [6.4]	¾ [19.0]	¼ [6.4]	¾ [19.0]
Gas holes	1.1	none		1	1	2	2	5	5
Gas porosity (round)	1.21	none		1	1	3	3	7	7
Gas porosity (elongated)	1.22	none		1	1 ^B	3	4	5	5 ^B
Shrinkage cavity	2.1	none		1		2	^B	3	^B
Shrinkage porosity or sponge	2.2	none		1	1	2	2	4	3
Foreign material (less dense material)	3.11	none		1	1	2	2	4	4
Foreign material (more dense material)	3.12	none		1	1	2	1	4	3
Segregation	3.2	none			none	none		none	none
Cracks	...	none		none	none	none		none	none
Cold shuts	...	none		none		none		none	none
Surface irregularity				not to exceed drawing tolerance			
Core shift				not to exceed drawing tolerance			

^A Caution should be exercised in requesting Grade A.

^B Not available.

14.2 When tensile properties from castings are to be determined, one per melt-heat combination shall be tested unless otherwise shown on the drawing or specified in the purchase order.

14.3 If any test specimen shows defective machining or flaws, it may be discarded; in which case the purchaser and the producer shall agree upon the selection of another specimen in its stead.

14.4 If the results of the tension tests do not conform to the requirements prescribed in Table 2 [Table 3]; the test bars representative of the castings may be retested in accordance with the replacement tests and retest provisions of Test Methods B 557 and B 557M, and the results of retests shall conform to the requirements as to mechanical properties specified in Table 2 [Table 3].

15. Specimen Preparation

15.1 The tension test specimens shall be cast to size in sand without chills in accordance with the dimensions shown in Fig. 1 [Fig. 2]. They shall not be machined prior to test except to adapt the grip ends in such a manner as to ensure axial loading.

15.2 The recommended method for casting tension test specimens is shown in Fig. 1 [Fig. 2].

15.3 When properties of castings are to be determined, tension test specimens shall be cut from the locations designated on the drawing, unless otherwise negotiated. If no locations are designated, one or more specimens shall be taken to include locations having significant variation in casting thickness, except that specimens shall not be taken from areas directly under risers. The tension test specimens shall be the standard 0.500-in. [12.5-mm] diameter specimens shown in Fig. 9 of Test Methods B 557 and B 557M or a round specimen of smaller size proportional to the standard specimen. In no case shall the dimensions of the smallest specimen be less than the following:

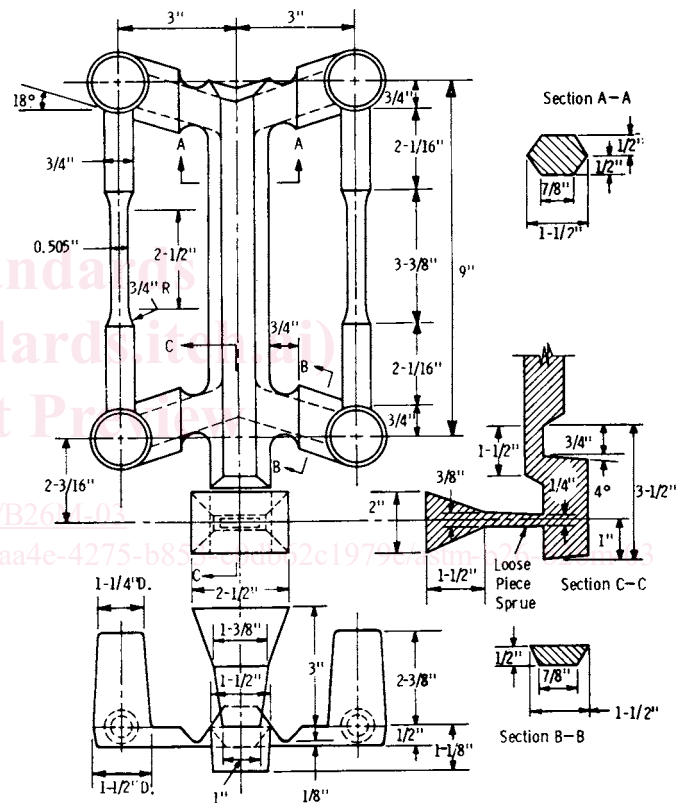

NOTE 1—1 in. = 25.4 mm.

FIG. 1 Tension Test Specimen Casting