

---

---

**Plastics — Film and sheeting —  
Determination of water vapour  
transmission rate —**

Part 3:

**Electrolytic detection sensor method**

iTeh STANDARD PREVIEW

*Plastiques — Film et feuille — Détermination du coefficient de  
transmission de vapeur d'eau —*

*Partie 3: Méthode utilisant un détecteur électrolytique*

[ISO 15106-3:2003](#)

<https://standards.iteh.ai/catalog/standards/sist/a7d09267-7c20-43e1-9db9-c2481aeab88d/iso-15106-3-2003>



**PDF disclaimer**

This PDF file may contain embedded typefaces. In accordance with Adobe's licensing policy, this file may be printed or viewed but shall not be edited unless the typefaces which are embedded are licensed to and installed on the computer performing the editing. In downloading this file, parties accept therein the responsibility of not infringing Adobe's licensing policy. The ISO Central Secretariat accepts no liability in this area.

Adobe is a trademark of Adobe Systems Incorporated.

Details of the software products used to create this PDF file can be found in the General Info relative to the file; the PDF-creation parameters were optimized for printing. Every care has been taken to ensure that the file is suitable for use by ISO member bodies. In the unlikely event that a problem relating to it is found, please inform the Central Secretariat at the address given below.

**iTeh STANDARD PREVIEW**  
**(standards.iteh.ai)**

[ISO 15106-3:2003](#)

<https://standards.iteh.ai/catalog/standards/sist/a7d09267-7c20-43e1-9db9-c2481aeab88d/iso-15106-3-2003>

© ISO 2003

All rights reserved. Unless otherwise specified, no part of this publication may be reproduced or utilized in any form or by any means, electronic or mechanical, including photocopying and microfilm, without permission in writing from either ISO at the address below or ISO's member body in the country of the requester.

ISO copyright office  
Case postale 56 • CH-1211 Geneva 20  
Tel. + 41 22 749 01 11  
Fax + 41 22 749 09 47  
E-mail [copyright@iso.org](mailto:copyright@iso.org)  
Web [www.iso.org](http://www.iso.org)

Published in Switzerland

## Contents

Page

Foreword.....	iv
1 Scope.....	1
2 Normative references .....	1
3 Term and definition.....	1
4 Principle .....	1
5 Test specimens .....	2
6 Conditioning .....	2
7 Apparatus .....	2
8 Test conditions.....	3
9 Procedure .....	4
10 Calculation.....	4
11 Test result .....	4
12 Precision .....	5
13 Test report .....	5
<b>Annex A (informative) Relationship between relative humidity and concentration of sulfuric acid solution .....</b>	<b>6</b>
	<a href="https://standards.iteh.ai/catalog/standards/sist/a7d09267-7c20-43e1-9db9-c2481aeab88d/iso-15106-3-2003">https://standards.iteh.ai/catalog/standards/sist/a7d09267-7c20-43e1-9db9-c2481aeab88d/iso-15106-3-2003</a>

## Foreword

ISO (the International Organization for Standardization) is a worldwide federation of national standards bodies (ISO member bodies). The work of preparing International Standards is normally carried out through ISO technical committees. Each member body interested in a subject for which a technical committee has been established has the right to be represented on that committee. International organizations, governmental and non-governmental, in liaison with ISO, also take part in the work. ISO collaborates closely with the International Electrotechnical Commission (IEC) on all matters of electrotechnical standardization.

International Standards are drafted in accordance with the rules given in the ISO/IEC Directives, Part 2.

The main task of technical committees is to prepare International Standards. Draft International Standards adopted by the technical committees are circulated to the member bodies for voting. Publication as an International Standard requires approval by at least 75 % of the member bodies casting a vote.

Attention is drawn to the possibility that some of the elements of this document may be the subject of patent rights. ISO shall not be held responsible for identifying any or all such patent rights.

ISO 15106-3 was prepared by Technical Committee ISO/TC 61, *Plastics*, Subcommittee SC 11, *Products*.

ISO 15106 consists of the following parts, under the general title *Plastics — Film and sheeting — Determination of water vapour transmission rate*:

— *Part 1: Humidity detection sensor method*

— *Part 2: Infrared detection sensor method* <https://standards.iteh.ai/catalog/standards/sist/a7d09267-7c20-43e1-9db9-c2481aeab88d/iso-15106-3-2003>

— *Part 3: Electrolytic detection sensor method*

# Plastics — Film and sheeting — Determination of water vapour transmission rate —

## Part 3: Electrolytic detection sensor method

### 1 Scope

This part of ISO 15106 specifies an instrumental method for determining the water vapour transmission rate of plastic film, plastic sheeting and multi-layer structures including plastics, using an electrolytic detection sensor.

NOTE The method provides rapid measurement over a wide range of water vapour transmission rates.

### 2 Normative references

The following referenced documents are indispensable for the application of this document. For dated references, only the edition cited applies. For undated references, the latest edition of the referenced document (including any amendments) applies.

ISO 2528:1995, *Sheet materials — Determination of water vapour transmission rate — Gravimetric (dish) method*

ISO 4593:1993, *Plastics — Film and sheeting — Determination of thickness by mechanical scanning*

### 3 Term and definition

For the purposes of this document, the following term and definition apply.

#### 3.1

##### **water vapour transmission rate**

the amount of water vapour transmitted through unit area of test specimen per unit time under specified conditions

NOTE Water vapour transmission rate is expressed in grams per square metre 24 hours [g/(m<sup>2</sup>·24 h)].

### 4 Principle

The gas transmission cell is designed in such a way that, with the test specimen inserted, it is divided into a dry chamber and a controlled-humidity chamber. The dry side of the specimen is swept by a flow of dry carrier gas, and water vapour permeating through the specimen from the controlled-humidity chamber is carried by the carrier gas into an electrolytic cell. This cell contains two spiral wire electrodes, coated with a thin layer of phosphorous pentoxide, mounted on the inside wall of a glass capillary. The carrier gas is passed through the capillary where the moisture it holds is quantitatively absorbed by the phosphorous pentoxide and decomposed electrolytically into hydrogen and oxygen by the application of a D.C. voltage of about 70 V to the electrodes. The mass of the moisture which permeates through the specimen and is decomposed per unit time is calculated from the electrolytic current required.

## 5 Test specimens

5.1 The specimens shall be representative of the material, be free from wrinkles, creases and pinholes, and have uniform thickness. Each specimen shall have a larger area than the transmission area of the cell used for the test, and shall be hermetically mounted.

5.2 Three specimens shall be used unless otherwise specified or agreed between the interested parties.

NOTE For some products, testing more than three specimens gives a more representative result.

5.3 Unless otherwise specified, determine the thickness of each specimen in accordance with ISO 4593 at three points that are equally spaced.

## 6 Conditioning

Condition the specimens at  $23\text{ °C} \pm 2\text{ °C}$  and a relative humidity of  $(50 \pm 10)\%$ . The period of conditioning shall be as stated in the relevant specification for the material.

## 7 Apparatus

7.1 An example of a suitable apparatus is shown in Figure 1. The apparatus includes a transmission cell with two chambers, a lower (dry) chamber and an upper (controlled-humidity) chamber between which a specimen is mounted, an electrolytic cell to determine the amount of water vapour transmitted, a flow meter, two drying tubes (containing e.g. molecular-sieve material) and a switch valve.

7.2 The transmission area shall be between  $5\text{ cm}^2$  and  $100\text{ cm}^2$ . The temperature of the transmission cell shall be kept within  $\pm 0,5\text{ °C}$  of the test temperature by means of a temperature controller.

7.3 The flow meter shall be capable of measuring flow rates from 5 ml to 100 ml per minute.

7.4 The drying tubes shall be capable of drying the carrier gas down to the detection limit of the electrolytic cell or lower.

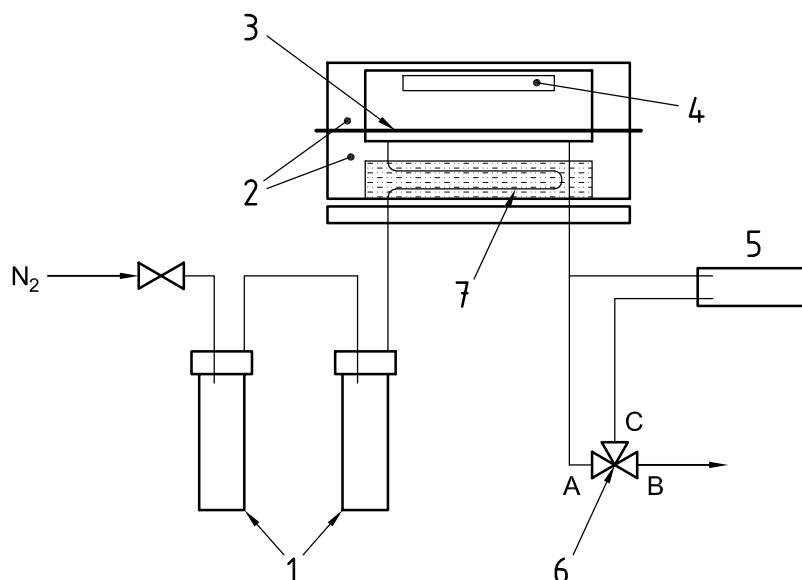

### Key

- 1 Drying tubes (containing e.g. a molecular sieve)
- 2 Two-chamber transmission cell (with thermostatted liquid flowing through both halves)
- 3 Specimen
- 4 Glass-fibre plate impregnated with sulfuric acid solution
- 5 Electrolytic cell
- 6 Switch valve
- 7 Copper tubing for carrier-gas supply (in thermostatted liquid to bring gas to test temperature)

Figure 1 — Example of water vapour transmission rate measuring apparatus with electrolytic sensor

## 8 Test conditions

The test conditions should preferably be chosen from those given in Table 1.

Table 1 — Choice of test conditions

Set of test conditions	Temperature °C	RH %
1	25 ± 0,5	90 ± 2
2	38 ± 0,5	90 ± 2
3	40 ± 0,5	90 ± 2
4	23 ± 0,5	85 ± 2
5	25 ± 0,5	75 ± 2

Test conditions other than these shall be agreed upon by the interested parties.

## 9 Procedure

9.1 Measure the water vapour transmission rate of each specimen as described in 9.2 to 9.7.

9.2 Place a glass-fibre plate impregnated with a suitable sulfuric acid solution in the upper chamber to produce a constant humidity level.

NOTE The relationship between relative humidity and the concentration of the sulfuric acid solution is shown in Annex A.

9.3 Place the specimen between the upper and lower chambers (see Figure 1), and close the transmission cell to give a gastight assembly.

9.4 With the switch valve positioned so that the carrier gas follows the path A-B, feed carrier gas through the drying tubes into the lower chamber.

NOTE The gas now bypasses the electrolytic cell and passes directly into the atmosphere. This prevents the humid air which enters the lower chamber when a specimen is put in place from being carried into the electrolytic cell and moistening it, invalidating the test results.

9.5 Apply a constant D.C. voltage of about 70 V to the electrolytic cell.

NOTE It is recommended that the electrolytic cell be kept permanently switched on, unless it is not going to be used for a long period.

9.6 After about 30 min, position the switch valve so that the carrier gas follows the path C-B and passes through the electrolytic cell. Monitor the current.

9.7 When the current remains constant, indicating that permeation has reached a steady state, record this value.

<https://standards.iteh.ai/catalog/standards/sist/a7d09267-7c20-43e1-9db9-c2481aeab88d/iso-15106-3-2003>

## 10 Calculation

Calculate the water vapour transmission rate of each test specimen using the following equation:

$$WVTR = \frac{I}{A} \times 8,067$$

where

WVTR is the water vapour transmission rate of the specimen, expressed in grams per square metre 24 hours [g/(m<sup>2</sup>·24 h)];

*A* is the transmission area, in square metres, of the test specimen;

*I* is the electrolytic current, in amperes;

8,076 is the instrument constant.

## 11 Test result

Calculate the test result as the arithmetic mean of the results obtained for each test specimen, rounding to the second place of decimals if the value is less than one, and to two significant figures if the value is greater than one.



## 12 Precision

The precision of this test method is not known because inter-laboratory data are not available. When inter-laboratory data are obtained, a precision statement will be added at the following revision.

## 13 Test report

The test report shall include the following information:

- a) a reference to this part of ISO 15106;
- b) the name of the apparatus used;
- c) the test conditions;
- d) all details necessary for identification of the sample tested;
- e) the method of preparation of the test specimens;
- f) the side of the test specimen which faced the supply of water vapour;
- g) the transmission area of the test specimen;
- h) the mean thickness of the specimen;
- i) the number of specimens tested;
- j) details of specimen conditioning;
- k) the test result; <https://standards.iteh.ai/catalog/standards/sist/a7d09267-7c20-43e1-9db9-c2481aeab88d/iso-15106-3-2003>
- l) the date of the test.