



Designation: D1665 – 98 (Reapproved 2003)

Standard Test Method for Engler Specific Viscosity of Tar Products¹

This standard is issued under the fixed designation D1665; the number immediately following the designation indicates the year of original adoption or, in the case of revision, the year of last revision. A number in parentheses indicates the year of last reapproval. A superscript epsilon (ϵ) indicates an editorial change since the last revision or reapproval.

1. Scope

1.1 This test method covers the determination of specific viscosity of tars and their fluid products. It does not determine absolute viscosity, but is an empirical flow test. Only by conforming strictly to requirements of the test method are reproducible results obtained.

1.2 *This standard does not purport to address all of the safety concerns, if any, associated with its use. It is the responsibility of the user of this standard to establish appropriate safety and health practices and determine the applicability of regulatory limitations prior to use.*

2. Referenced Documents

2.1 *ASTM Standards:*²

- D140 Practice for Sampling Bituminous Materials
- E1 Specification for ASTM Liquid-in-Glass Thermometers
- E11 Specification for Woven Wire Test Sieve Cloth and Test Sieves

3. Terminology

3.1 *Definition:*

3.1.1 *Engler specific viscosity*—the ratio obtained by dividing the time of flow, in s, of 50 mL of material using an Engler viscosimeter at a selected temperature by a factor representing the time of flow, in s, for an equal volume of water at 25°C. The usual temperatures for determination of specific viscosity of tar materials are 25°C, 40°C, 50°C, and 100°C, and generally the temperature is so selected that the specific viscosity is not more than 45.

4. Summary of Test Method

4.1 The time, in s, is measured for a fixed volume of liquid material to flow through an efflux tube under an accurately reproducible head and at a closely controlled temperature. The Engler specific viscosity is then calculated by dividing the

efflux time by the viscosimeter calibration factor as determined by making the same efflux measurement for water.

5. Significance and Use

5.1 This test method is useful in characterizing the consistency of tar and tar distillates by measuring their flow properties. It is applicable to materials that are readily liquid at temperatures up to 100°C.

6. Apparatus

6.1 *Engler Viscosimeter* as shown in Fig. 1, consisting of the following:

6.1.1 *Cup*—This is a gold-plated cylindrical brass vessel of 106.0 ± 1.0 mm, *A*, inside diameter, closed at the top by a double walled lid. To the rounded bottom is attached a metal-encased tapered platinum efflux tube 20.0 ± 0.1 mm, *H*, long with an inside diameter of 2.90 ± 0.02 mm, *E*, at the top and 2.80 ± 0.02 mm, *F*, at the bottom. The efflux tube shall project through and extend 3.0 ± 0.2 mm, *G*, below a jacket that surrounds the cup and shall have a bottom outside diameter, including its surrounding metal, of 4.5 ± 0.2 mm, *I*. Three metal measuring points, spaced equidistantly around the circumference of the cup, are fastened to the sides and extend inwardly approximately 7 mm, then turn up at a right angle and end in sharp points which are located 52.0 ± 0.5 mm, *D*, vertically above the lower end of the efflux tube and 25.0 ± 1.0 mm, *C*, above the lowest portion of the cylindrical sidewall of the cup. They serve both for indicating when the instrument is level and for measuring the charge of material, which is approximately 250 mL.

6.1.2 *Jacket*—The cup is surrounded by a jacket which holds water or other suitable liquid serving as a constant temperature bath. In the type illustrated, the jacket is provided with a thermometer clamp and stirring device. A tripod supports the apparatus and also carries a ring burner by means of which the bath is heated. Adjustable legs on the tripod serve to level the instrument. Other arrangements of outer baths, supports, and stirring devices are acceptable, especially when it is desired to use more than one standardized cup in a single bath.

6.1.3 *Stopper*—The efflux tube in the cup is closed or opened by the insertion or withdrawal of a tapered hardwood stopper which, to leave the tube open, can be suspended by its brass pin from the hook on the cover. The stopper shall be a

¹ This test method is under the jurisdiction of ASTM Committee D04 on Road and Paving Materials and is the direct responsibility of Subcommittee D04.43 on Specifications and Tests for Tar and Tar Products.

Current edition approved July 10, 2003. Published September 2003. Originally approved in 1959. Previous edition approved in 1998 as D1665 – 98. DOI: 10.1520/D1665-98R03.

² For referenced ASTM standards, visit the ASTM website, www.astm.org, or contact ASTM Customer Service at service@astm.org. For *Annual Book of ASTM Standards* volume information, refer to the standard's Document Summary page on the ASTM website.

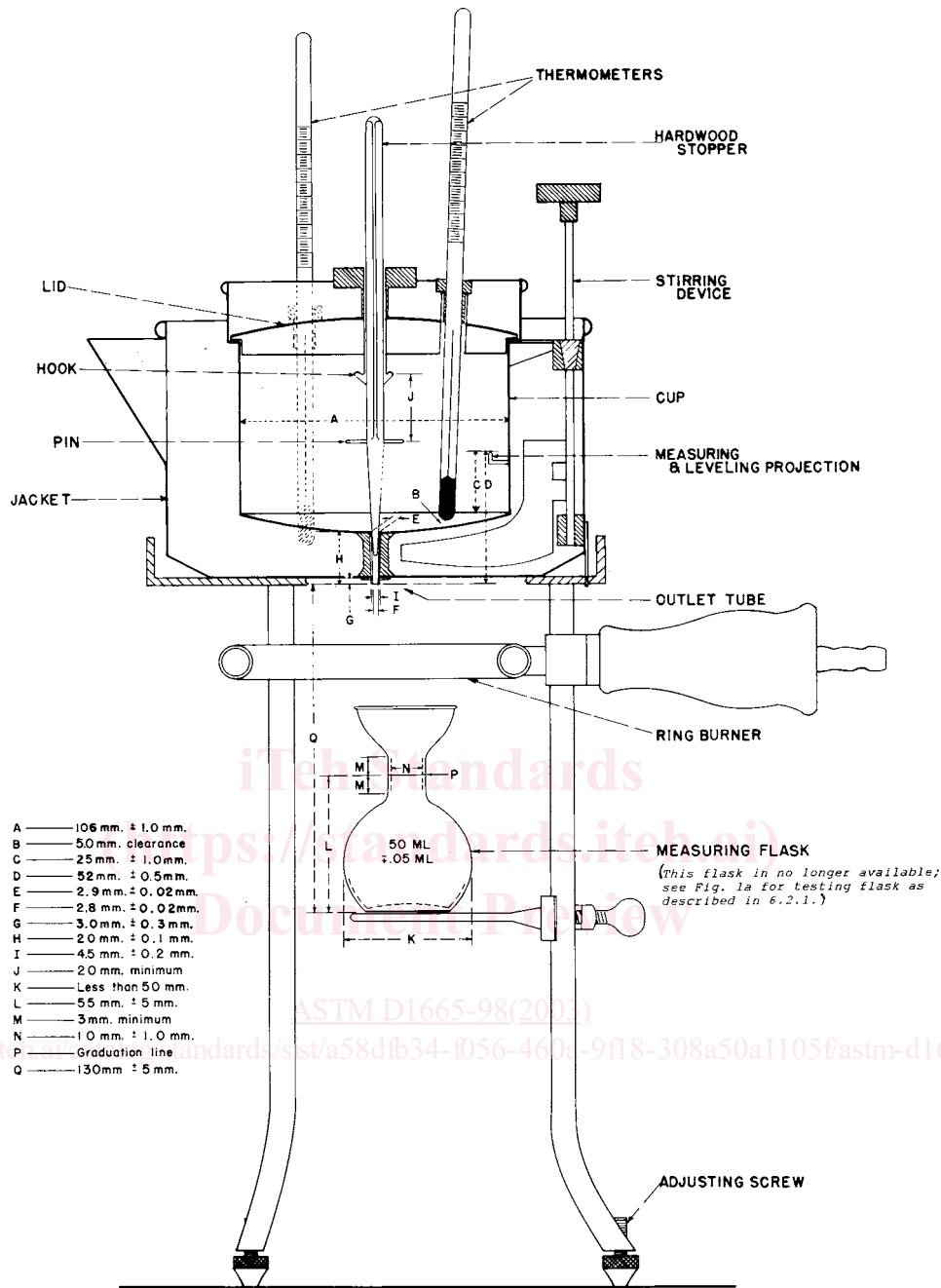

FIG. 1 Engler Viscosimeter

smooth, round, wooden rod 180 mm long and 8 mm in diameter, with a brass wire pin 20 mm and 1.83 mm in diameter long inserted diametrically through the rod at a point 50 mm from the lower end, and tapered uniformly below this pin to end in a circular plane 1.6 to 2.0 mm in diameter. Above the pin the rod shall be planed or grooved on four sides to a depth of 1 mm to prevent any possible restriction of air flow.

6.2 Receivers—Two types are required as follows:

6.2.1 Testing Flask—50 mL graduate calibrated at 20°C (see Fig. 2).

6.2.2 Calibration Flask—For standardization purposes there shall be available a Kohlrausch flask, Fig. 3, with top

enlarged above the graduation mark and calibrated to contain 200 ± 0.1 mL at 20°C.

6.3 Thermometers—ASTM Engler Viscosity Thermometers 23C, 24C, and 25C as required, and conforming to the requirements for these thermometers as specified in Specification E1.

6.4 Timer—Stop watch or other timing device graduated in divisions of 0.2 s or less, and accurate to within 0.1 % when tested over a 60-min period.

6.5 Strainer—300 mm ASTM sieve conforming to Specification E11.