



Designation: D3387 – 83 (Reapproved 2003)

Standard Test Method for Compaction and Shear Properties of Bituminous Mixtures by Means of the U.S. Corps of Engineers Gyrotory Testing Machine (GTM)¹

This standard is issued under the fixed designation D3387; the number immediately following the designation indicates the year of original adoption or, in the case of revision, the year of last revision. A number in parentheses indicates the year of last reapproval. A superscript epsilon (ϵ) indicates an editorial change since the last revision or reapproval.

1. Scope

1.1 This test method covers two separate modes of operation of the Gyrotory Testing Machine (GTM), namely: (1) GTM fixed roller mode; and (2) GTM oil-filled roller mode. The fixed roller mode of operation is employed in testing for compaction and strain indices only, while the oil-filled roller mode of operation is employed in testing for strength properties as well as compaction and strain indices. This test method is for use with mixtures containing asphalt cement, asphalt cut-back, asphalt emulsion, or tar and aggregate up to 1 in. (25.4 mm) maximum size in the 4-in. (101.6-mm) diameter specimen and 1.5 in. (38.1 mm) maximum size in the 6-in. (152.4-mm) diameter specimen.

1.2 *This standard does not purport to address all of the safety concerns, if any, associated with its use. It is the responsibility of the user of this standard to establish appropriate safety and health practices and determine the applicability of regulatory limitations prior to use.*

2. Referenced Documents

2.1 *ASTM Standards:*²

C136 Test Method for Sieve Analysis of Fine and Coarse Aggregates

C670 Practice for Preparing Precision and Bias Statements for Test Methods for Construction Materials

3. Terminology

3.1 *Definitions:*

3.1.1 *gyrograph*—a recording of shear strain experienced by the bituminous mixture during the compaction test (see Fig. 1).

¹ This test method is under the jurisdiction of ASTM Committee D04 on Road and Paving Materials and is the direct responsibility of Subcommittee D04.26 on Fundamental/Mechanistic Tests.

Current edition approved July 10, 2003. Published September 2003. Originally approved in 1974. Last previous edition approved in 1998 as D3387 – 83 (1996). DOI: 10.1520/D3387-83R03.

² For referenced ASTM standards, visit the ASTM website, www.astm.org, or contact ASTM Customer Service at service@astm.org. For *Annual Book of ASTM Standards* volume information, refer to the standard's Document Summary page on the ASTM website.

3.1.2 *gyrotory angle*—a measure of the magnitude of the gyrotory strain. Three pertinent angles are defined as follows:

3.1.2.1 Initial gyrotory angle or shear strain (machine setting) θ_0 (see Fig. 1),

3.1.2.2 Minimum gyrotory angle or shear strain (minimum gyrograph band width) θ_i (see Fig. 1), and

3.1.2.3 Maximum gyrotory angle or shear strain (maximum gyrograph band width) θ_{max} (see Fig. 1).

3.1.3 *gyrotory stability index* (GSI)—the ratio of the maximum gyrotory angle to the minimum gyrotory angle (see Fig. 1).

3.1.4 *gyrotory compactibility index* (GCI)—the ratio of the unit mass (total mix) at 30 revolutions of the GTM to the unit mass (total mix) at 60 revolutions of the GTM.

3.1.5 *gyrotory shear strength* (S_G)—the shear resistance of the specimen which is, among other things, a function of the imposed vertical pressure and degree of strain (see Annex A1).

3.1.6 *gyrotory shear factor* (GSF)—the ratio of the measured gyrotory shear strength to the approximate theoretical maximum induced shear stress, that is, a factor of safety type index with regard to failure in simple shear for the defined loading conditions.

4. Significance and Use

4.1 Either mode of operation (fixed roller or oil-filled roller) is intended to be used for guidance in selection of the optimum bitumen content and establishing unit mass requirements; additionally the oil-filled roller mode of operation is intended for use in arriving at a shear strength factor (referred to as gyrotory strength factor, GSF) with regard to shear under the load and strain conditions selected for the test. The procedure described here is for one selected degree of shear strain (in this case an initial gyrotory angle of 1°) and some selected vertical pressure (in this case the anticipated tire contact pressure). Attention is called to the fact that the gyrotory angle selected should relate to the anticipated pavement deflection. The 1° angle selected here should have wide application but should the pavement engineer select a different shear angle (such as a degree of shear strain), it should be so indicated in the report. It is essential that the vertical pressure correspond to the

Date _____

Operator _____

Sample Identification Dense Graded Crushed Stone (3/4-in. max)

Ram Pressure Gage Reading 202

Vertical Pressure on Specimen 120 psi

Aggregate Temp. 300 ± 5°F

Bitumen Temp. 270 ± 5°F

Compaction Temp. 250 ± 5°F

Dry Batch Mass 1247.6 g

Bitumen Mass 65.7 g

Bitumen Content 5.0 %
 * (Use 0.303 for 4-in. diameter specimen.)
 (Use 0.1347 for 6-in. diameter specimen.)

$$\text{Unit Mass} = \frac{\text{Mass, g}}{\text{Height, in.}} \times 0.303 \text{ lb/ft}^3$$

Initial Shear Strain, $\theta_o = 10/10$

Intermediate Shear Strain, $\theta_i = 14.3/10$

Maximum Shear Strain, $\theta_{max} = 15.0/10.0 = 1.75 \times 1.5^\circ = 2.6 \%$

Stability Index, $\theta_{max}/\theta_i = 15.0/14.3 = 1.05$

Compactibility Index = $\frac{30 \text{ rev } \gamma_{TM}}{60 \text{ rev } \gamma_{TM}} = 0.989$

Attach Gyrograph Below

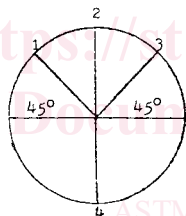

Roller Position

γ_{TM} = Unit mass total mix
 γ_{AO} = Unit mass aggregate only
 $\gamma_{AO} = \gamma_{TM} \times \text{percent aggregate}$

ASTM D3387-83(2003)

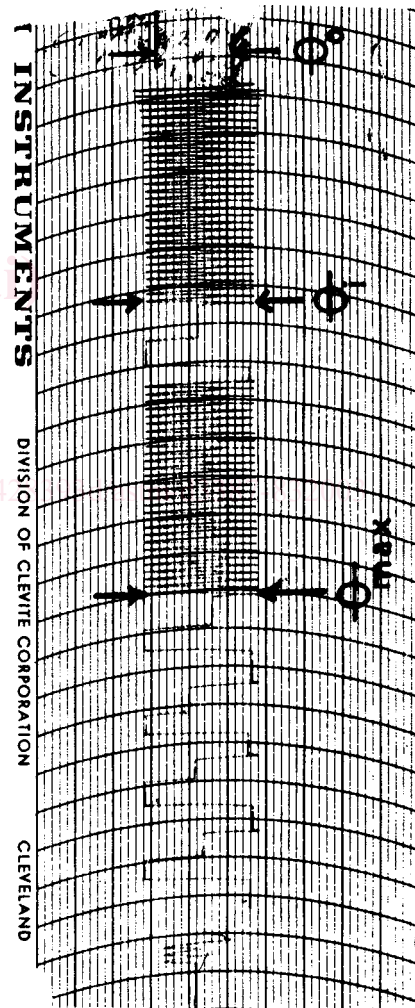

| Rev. | Roller Pressure, psi | | | | Temperature, °F | Unit Mass, lb/ft ³ | |
|----------|----------------------|-------|-------|-------|-----------------|-------------------------------|----------------|
| | 1 | 3 | 4 | Avg | | Total Mix | Aggregate only |
| 29 to 30 | 22 | 20 | 20 | 21 | 250 | 149.4 | 141.9 |
| 59 to 60 | 19 | 18 | 19 | 19 | 250 | 151.1 | 143.5 |
| | 2.635 | 2.634 | 2.633 | 2.634 | | | |

FIG. 1 GTM Compaction and Shear Test

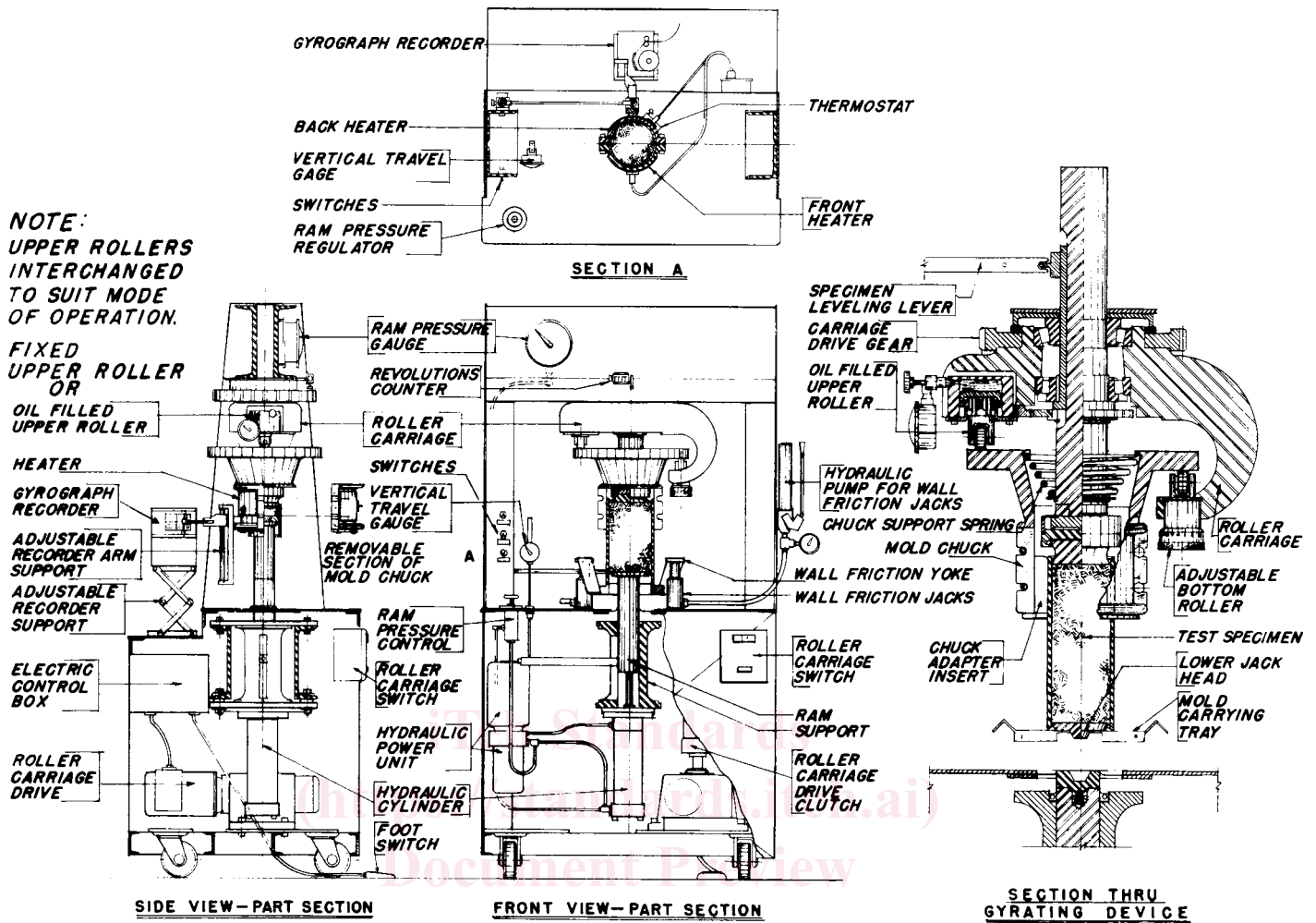

FIG. 2 Gyrotary Testing Machine

ASTM D3387-83(2003)

<https://standards.iteh.ai/catalog/standards/sist/4119e852-77ac-4dd8-a80c-b6dce428393d/astm-d3387-832003>

maximum anticipated tire contact pressure, since the theoretical stress for compaction and maximum induced shear used in determining the compaction requirements and the gyrotary strength factor (GSF) is based on the concept of employing realistic loads for the test.

4.2 The gyrotary strength factor (GSF) must be interpreted with due recognition of the use of the somewhat arbitrarily selected degree of strain and the assumption of plane maximum shear (the unit contact pressure divided by π) for a strip load on a homogeneous elastically isotropic mass.

4.3 The use of this method for guidance in the selection of the optimum bitumen content is limited to mixtures that are susceptible to the development of excess pore pressure when the voids become overfilled with bitumen. (This restriction does not apply to the gyrotary strength factor, GSF.) A gyrotary stability index (GSI), in excess of unity, indicates a progressive increase in plasticity during densification. An increase in this index indicates an excessive bitumen content for the compaction pressure employed and foretells instability of the bituminous mixture for the loading employed. A reduction in oil-filled roller pressure during the compaction process likewise indicates loss of stability because of overfilled voids; this phenomenon also serves as an indicator of maximum allowable

bitumen content as does the widening of the gyrograph which gives a stability index in excess of unity.

4.4 The gyrotary compactibility index (GCI) is an indicator of the compactibility of the mix. The closer this index approaches unity, the easier the mix is to compact.

5. Apparatus

5.1 *Gyrotary Testing Machine (GTM) and Appurtenances*—The primary equipment for this test is the Gyrotary Testing Machine (GTM)³ and appurtenances. Fig. 2 is an assembly drawing of the machine (and appurtenant equipment) indicating essential features, including the wall friction apparatus and a schematic of the gyrating mechanism. The fixed upper roller and the oil-filled upper roller are interchangeable; the roller being selected to fit the mode of operation of the GTM.

5.2 *Ovens*—Ventilated ovens shall be provided for heating aggregates, bituminous material, and specimen molds and for curing cut-back mixes and emulsion mixes. It is recommended

³ A novel mechanization of the original Texas gyrotary principle. This machine is manufactured by Engineering Developments Co., Inc. of Vicksburg, MI 39180, under letters Patent Nos. 2972249 and 3478572.

Date _____

Operator _____

Compaction 120 psi, 1°, 60 Rev.

Sample Identification Dense Graded Crushed Stone (3/4-in. max)

$\tau_{max} = \text{Vertical Pressure}/\pi = 120/3.14 = 38.2 \text{ psi}$ Machine Correction to $S_G = -10 \text{ psi}$

$\theta_o = 10/10 = 1.0^\circ = 1^\circ 0'$; $\tan \theta_o = 0.0175$

| Bitumen Content, % | Vertical Pressure Gage Reading, psi | Total Vertical Pressure, psi | Specimen Height, h, in. | | | | Roller Pressure Gage Reading, p, psi | | | |
|--------------------|-------------------------------------|------------------------------|-------------------------|-------|-------|------|--------------------------------------|----|----|-----|
| | | | 1 | 3 | 4 | Avg | 1 | 3 | 4 | Avg |
| 4.5 | 202 | 120 | 2.648 | 2.640 | 2.642 | 2.64 | 21 | 18 | 21 | 20 |
| 5.0 | 202 | 120 | 2.635 | 2.634 | 2.633 | 2.63 | 19 | 18 | 19 | 19 |
| 5.5 | 202 | 120 | 2.606 | 2.604 | 2.606 | 2.61 | 13 | 14 | 14 | 14 |

| θ_{max} , deg | θ_{max}/θ_o | Wall Friction Gage Reading, psi | Wall Friction 3.82 F or 2.55 F ^A | Total Vertical Load, V, lb | b h · tan θ_o | V · b | 90.0 p or 50.0 p ^A | 28.26 h or 12.65 h ^A | Shear, S _G , psi | | GSF S _G /τ _{max} |
|----------------------|-------------------------|---------------------------------|---|----------------------------|----------------------|-------|-------------------------------|---------------------------------|-----------------------------|-----------|--------------------------------------|
| | | | | | | | | | Uncorrected | Corrected | |
| 1.42 | 1.42 | 60 | 230 | 1507 | 0.046 | 69 | 1800 | 33 | 71 | 61 | 1.6 |
| 1.50 | 1.50 | 100 | 434 | 1507 | 0.046 | 69 | 1710 | 33 | 61 | 51 | 1.3 |
| 1.68 | 1.68 | 120 | 536 | 1507 | 0.046 | 69 | 1260 | 33 | 40 | 30 | 0.8 |

^A Select term to match applicable formula.

TM Model 4C

4-in. diameter specimen

$$S_G = \frac{50 p - 2.55 F + V \cdot b}{12.56 h} \left(\frac{\theta_{max}}{\theta_o} \right)$$

GTM Model 6B-4C

4-in. diameter specimen

$$S_G = \frac{90 p - 2.55 F + V \cdot b}{12.56 h} \left(\frac{\theta_{max}}{\theta_o} \right)$$

6-in. diameter specimen

$$S_G = \frac{90 p - 3.82 F + V \cdot b}{28.26 h} \left(\frac{\theta_{max}}{\theta_o} \right)$$

FIG. 3 GTM Shear Test

that the heating units be thermostatically controlled so as to maintain the required temperature within 5°F (2.8°C).

5.3 *Balances*, one having a capacity of 5 kg or more, sensitive to 1.0 g; and one having a capacity of 2 kg, sensitive to 0.1 g.

5.4 *Thermometers*—Armored glass or dial-type thermometers with metal stems are recommended. A range from 50 to 400°F (9.9 to 20.4°C) with sensitivity of 5°F (2.8°C) is required.

5.5 *Spacer Blocks*, two metal spacer blocks for use in zeroing the specimen height measuring equipment. These shall all be of 2-in. (50.8-mm) diameter with one each of the following lengths: 2.50 ± 0.005 in. (63.50 ± 0.013 mm) and 3.75 ± 0.005 in. (95.25 ± 0.013 mm).

5.6 *Miscellaneous Apparatus*—Trowels, spatulas, scoops, gloves, rubber gloves, metal pans, 4-in. (101.6-mm) diameter paper disks, and 6-in. (152.4-mm) diameter paper disks.

6. Test Specimens

6.1 *Selection of Bitumen Content for Specimens*—Conduct laboratory tests for one specimen each at a minimum of three bitumen contents, one above, one below, and one at the estimated optimum content (see **Note 1**). The incremental change of bitumen content should generally be 0.5 %. For

extremely critical mixes, lower the incremental change of bitumen content to 0.3 % and for highly absorptive aggregates, increase the incremental change of bitumen content to 1.0 %. Tests on additional bitumen contents should be conducted as necessary when check tests are needed.

6.2 *Preparation of Aggregates*—In accordance with Test Method **C136**, obtain a sieve analysis on the fine and coarse aggregate (aggregate shall be separated by means of a No. 4 (4.75-mm) sieve). Separate the aggregate into the various size fractions necessary for accurately recombining into test mixtures conforming to specified grading requirements.

6.3 *Preparation of Mixtures*—Combine the moisture-free aggregates into batches sufficiently large to make specimens approximately 2.50 in. (63.5 mm) long in the 4-in. (101.6-mm) diameter mold and 3.75 in. (95.3 mm) long in the 6-in. (152.4-mm) diameter mold. For normal aggregates, this will require approximately 1200 g for the 4-in. (101.6-mm) diameter specimens and approximately 4050 g for the 6-in. (152.4-mm) diameter specimens. Heat the aggregate to the proper mixing temperature; then weigh the required amount of bitumen at the proper temperature into the aggregate mixture. Mixing of the aggregate and bitumen shall be as thorough and rapid as possible; mechanical mixing is recommended.

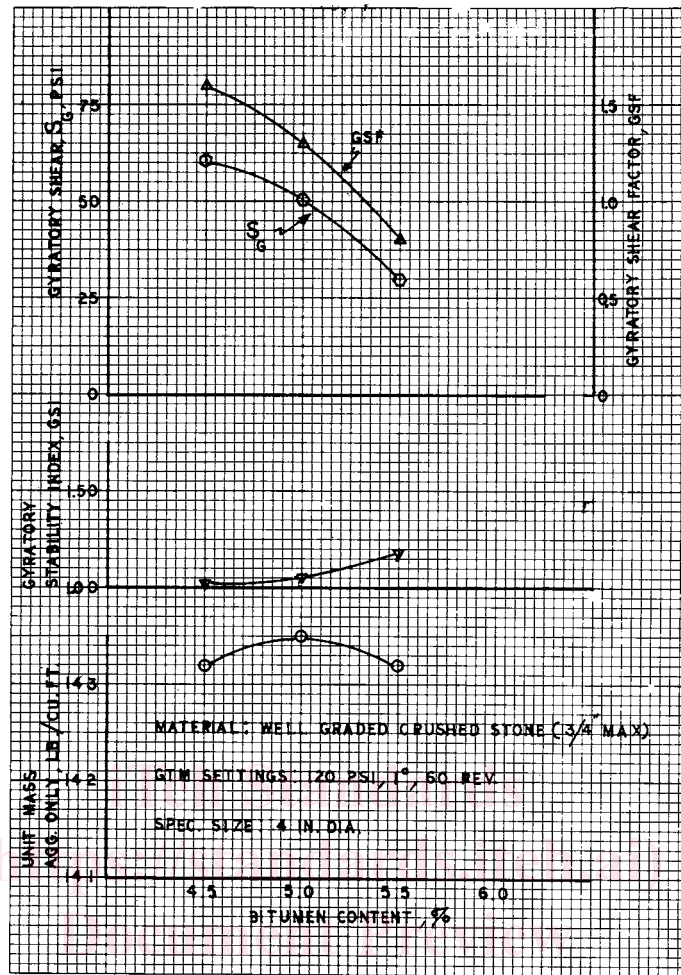

FIG. 4 Compaction and Shear Properties vs. Bitumen Content

ASTM D3387-83(2003)

NOTE 1—A first approximation of the optimum amount of bitumen for the aggregate may be determined by any method commonly employed by the laboratory. A method that has been found suitable in some laboratories is the centerfuge kerosene equivalent method.⁴

6.3.1 For mixes employing penetration/viscosity grades of asphalt, the temperature of the aggregate and asphalt at the time of mixing should correspond to the temperatures anticipated to be used at the plant during manufacture of the paving mix. These temperatures will generally be somewhere in the range of 250 to 325°F (121 to 149°C). Once the mixing temperature is selected, it should be so controlled that the viscosity of the bitumen will not vary more than ±50 cSt during the mixing process.

6.3.2 For tar mixtures, the temperature of the aggregate and tar at the time of mixing should correspond to the temperatures to be used at the plant during manufacture of the paving mix. This temperature will generally not exceed 225°F (107°C). Once the mixing temperature is specified, it should be so controlled that the viscosity of the tar will not vary more than ±5 Engler specific viscosity during the mixing process.

6.3.3 For mixtures employing liquid asphalts (cut backs or emulsions), the asphalt need not be heated but the aggregate

should be dried to constant weight at 221 to 230°F (105 to 110°C). The liquid asphalt should be combined with the aggregate at room temperature. Following mixing, cure the loose mixture in a ventilated oven maintained at 221 to 230°F (105 to 110°C) for at least 12 h prior to compaction at this temperature. The mix may be stirred occasionally during curing to accelerate loss of volatiles.

6.4 *Size of Specimens*—The 4-in. (101.6-mm) diameter specimens shall be approximately 2.50 in. (63.5 mm) long. The 6-in. (152.4-mm) diameter specimens shall be approximately 3.75 in. (95.3 mm) long.

7. Calibration

7.1 See Annex A2.

8. Procedure

8.1 *General*—The GTM-fixed roller is employed when the compaction test only is required. The GTM oil-filled roller is employed when both the compaction test and the shear test are required. The oil-filled roller procedure is accomplished in sequential steps including the compaction test, shear test, and wall friction test as outlined in this section. (The procedure for determining the machine correction for S_G is presented in Annex A2.) When using the fixed roller, inapplicable portions of the following instructions are ignored.

⁴ California Highways and Public Works, Vol 20, No. 7, July 1942, pp. 14-17.

8.2 *Compaction or Compaction and Shear Test*—Fig. 1 and Fig. 3 illustrate data sheets which are suitable for recording and calculating compaction or compaction and shear test results and for displaying the gyrograph (shear strain) recording. The gyratory strain angles θ_o , θ_i , and θ_{max} are indicated on the gyrograph displayed in Fig. 1. For this test, set the initial gyratory angle, θ_o , at 1° . Roller positions 2 and 4 (Fig. 1) are used in setting the initial gyratory angle, θ_o . A trial batch of mix is used in making the initial gyratory angle adjustment. Make certain that the specimen molds are thoroughly clean and free of defects. Excessive wear or grooving in the molds in the area of contact with the upper and lower plates will have an adverse effect upon the compaction as well as the gyrograph (shear strain) recording. Instructions for the compaction temperatures for the laboratory specimens are presented in 6.3.1 through 6.3.3. Set the GTM heater at 140°F (60°C) at least 15 min before starting the compaction test. Preheat the mold and base plate at 140°F (60°C). Place paper disks in the bottom of the mold and on top of the loose mix to prevent the bitumen from adhering to the end plates. Place the entire batch in the mold avoiding hand troweling or tamping as it is desired that the compaction process be completely mechanically controlled in order to attain the highest degree of precision and reproducibility. Use the mold-carrying tray to load the mold containing the mixture into the machine having first placed the wall friction yoke in position when employing the oil-filled roller mode of operation. Raise the ram and use a vertical pressure just sufficient to retain the specimen while the front of the mold chuck is tightened securely in position. When the mold chuck is securely tightened, increase the vertical pressure to the full compaction test pressure. Now bring the gyrograph recorder pin into contact and actuate the roller carriage and continue until 29 revolutions have been applied. At the completion of 29 revolutions, stop the carriage and record the specimen height and roller pressure readings (when required) at three positions 1, 3, and 4 (29 to 30 revolutions), as indicated in Fig. 1, thus completing 30 revolutions. Continue to apply additional revolutions until a total of 59 is reached. Again record height and roller pressure readings (when required) at three positions 1, 3, and 4 (59 to 60 revolutions) as indicated in Fig. 1, thus completing 60 revolutions. (Specimen height and roller-pressure reading may be taken at more frequent intervals of revolutions when more detailed delineation of these parameters is desired.)

8.3 *Wall Friction Test* (applicable when employing oil-filled roller mode of operation)—Immediately following the compaction and shear test, lower the vertical ram slightly so as to relieve the pressure on the bottom roller. Lower the bottom roller a sufficient number of turns to ensure that it will be out of contact with the mold chuck. (Keep account of the exact number of turns so that the roller can be again reset to exactly the same position.) Reapply the compaction pressure to the ram and cycle the roller carriage several times in order to level the specimen. With the compaction pressure still acting on the specimen, loosen the mold chuck bolts and remove the front section of the chuck so that the specimen mold is no longer restrained by the chuck. Install the two wall friction apparatus jacks beneath the wall friction yoke as illustrated in the

assembly drawing, Fig. 2. With the vertical load acting on the specimen, the force required to overcome wall friction and move the mold with respect to the specimen shall be determined by observing the pressure gage of the jack while actuating the jack. The pressure reading will be found to increase with each thrust of the jack until there is sufficient force to move the mold with respect to the specimen. The pressure reading will then stabilize to about the same value after each thrust of the jack. The reading of the wall friction gage shall be recorded in the space provided as illustrated in Fig. 3. Immediately after completion of the wall friction test, the test specimen should be removed from the GTM and the lower roller brought back to the 1° setting so that the machine is ready for the next test specimen.

9. Calculations

9.1 *Calculations for Compaction*—Calculate the following compaction properties for each specimen, as illustrated in Fig. 1: (1) unit mass, total mix; (2) unit mass, aggregate only; and (3) gyratory compactability index (GCI).

9.2 *Calculations for Shear*—Calculate the following gyratory shear properties (when applicable) as illustrated in Fig. 1 and Fig. 3: (1) gyratory stability index (GSI); (2) gyratory shear (S_G); and (3) gyratory shear factor (GSF).

10. Graphical Presentation

10.1 For convenience of analysis, the parameters calculated in Section 9 may be plotted against bitumen content. The graphs may be to any convenient arithmetic scales as illustrated in Fig. 4.

11. Report

11.1 The report shall include the following parameters for each specimen tested using either the fixed roller or the oil-filled roller mode of operation:

- 11.1.1 Mixing temperature,
- 11.1.2 Viscosity of bitumen at mixing temperature (give range),
- 11.1.3 Compacting temperature,
- 11.1.4 Viscosity of bitumen at compacting temperature (give range),
- 11.1.5 Initial gyratory angle,
- 11.1.6 Vertical pressure,
- 11.1.7 Number of revolutions,
- 11.1.8 Unit mass total mix,
- 11.1.9 Unit mass aggregate only,
- 11.1.10 Gyratory stability index (GSI), and
- 11.1.11 Gyratory compactability index (GCI).

11.2 In addition to the parameters in 11.1, the report shall include the following parameters for each specimen tested using the oilfilled roller mode of operation:

- 11.2.1 Gyratory shear strength (S_G), and
- 11.2.2 Gyratory strength factor (GSF).

12. Precision and Bias

12.1 Statistical data available at this time are limited to a series of within-laboratory tests by the U.S. Army Corps of Engineers Waterways Experiment Station. Tests were conducted on one high quality hot mix bituminous concrete