



Designation: E 8 – 03

An American National Standard
American Association State
Highway and Transportation Officials Standard
AASHTO No.: T68

Standard Test Methods for Tension Testing of Metallic Materials¹

This standard is issued under the fixed designation E 8; the number immediately following the designation indicates the year of original adoption or, in the case of revision, the year of last revision. A number in parentheses indicates the year of last reapproval. A superscript epsilon (ϵ) indicates an editorial change since the last revision or reapproval.

This standard has been approved for use by agencies of the Department of Defense.

1. Scope*

1.1 These test methods cover the tension testing of metallic materials in any form at room temperature, specifically, the methods of determination of yield strength, yield point elongation, tensile strength, elongation, and reduction of area.

NOTE 1—A complete metric companion to Test Methods E 8 has been developed, therefore, no metric equivalents are shown in these test methods. Committee E28 was granted an exception in 1997 by the Committee on Standards to maintain E8 and E8M as separate companion standards rather than combining standards as recommended by the Form and Style Manual.

NOTE 2—Gage lengths in these test methods are required to be 4D for most round specimens. Test specimens made from powder metallurgy (P/M) materials are exempt from this requirement by industry-wide agreement to keep the pressing of the material to a specific projected area and density.

NOTE 3—Exceptions to the provisions of these test methods may need to be made in individual specifications or test methods for a particular material. For examples, see Test Methods and Definitions A 370 and Test Methods B 557.

NOTE 4—Room temperature shall be considered to be 50 to 100°F unless otherwise specified.

1.2 *This standard does not purport to address all of the safety concerns, if any, associated with its use. It is the responsibility of the user of this standard to establish appropriate safety and health practices and determine the applicability of regulatory limitations prior to use.*

2. Referenced Documents

2.1 ASTM Standards:

A 356/A 356M Specification for Steel Castings, Carbon, Low Alloy, and Stainless Steel, Heavy-Walled for Steam Turbines²

A 370 Test Methods and Definitions for Mechanical Testing of Steel Products³

¹ These test methods are under the jurisdiction of ASTM Committee E28 on Mechanical Testing and are the direct responsibility of Subcommittee E28.04 on Uniaxial Testing.

Current edition approved July 10, 2003. Published September 2003. Originally approved in 1924. Last previous edition approved 2000 as E 8 – 01 ϵ 2.

² Annual Book of ASTM Standards, Vol 01.02.

³ Annual Book of ASTM Standards, Vol 01.03.

B 557 Test Methods of Tension Testing Wrought and Cast Aluminum- and Magnesium-Alloy Products⁴

E 4 Practices for Force Verification of Testing Machines⁵

E 6 Terminology Relating to Methods of Mechanical Testing⁵

E 8M Test Methods for Tension Testing of Metallic Materials [Metric]⁵

E 29 Practice for Using Significant Digits in Test Data to Determine Conformance with Specifications⁶

E 83 Practice for Verification and Classification of Extensometers⁵

E 208 Test Method for Conducting Drop-Weight Test to Determine Nil-Ductility Transition Temperature of Ferritic Steels⁵

E 345 Test Methods of Tension Testing of Metallic Foil⁵

E 691 Practice for Conducting an Interlaboratory Study to Determine the Precision of a Test Method⁶

E 1012 Practice for Verification of Specimen Alignment Under Tensile Loading⁵

3. Terminology

3.1 *Definitions*—The definitions of terms relating to tension testing appearing in Terminology E 6 shall be considered as applying to the terms used in these test methods of tension testing. Additional terms being defined are as follows:

3.1.1 *discontinuous yielding*—in a uniaxial test, a hesitation or fluctuation of force observed at the onset of plastic deformation, due to localized yielding. (The stress-strain curve need not appear to be discontinuous.)

3.1.2 *lower yield strength, LYS* [FL^{-2}]—in a uniaxial test, the minimum stress recorded during discontinuous yielding, ignoring transient effects.

3.1.3 *upper yield strength, UYS* [FL^{-2}]—in a uniaxial test, the first stress maximum (stress at first zero slope) associated with discontinuous yielding at or near the onset of plastic deformation.

3.1.4 *yield point elongation, YPE*—in a uniaxial test, the strain (expressed in percent) separating the stress-strain curve's

⁴ Annual Book of ASTM Standards, Vol 02.02.

⁵ Annual Book of ASTM Standards, Vol 03.01.

⁶ Annual Book of ASTM Standards, Vol 14.02.

*A Summary of Changes section appears at the end of this standard.

first point of zero slope from the point of transition from discontinuous yielding to uniform strain hardening. If the transition occurs over a range of strain, the YPE end point is the intersection between (a) a horizontal line drawn tangent to the curve at the last zero slope and (b) a line drawn tangent to the strain hardening portion of the stress-strain curve at the point of inflection. If there is no point at or near the onset of yielding at which the slope reaches zero, the material has 0 % YPE.

3.1.5 *uniform elongation, El_u , [%]*—the elongation determined at the maximum force sustained by the test piece just prior to necking or fracture, or both.

3.1.5.1 *Discussion*—Uniform elongation includes both elastic and plastic elongation.

4. Significance and Use

4.1 Tension tests provide information on the strength and ductility of materials under uniaxial tensile stresses. This information may be useful in comparisons of materials, alloy development, quality control, and design under certain circumstances.

4.2 The results of tension tests of specimens machined to standardized dimensions from selected portions of a part or material may not totally represent the strength and ductility properties of the entire end product or its in-service behavior in different environments.

4.3 These test methods are considered satisfactory for acceptance testing of commercial shipments. The test methods have been used extensively in the trade for this purpose.

5. Apparatus

5.1 *Testing Machines*—Machines used for tension testing shall conform to the requirements of Practices E 4. The forces used in determining tensile strength and yield strength shall be within the verified force application range of the testing machine as defined in Practices E 4.

5.2 Gripping Devices:

5.2.1 *General*—Various types of gripping devices may be used to transmit the measured force applied by the testing machine to the test specimens. To ensure axial tensile stress within the gage length, the axis of the test specimen should coincide with the center line of the heads of the testing machine. Any departure from this requirement may introduce bending stresses that are not included in the usual stress computation (force divided by cross-sectional area).

NOTE 5—The effect of this eccentric force application may be illustrated by calculating the bending moment and stress thus added. For a standard 1/2-in. diameter specimen, the stress increase is 1.5 percentage points for each 0.001 in. of eccentricity. This error increases to 2.24 percentage points/0.001 in. for a 0.350-in. diameter specimen and to 3.17 percentage points/0.001 in. for a 0.250-in. diameter specimen.

NOTE 6—Alignment methods are given in Practice E 1012.

5.2.2 *Wedge Grips*—Testing machines usually are equipped with wedge grips. These wedge grips generally furnish a satisfactory means of gripping long specimens of ductile metal and flat plate test specimens such as those shown in Fig. 1. If, however, for any reason, one grip of a pair advances farther than the other as the grips tighten, an undesirable bending stress may be introduced. When liners are used behind the

wedges, they must be of the same thickness and their faces must be flat and parallel. For best results, the wedges should be supported over their entire lengths by the heads of the testing machine. This requires that liners of several thicknesses be available to cover the range of specimen thickness. For proper gripping, it is desirable that the entire length of the serrated face of each wedge be in contact with the specimen. Proper alignment of wedge grips and liners is illustrated in Fig. 2. For short specimens and for specimens of many materials it is generally necessary to use machined test specimens and to use a special means of gripping to ensure that the specimens, when under load, shall be as nearly as possible in uniformly distributed pure axial tension (see 5.2.3, 5.2.4, and 5.2.5).

5.2.3 *Grips for Threaded and Shouldered Specimens and Brittle Materials*—A schematic diagram of a gripping device for threaded-end specimens is shown in Fig. 3, while Fig. 4 shows a device for gripping specimens with shouldered ends. Both of these gripping devices should be attached to the heads of the testing machine through properly lubricated spherical-seated bearings. The distance between spherical bearings should be as great as feasible.

5.2.4 *Grips for Sheet Materials*—The self-adjusting grips shown in Fig. 5 have proven satisfactory for testing sheet materials that cannot be tested satisfactorily in the usual type of wedge grips.

5.2.5 *Grips for Wire*—Grips of either the wedge or snubbing types as shown in Fig. 5 and Fig. 6 or flat wedge grips may be used.

5.3 *Dimension-Measuring Devices*—Micrometers and other devices used for measuring linear dimensions shall be accurate and precise to at least one half the smallest unit to which the individual dimension is required to be measured.

5.4 *Extensometers*—Extensometers used in tension testing shall conform to the requirements of Practice E 83 for the classifications specified by the procedure section of this test method. Extensometers shall be used and verified to include the strains corresponding to the yield strength and elongation at fracture (if determined).

5.4.1 Extensometers with gage lengths equal to or shorter than the nominal gage length of the specimen (dimension shown as “G-Gage Length” in the accompanying figures) may be used to determine the yield behavior. For specimens without a reduced section (for example, full cross sectional area specimens of wire, rod, or bar), the extensometer gage length for the determination of yield behavior shall not exceed 80 % of the distance between grips. For measuring elongation at fracture with an appropriate extensometer, the gage length of the extensometer shall be equal to the nominal gage length required for the specimen being tested.

6. Test Specimens

6.1 General:

6.1.1 *Specimen Size*—Test specimens shall be either substantially full size or machined, as prescribed in the product specifications for the material being tested.

6.1.2 *Location*—Unless otherwise specified, the axis of the test specimen shall be located within the parent material as follows:

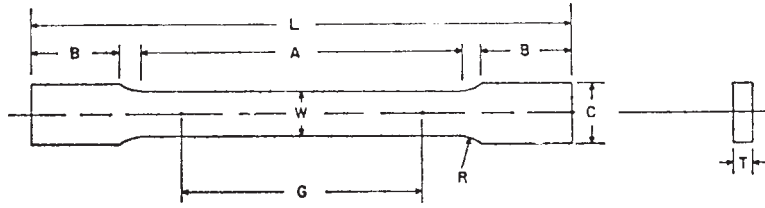

| | Dimensions | | |
|--|-------------------------|------------------------|------------------|
| | Standard Specimens | | Subsize Specimen |
| | Plate-Type, 1½-in. Wide | Sheet-Type, ½-in. Wide | ¼-in. Wide |
| | in. | in. | in. |
| G—Gage length (Note 1 and Note 2) | 8.00 ± 0.01 | 2.000 ± 0.005 | 1.000 ± 0.003 |
| W—Width (Note 3 and Note 4) | 1½ + ⅛, - ¼ | 0.500 ± 0.010 | 0.250 ± 0.005 |
| T—Thickness (Note 5) | | thickness of material | |
| R—Radius of fillet, min (Note 6) | 1 | ½ | ¼ |
| L—Over-all length, (Note 2, Note 7 and Note 8) | 18 | 8 | 4 |
| A—Length of reduced section, min | 9 | 2¼ | 1¼ |
| B—Length of grip section, (Note 8) | 3 | 2 | 1¼ |
| C—Width of grip section, approximate (Note 4 and Note 9) | 2 | ¾ | ¾ |

NOTE 1—For the 1½-in. wide specimen, punch marks for measuring elongation after fracture shall be made on the flat or on the edge of the specimen and within the reduced section. Either a set of nine or more punch marks 1 in. apart, or one or more pairs of punch marks 8 in. apart may be used.

NOTE 2—When elongation measurements of 1½-in. wide specimens are not required, a minimum length of reduced section (A) of 2¼ in. may be used with all other dimensions similar to those of the plate-type specimen.

NOTE 3—For the three sizes of specimens, the ends of the reduced section shall not differ in width by more than 0.004, 0.002 or 0.001 in., respectively. Also, there may be a gradual decrease in width from the ends to the center, but the width at each end shall not be more than 0.015, 0.005, or 0.003 in., respectively, larger than the width at the center.

NOTE 4—For each of the three sizes of specimens, narrower widths (W and C) may be used when necessary. In such cases the width of the reduced section should be as large as the width of the material being tested permits; however, unless stated specifically, the requirements for elongation in a product specification shall not apply when these narrower specimens are used.

NOTE 5—The dimension T is the thickness of the test specimen as provided for in the applicable material specifications. Minimum thickness of 1½-in. wide specimens shall be ⅜ in. Maximum thickness of ½-in. and ¼-in. wide specimens shall be ¾ in. and ¼ in., respectively.

NOTE 6—For the 1½-in. wide specimen, a ½-in. minimum radius at the ends of the reduced section is permitted for steel specimens under 100 000 psi in tensile strength when a profile cutter is used to machine the reduced section.

NOTE 7—The dimension shown is suggested as a minimum. In determining the minimum length, the grips must not extend in to the transition section between Dimensions A and B, see Note 9.

NOTE 8—To aid in obtaining axial force application during testing of ¼-in. wide specimens, the over-all length should be as large as the material will permit, up to 8.00 in.

NOTE 9—It is desirable, if possible, to make the length of the grip section large enough to allow the specimen to extend into the grips a distance equal to two thirds or more of the length of the grips. If the thickness of ½-in. wide specimens is over ¾ in., longer grips and correspondingly longer grip sections of the specimen may be necessary to prevent failure in the grip section.

NOTE 10—For the three sizes of specimens, the ends of the specimen shall be symmetrical in width with the center line of the reduced section within 0.10, 0.05 and 0.005 in., respectively. However, for referee testing and when required by product specifications, the ends of the ½-in. wide specimen shall be symmetrical within 0.01 in.

NOTE 11—For each specimen type, the radii of all fillets shall be equal to each other within a tolerance of 0.05 in., and the centers of curvature of the two fillets at a particular end shall be located across from each other (on a line perpendicular to the centerline) within a tolerance of 0.10 in.

NOTE 12—Specimens with sides parallel throughout their length are permitted, except for referee testing, provided: (a) the above tolerances are used; (b) an adequate number of marks are provided for determination of elongation; and (c) when yield strength is determined, a suitable extensometer is used. If the fracture occurs at a distance of less than 2W from the edge of the gripping device, the tensile properties determined may not be representative of the material. In acceptance testing, if the properties meet the minimum requirements specified, no further testing is required, but if they are less than the minimum requirements, discard the test and retest.

FIG. 1 Rectangular Tension Test Specimens

6.1.2.1 At the center for products 1½ in. or less in thickness, diameter, or distance between flats.

6.1.2.2 Midway from the center to the surface for products over 1½ in. in thickness, diameter, or distance between flats.

6.1.3 *Specimen Machining*—Improperly prepared test specimens often are the reason for unsatisfactory and incorrect test results. It is important, therefore, that care be exercised in the preparation of specimens, particularly in the machining, to maximize precision and minimize bias in test results.

6.1.3.1 The reduced sections of prepared specimens should be free of cold work, notches, chatter marks, grooves, gouges, burrs, rough surfaces or edges, overheating, or any other condition which can deleteriously affect the properties to be measured.

NOTE 7—Punching or blanking of the reduced section may produce significant cold work or shear burrs, or both, along the edges which should be removed by machining.

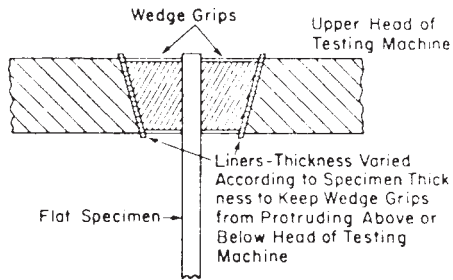

FIG. 2 Wedge Grips with Liners for Flat Specimens

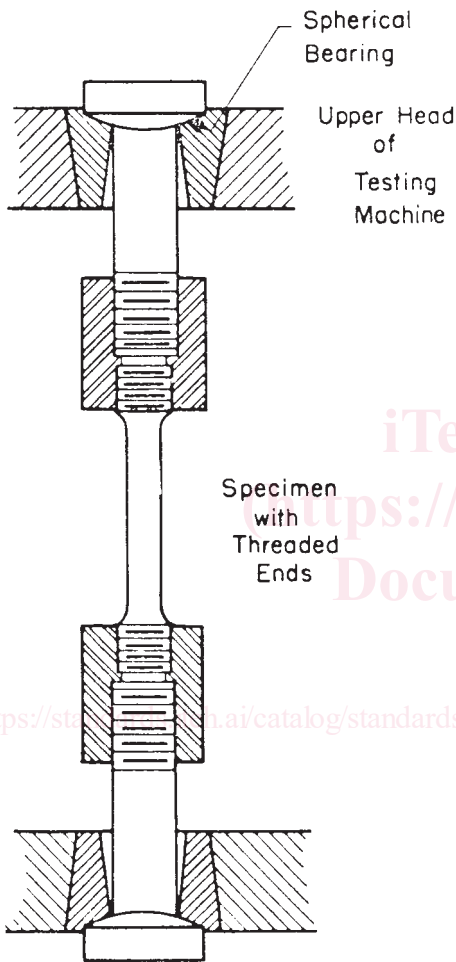

FIG. 3 Gripping Device for Threaded-End Specimens

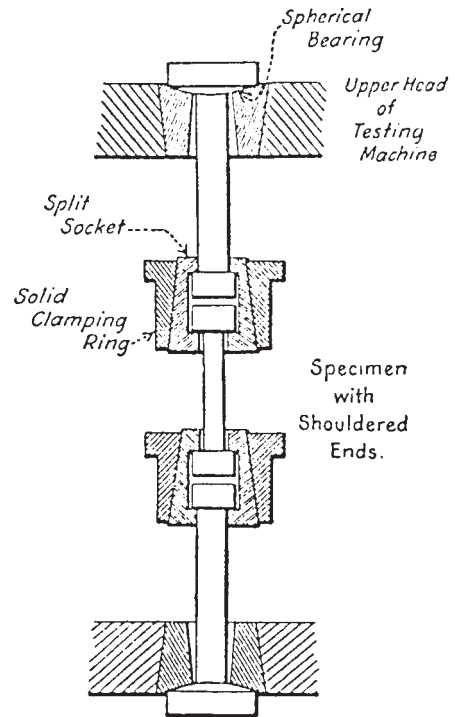

FIG. 4 Gripping Device for Shouldered-End Specimens

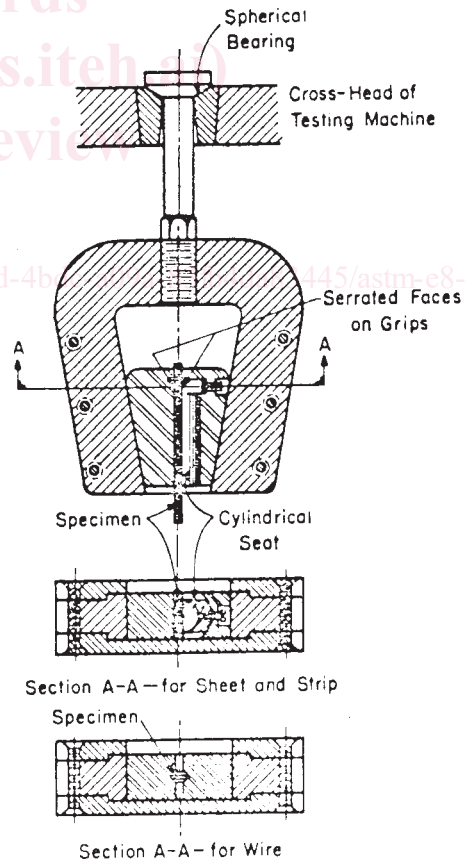

FIG. 5 Gripping Devices for Sheet and Wire Specimens

6.1.3.2 Within the reduced section of rectangular specimens, edges or corners should not be ground or abraded in a manner which could cause the actual cross-sectional area of the specimen to be significantly different from the calculated area.

6.1.3.3 For brittle materials, large radius fillets at the ends of the gage length should be used.

6.1.3.4 The cross-sectional area of the specimen should be smallest at the center of the reduced section to ensure fracture within the gage length. For this reason, a small taper is permitted in the reduced section of each of the specimens described in the following sections.

6.1.4 *Specimen Surface Finish*—When materials are tested with surface conditions other than as manufactured, the surface

finish of the test specimens should be as provided in the applicable product specifications.

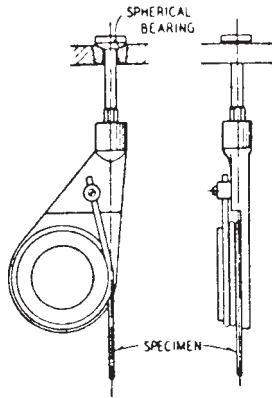

FIG. 6 Snubbing Device for Testing Wire

NOTE 8—Particular attention should be given to the uniformity and quality of surface finish of specimens for high strength and very low ductility materials since this has been shown to be a factor in the variability of test results.

6.2 *Plate-Type Specimens*—The standard plate-type test specimen is shown in Fig. 1. This specimen is used for testing metallic materials in the form of plate, shapes, and flat material having a nominal thickness of 3/16 in. or over. When product specifications so permit, other types of specimens may be used, as provided in 6.3, 6.4, and 6.5.

6.3 *Sheet-Type Specimens*:

6.3.1 The standard sheet-type test specimen is shown in Fig. 1. This specimen is used for testing metallic materials in the form of sheet, plate, flat wire, strip, band, hoop, rectangles, and shapes ranging in nominal thickness from 0.005 to 3/4 in. When

product specifications so permit, other types of specimens may be used, as provided in 6.2, 6.4, and 6.5.

NOTE 9—Test Methods E 345 may be used for tension testing of materials in thicknesses up to 0.0059 in.

6.3.2 Pin ends as shown in Fig. 7 may be used. In order to avoid buckling in tests of thin and high-strength materials, it may be necessary to use stiffening plates at the grip ends.

6.4 *Round Specimens*:

6.4.1 The standard 0.500-in. diameter round test specimen shown in Fig. 8 is used quite generally for testing metallic materials, both cast and wrought.

6.4.2 Fig. 8 also shows small-size specimens proportional to the standard specimen. These may be used when it is necessary to test material from which the standard specimen or specimens shown in Fig. 1 cannot be prepared. Other sizes of small round specimens may be used. In any such small-size specimen it is important that the gage length for measurement of elongation be four times the diameter of the specimen.

6.4.3 The shape of the ends of the specimen outside of the gage length shall be suitable to the material and of a shape to fit the holders or grips of the testing machine so that the forces may be applied axially. Fig. 9 shows specimens with various types of ends that have given satisfactory results.

6.5 *Specimens for Sheet, Strip, Flat Wire, and Plate*—In testing sheet, strip, flat wire, and plate, use a specimen type appropriate for the nominal thickness of the material, as described in the following:

6.5.1 For material with a nominal thickness of 0.0005-0.1875 in., use the sheet-type specimen described in 6.3.

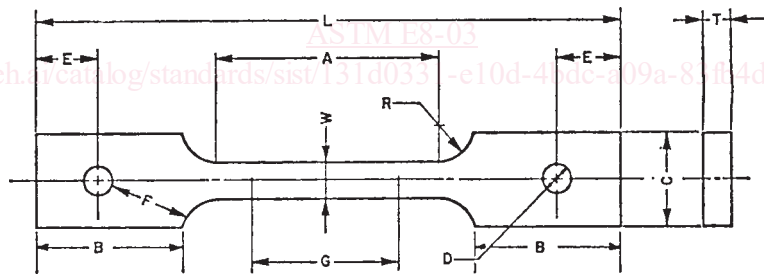

| Dimensions | in. |
|--|---------------|
| G—Gage length | 2.000 ± 0.005 |
| W—Width (Note 1) | 0.500 ± 0.010 |
| T—Thickness, max (Note 2) | 3/8 |
| R—Radius of fillet, min (Note 3) | 1/2 |
| L—Over-all length, min | 8 |
| A—Length of reduced section, min | 2 1/4 |
| B—Length of grip section, min | 2 |
| C—Width of grip section, approximate | 2 |
| D—Diameter of hole for pin, min (Note 4) | 1/2 |
| E—Edge distance from pin, approximate | 1 1/2 |
| F—Distance from hole to fillet, min | 1/2 |

NOTE 1—The ends of the reduced section shall differ in width by not more than 0.002 in. There may be a gradual taper in width from the ends to the center, but the width at each end shall be not more than 0.005 in. greater than the width at the center.

NOTE 2—The dimension T is the thickness of the test specimen as stated in the applicable product specifications.

NOTE 3—For some materials, a fillet radius R larger than 1/2 in. may be needed.

NOTE 4—Holes must be on center line of reduced section, within ±0.002 in.

NOTE 5—Variations of dimensions C, D, E, F, and L may be used that will permit failure within the gage length.

FIG. 7 Pin-Loaded Tension Test Specimen with 2-in. Gage Length

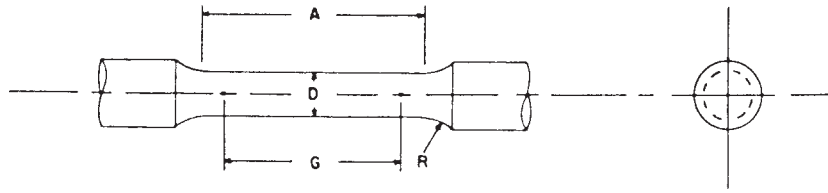

| | Dimensions | | | | |
|---|-------------------|---------------|---|---------------|---------------|
| | Standard Specimen | | Small-Size Specimens Proportional to Standard | | |
| | in. | in. | in. | in. | in. |
| Nominal Diameter | 0.500 | 0.350 | 0.250 | 0.160 | 0.113 |
| G—Gage length | 2.000 ± 0.005 | 1.400 ± 0.005 | 1.000 ± 0.005 | 0.640 ± 0.005 | 0.450 ± 0.005 |
| D—Diameter (Note 1) | 0.500 ± 0.010 | 0.350 ± 0.007 | 0.250 ± 0.005 | 0.160 ± 0.003 | 0.113 ± 0.002 |
| R—Radius of fillet, min | 3/8 | 1/4 | 3/16 | 5/32 | 3/32 |
| A—Length of reduced section, min (Note 2) | 2 1/4 | 1 3/4 | 1 1/4 | 3/4 | 5/8 |

NOTE 1—The reduced section may have a gradual taper from the ends toward the center, with the ends not more than 1 % larger in diameter than the center (controlling dimension).

NOTE 2—If desired, the length of the reduced section may be increased to accommodate an extensometer of any convenient gage length. Reference marks for the measurement of elongation should, nevertheless, be spaced at the indicated gage length.

NOTE 3—The gage length and fillets may be as shown, but the ends may be of any form to fit the holders of the testing machine in such a way that the load shall be axial (see Fig. 9). If the ends are to be held in wedge grips it is desirable, if possible, to make the length of the grip section great enough to allow the specimen to extend into the grips a distance equal to two thirds or more of the length of the grips.

NOTE 4—On the round specimens in Figs. 8 and 9, the gage lengths are equal to four times the nominal diameter. In some product specifications other specimens may be provided for, but unless the 4-to-1 ratio is maintained within dimensional tolerances, the elongation values may not be comparable with those obtained from the standard test specimen.

NOTE 5—The use of specimens smaller than 0.250-in. diameter shall be restricted to cases when the material to be tested is of insufficient size to obtain larger specimens or when all parties agree to their use for acceptance testing. Smaller specimens require suitable equipment and greater skill in both machining and testing.

NOTE 6—Five sizes of specimens often used have diameters of approximately 0.505, 0.357, 0.252, 0.160, and 0.113 in., the reason being to permit easy calculations of stress from loads, since the corresponding cross-sectional areas are equal or close to 0.200, 0.100, 0.0500, 0.0200, and 0.0100 in.², respectively. Thus, when the actual diameters agree with these values, the stresses (or strengths) may be computed using the simple multiplying factors 5, 10, 20, 50, and 100, respectively. (The metric equivalents of these five diameters do not result in correspondingly convenient cross-sectional areas and multiplying factors.)

FIG. 8 Standard 0.500-in. Round Tension Test Specimen with 2-in. Gage Length and Examples of Small-Size Specimens Proportional to the Standard Specimen

6.5.2 For material with a nominal thickness of 0.1875–0.500 in., use either the sheet-type specimen of 6.3 or the plate-type specimen of 6.2.

6.5.3 For material with a nominal thickness of 0.500–0.750 in., use either the sheet-type specimen of 6.3, the plate-type specimen of 6.2, or the largest practical size of round specimen described in 6.4.

6.5.4 For material with a nominal thickness of 0.750 in., or greater, use the plate-type specimen of paragraph 6.2 or the largest practical size of round specimen described in 6.4.

6.5.4.1 If the product specifications permit, material of a thickness of 0.750 in., or greater may be tested using a modified sheet-type specimen conforming to the configuration shown by Fig. 2. The thickness of this modified specimen must be machined to 0.400 ± 0.020 in., and must be uniform within 0.004 in. throughout the reduced section. In the event of disagreement, a round specimen shall be used as the referee specimen.

6.6 Specimens for Wire, Rod, and Bar:

6.6.1 For round wire, rod, and bar, test specimens having the full cross-sectional area of the wire, rod, or bar shall be used wherever practicable. The gage length for the measurement of elongation of wire less than 1/8 in. in diameter shall be as prescribed in product specifications. In testing wire, rod, or bar that has a 1/8-in. or larger diameter, unless otherwise specified,

a gage length equal to four times the diameter shall be used. The total length of the specimens shall be at least equal to the gage length plus the length of material required for the full use of the grips employed.

6.6.2 For wire of octagonal, hexagonal, or square cross section, for rod or bar of round cross section where the specimen required in 6.6.1 is not practicable, and for rod or bar of octagonal, hexagonal, or square cross section, one of the following types of specimens shall be used:

6.6.2.1 Full Cross Section (Note 10)—It is permissible to reduce the test section slightly with abrasive cloth or paper, or machine it sufficiently to ensure fracture within the gage marks. For material not exceeding 0.188 in. in diameter or distance between flats, the cross-sectional area may be reduced to not less than 90 % of the original area without changing the shape of the cross section. For material over 0.188 in. in diameter or distance between flats, the diameter or distance between flats may be reduced by not more than 0.010 in. without changing the shape of the cross section. Square, hexagonal, or octagonal wire or rod not exceeding 0.188 in. between flats may be turned to a round having a cross-sectional area not smaller than 90 % of the area of the maximum inscribed circle. Fillets, preferably with a radius of 3/8 in., but not less than 1/8 in., shall be used at the ends of the reduced sections. Square, hexagonal, or octagonal rod over 0.188 in.

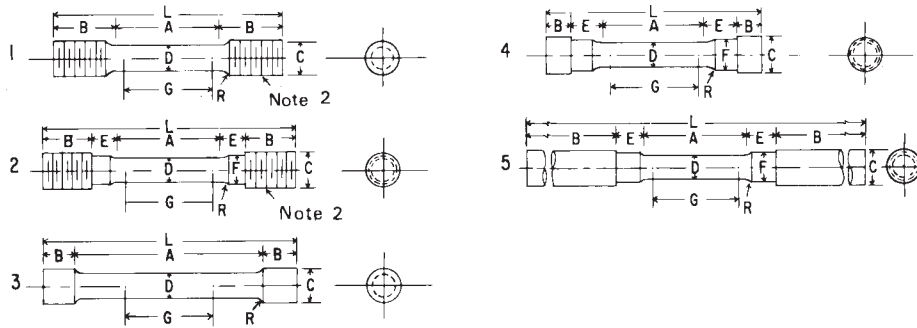

| | Dimensions | | | | |
|--|----------------------|------------------|--------------------|--------------------|---------------|
| | Specimen 1 | Specimen 2 | Specimen 3 | Specimen 4 | Specimen 5 |
| | in. | in. | in. | in. | in. |
| G—Gage length | 2.000 ± 0.005 | 2.000 ± 0.005 | 2.000 ± 0.005 | 2.000 ± 0.005 | 2.000 ± 0.005 |
| D—Diameter (Note 1) | 0.500 ± 0.010 | 0.500 ± 0.010 | 0.500 ± 0.010 | 0.500 ± 0.010 | 0.500 ± 0.010 |
| R—Radius of fillet, min | 3/8 | 3/8 | 1/16 | 3/8 | 3/8 |
| A—Length of reduced section | 2 1/4, min | 2 1/4, min | 4, approximately | 2 1/4, min | 2 1/4, min |
| L—Over-all length, approximate | 5 | 5 1/2 | 5 1/2 | 4 3/4 | 9 1/2 |
| B—Length of end section (Note 3) | 1 3/8, approximately | 1, approximately | 3/4, approximately | 1/2, approximately | 3, min |
| C—Diameter of end section | 3/4 | 3/4 | 23/32 | 7/8 | 3/4 |
| E—Length of shoulder and fillet section, approximate | ... | 5/8 | ... | 3/4 | 5/8 |
| F—Diameter of shoulder | ... | 5/8 | ... | 5/8 | 19/32 |

NOTE 1—The reduced section may have a gradual taper from the ends toward the center with the ends not more than 0.005 in. larger in diameter than the center.

NOTE 2—On Specimens 1 and 2, any standard thread is permissible that provides for proper alignment and aids in assuring that the specimen will break within the reduced section.

NOTE 3—On Specimen 5 it is desirable, if possible, to make the length of the grip section great enough to allow the specimen to extend into the grips a distance equal to two thirds or more of the length of the grips.

FIG. 9 Various Types of Ends for Standard Round Tension Test Specimens

between flats may be turned to a round having a diameter no smaller than 0.010 in. less than the original distance between flats.

NOTE 10—The ends of copper or copper alloy specimens may be flattened 10 to 50 % from the original dimension in a jig similar to that shown in Fig. 10, to facilitate fracture within the gage marks. In flattening the opposite ends of the test specimen, care shall be taken to ensure that the four flattened surfaces are parallel and that the two parallel surfaces on the same side of the axis of the test specimen lie in the same plane.

6.6.2.2 For rod and bar, the largest practical size of round specimen as described in 6.4 may be used in place of a test specimen of full cross section. Unless otherwise specified in

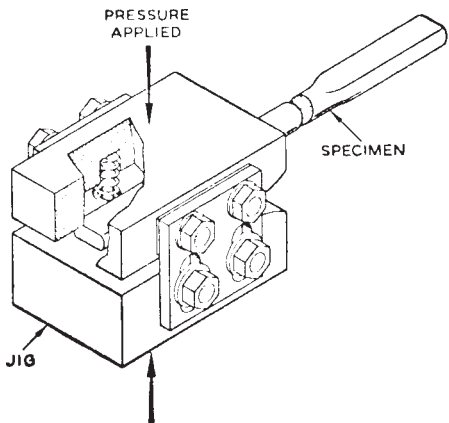

FIG. 10 Squeezing Jig for Flattening Ends of Full-Size Tension Test Specimens

the product specification, specimens shall be parallel to the direction of rolling or extrusion.

6.7 Specimens for Rectangular Bar— In testing rectangular bar one of the following types of specimens shall be used:

6.7.1 Full Cross Section—It is permissible to reduce the width of the specimen throughout the test section with abrasive cloth or paper, or by machining sufficiently to facilitate fracture within the gage marks, but in no case shall the reduced width be less than 90 % of the original. The edges of the midlength of the reduced section not less than 3/4 in. in length shall be parallel to each other and to the longitudinal axis of the specimen within 0.002 in. Fillets, preferably with a radius of 3/8 in. but not less than 1/8 in. shall be used at the ends of the reduced sections.

6.7.2 Rectangular bar of thickness small enough to fit the grips of the testing machine but of too great width may be reduced in width by cutting to fit the grips, after which the cut surfaces shall be machined or cut and smoothed to ensure failure within the desired section. The reduced width shall be not less than the original bar thickness. Also, one of the types of specimens described in 6.2, 6.3, and 6.4 may be used.

6.8 Shapes, Structural and Other—In testing shapes other than those covered by the preceding sections, one of the types of specimens described in 6.2, 6.3, and 6.4 shall be used.

6.9 Specimens for Pipe and Tube (Note 11):

6.9.1 For all small tube (Note 11), particularly sizes 1 in. and under in nominal outside diameter, and frequently for larger sizes, except as limited by the testing equipment, it is standard practice to use tension test specimens of full-size

tubular sections. Snug-fitting metal plugs shall be inserted far enough into the ends of such tubular specimens to permit the testing machine jaws to grip the specimens properly. The plugs shall not extend into that part of the specimen on which the elongation is measured. Elongation is measured over a length of $4D$ unless otherwise stated in the product specification. Fig. 11 shows a suitable form of plug, the location of the plugs in the specimen, and the location of the specimen in the grips of the testing machine.

NOTE 11—The term “tube” is used to indicate tubular products in general, and includes pipe, tube, and tubing.

6.9.2 For large-diameter tube that cannot be tested in full section, longitudinal tension test specimens shall be cut as indicated in Fig. 12. Specimens from welded tube shall be located approximately 90° from the weld. If the tube-wall thickness is under $\frac{3}{4}$ in., either a specimen of the form and dimensions shown in Fig. 13 or one of the small-size specimens proportional to the standard $\frac{1}{2}$ -in. specimen, as mentioned in 6.4.2 and shown in Fig. 8, shall be used. Specimens of the type shown in Fig. 13 may be tested with grips having a surface contour corresponding to the curvature of the tube. When grips with curved faces are not available, the ends of the specimens may be flattened without heating. If the tube-wall thickness is $\frac{3}{4}$ in. or over, the standard specimen shown in Fig. 8 shall be used.

NOTE 12—In clamping of specimens from pipe and tube (as may be done during machining) or in flattening specimen ends (for gripping), care must be taken so as not to subject the reduced section to any deformation or cold work, as this would alter the mechanical properties.

6.9.3 Transverse tension test specimens for tube may be taken from rings cut from the ends of the tube as shown in Fig. 14. Flattening of the specimen may be either after separating as in A, or before separating as in B. Transverse tension test specimens for large tube under $\frac{3}{4}$ in. in wall thickness shall be either of the small-size specimens shown in Fig. 8 or of the form and dimensions shown for Specimen 2 in Fig. 13. When using the latter specimen, either or both surfaces of the

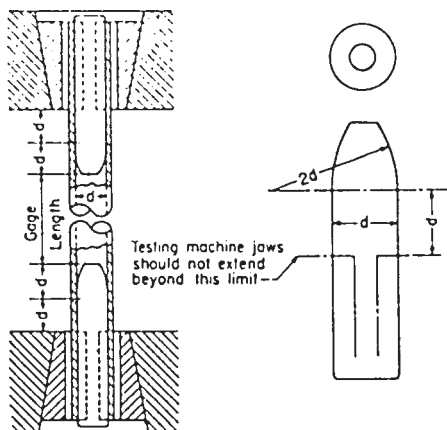

NOTE 1—The diameter of the plug shall have a slight taper from the line limiting the test machine jaws to the curved section.

FIG. 11 Metal Plugs for Testing Tubular Specimens, Proper Location of Plugs in Specimen and of Specimen in Heads of Testing Machine

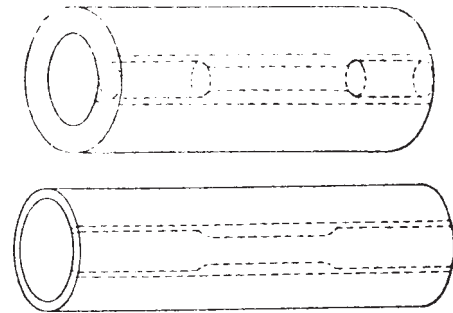

NOTE 1—The edges of the blank for the specimen shall be cut parallel to each other.

FIG. 12 Location from Which Longitudinal Tension Test Specimens Are to be Cut from Large-Diameter Tube

specimen may be machined to secure a uniform thickness, provided not more than 15 % of the normal wall thickness is removed from each surface. For large tube $\frac{3}{4}$ in. and over in wall thickness, the standard specimen shown in Fig. 8 shall be used for transverse tension tests. Specimens for transverse tension tests on large welded tube to determine the strength of welds shall be located perpendicular to the welded seams, with the welds at about the middle of their lengths.

6.10 *Specimens for Forgings*—For testing forgings, the largest round specimen described in 6.4 shall be used. If round specimens are not feasible, then the largest specimen described in 6.5 shall be used.

6.10.1 For forgings, specimens shall be taken as provided in the applicable product specifications, either from the predominant or thickest part of the forging from which a coupon can be obtained, or from a prolongation of the forging, or from separately forged coupons representative of the forging. When not otherwise specified, the axis of the specimen shall be parallel to the direction of grain flow.

6.11 *Specimens for Castings*—In testing castings either the standard specimen shown in Fig. 8 or the specimen shown in Fig. 15 shall be used unless otherwise provided in the product specifications.

6.11.1 Test coupons for castings shall be made as shown in Fig. 16 and Table 1.

6.12 *Specimen for Malleable Iron*—For testing malleable iron the test specimen shown in Fig. 17 shall be used, unless otherwise provided in the product specifications.

6.13 *Specimen for Die Castings*—For testing die castings the test specimen shown in Fig. 18 shall be used unless otherwise provided in the product specifications.

6.14 *Specimens for Powder Metallurgy (P/M) Materials*—For testing powder metallurgy (P/M) materials the test specimens shown in Fig. 19 and Fig. 20 shall be used, unless otherwise provided in the product specifications. When making test specimens in accordance with Fig. 19, shallow transverse grooves, or ridges, may be pressed in the ends to allow gripping by jaws machined to fit the grooves or ridges. Because of shape and other factors, the flat unmachined tensile test specimen (Fig. 19) in the heat treated condition will have an ultimate tensile strength of 50 % to 85 % of that determined in a machined round tensile test specimen (Fig. 20) of like composition and processing.

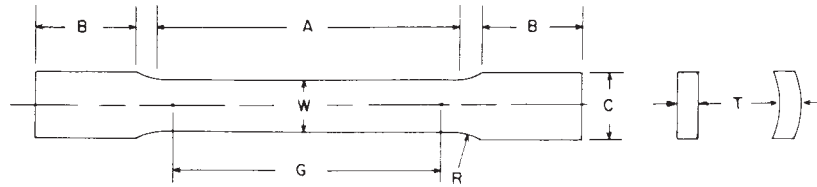

| | Dimensions | | | | | | |
|---|--------------------------------|---------------|-------------|---------------|---------------|---------------|---------------|
| | Specimen 1 | Specimen 2 | Specimen 3 | Specimen 4 | Specimen 5 | Specimen 6 | Specimen 7 |
| | in. | in. | in. | in. | in. | in. | in. |
| G—Gage length | 2.000 ± 0.005 | 2.000 ± 0.005 | 8.00 ± 0.01 | 2.000 ± 0.005 | 4.000 ± 0.005 | 2.000 ± 0.005 | 4.000 ± 0.005 |
| W—Width (Note 1) | 0.500 ± 0.010 | 1½ + ⅙ - ¼ | 1½ + ⅙ - ¼ | 0.750 ± 0.031 | 0.750 ± 0.031 | 1.000 ± 0.062 | 1.000 ± 0.062 |
| T—Thickness | measured thickness of specimen | | | | | | |
| R—Radius of fillet, min | ½ | 1 | 1 | 1 | 1 | 1 | 1 |
| A—Length of reduced section, min | 2¼ | 2¼ | 9 | 2¼ | 4½ | 2¼ | ½ |
| B—Length of grip section, min (Note 2) | 3 | 3 | 3 | 3 | 3 | 3 | 3 |
| C—Width of grip section, approximate (Note 3) | 1⅛ | 2 | 2 | 1 | 1 | 1½ | 1½ |

NOTE 1—The ends of the reduced section shall differ in width by not more than 0.002 in. for specimens 1 and 4, and not more than 0.005 in. for specimens 2, 3, 5, 6, and 7. There may be a gradual taper in width from the ends to the center, but the width at each end shall be not more than 0.005 in. greater than the width at the center for 2-in. gage length specimens, not more than 0.008 in. greater than the width at the center for 4-in. gage length specimens, and not more than 0.015 in. greater than the width at the center for 8-in. gage length specimens.

NOTE 2—It is desirable, if possible, to make the length of the grip section great enough to allow the specimen to extend into the grips a distance equal to two thirds or more of the length of the grips.

NOTE 3—The ends of the specimen shall be symmetrical with the center line of the reduced section within 0.05 in. for specimens 1, 4, and 5, and 0.10 in. for specimens 2, 3, 6, and 7.

NOTE 4—For each specimen type, the radii of all fillets shall be equal to each other within a tolerance of 0.05 in., and the centers of curvature of the two fillets at a particular end shall be located across from each other (on a line perpendicular to the centerline) within a tolerance of 0.10 in.

NOTE 5—For circular segments, the cross-sectional area may be calculated by multiplying *W* and *T*. If the ratio of the dimension *W* to the diameter of the tubular section is larger than about ⅙, the error in using this method to calculate the cross-sectional area may be appreciable. In this case, the exact equation (see section 7.2.3) must be used to determine the area.

NOTE 6—Specimens with *G/W* less than 4 should not be used for determination of elongation.

NOTE 7—Specimens with sides parallel throughout their length are permitted, except for referee testing, provided: (a) the above tolerances are used; (b) an adequate number of marks are provided for determination of elongation; and (c) when yield strength is determined, a suitable extensometer is used. If the fracture occurs at a distance of less than 2*W* from the edge of the gripping device, the tensile properties determined may not be representative of the material. If the properties meet the minimum requirements specified, no further testing is required, but if they are less than the minimum requirements, discard the test and retest.

FIG. 13 Tension Test Specimens for Large-Diameter Tubular Products

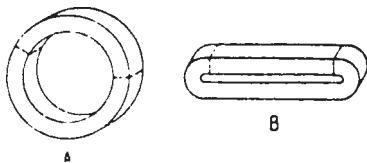

FIG. 14 Location of Transverse Tension Test Specimen in Ring Cut from Tubular Products

7. Procedures

7.1 Preparation of the Test Machine— Upon startup, or following a prolonged period of machine inactivity, the test machine should be exercised or warmed up to normal operating temperatures to minimize errors that may result from transient conditions.

7.2 Measurement of Dimensions of Test Specimens:

7.2.1 To determine the cross-sectional area of a test specimen, measure the dimensions of the cross section at the center of the reduced section. For referee testing of specimens under

3/16 in. in their least dimension, measure the dimensions where the least cross-sectional area is found. Measure and record the cross-sectional dimensions of tension test specimens 0.200 in. and over to the nearest 0.001 in.; the cross-sectional dimensions from 0.100 in. but less than 0.200 in., to the nearest 0.0005 in.; the cross-sectional dimensions from 0.020 in. but less than 0.100 in., to the nearest 0.0001 in.; and when practical, the cross-sectional dimensions less than 0.020 in., to at least the nearest 1 % but in all cases to at least the nearest 0.0001 in.

NOTE 13—Accurate and precise measurement of specimen dimensions can be one of the most critical aspects of tension testing, depending on specimen geometry. See Appendix X2 for additional information.

NOTE 14—Rough surfaces due to the manufacturing process such as hot rolling, metallic coating, etc., may lead to inaccuracy of the computed areas greater than the measured dimensions would indicate. Therefore, cross-sectional dimensions of test specimens with rough surfaces due to processing may be measured and recorded to the nearest 0.001 in.

NOTE 15—See X2.9 for cautionary information on measurements taken

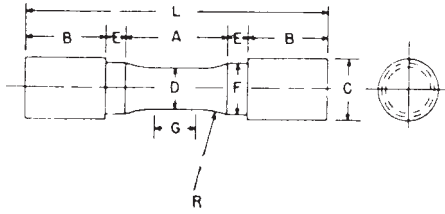

| | Dimensions | | |
|--|---|---------------|-------------|
| | Specimen 1 | Specimen 2 | Specimen 3 |
| | in. | in. | in. |
| G—Length of parallel section | Shall be equal to or greater than diameter <i>D</i> | | |
| <i>D</i> —Diameter | 0.500 ± 0.010 | 0.750 ± 0.015 | 1.25 ± 0.02 |
| <i>R</i> —Radius of fillet, min | 1 | 1 | 2 |
| <i>A</i> —Length of reduced section, min | 1¼ | 1½ | 2¼ |
| <i>L</i> —Over-all length, min | ¾ | 4 | 6¾ |
| <i>B</i> —Length of end section, approximate | 1 | 1 | 1¾ |
| <i>C</i> —Diameter of end section, approximate | ¾ | 1½ | 1⅞ |
| <i>E</i> —Length of shoulder, min | ¼ | ¼ | 5/16 |
| <i>F</i> —Diameter of shoulder | 5/8 ± 1/64 | 1¼ ± 1/64 | 1⅞ ± 1/64 |

NOTE 1—Note—The reduced section and shoulders (dimensions *A*, *D*, *E*, *F*, *G*, and *R*) shall be as shown, but the ends may be of any form to fit the holders of the testing machine in such a way that the force can be axial. Commonly the ends are threaded and have the dimensions *B* and *C* given above.

FIG. 15 Standard Tension Test Specimen for Cast Iron

from coated metal products.

7.2.2 Determine the cross-sectional area of a full-size test specimen of uniform but nonsymmetrical cross section by determining the mass of a length not less than 20 times longer than the largest cross-sectional dimension.

7.2.2.1 Determine the weight to the nearest 0.5 % or less.

7.2.2.2 The cross-sectional area is equal to the mass of the specimen divided by the length and divided by the density of the material.

7.2.3 When using specimens of the type shown in Fig. 13 taken from tubes, the cross-sectional area shall be determined as follows:

If $D/W \leq 6$:

$$A = [(W/4) \times (D^2 - W^2)^{1/2}] + [(D^2/4) \times \arcsin(W/D)] - [(W/4) \times ((D - 2T)^2 - W^2)^{1/2}] - [(D - 2T)/2)^2 \times \arcsin(W/(D - 2T))] \quad (1)$$

where:

- A* = exact cross-sectional area, in.²,
 - W* = width of the specimen in the reduced section, in.,
 - D* = measured outside diameter of the tube, in., and
 - T* = measured wall thickness of the specimen, in.
- arcsin values to be in radians

If $D/W > 6$, the exact equation or the following equation may be used:

$$A = W \times T \quad (2)$$

where:

- A* = approximate cross-sectional area, in.²,
- W* = width of the specimen in the reduced section, in., and
- T* = measured wall thickness of the specimen, in.

NOTE 16—See X2.8 for cautionary information on measurements and calculations for specimens taken from large-diameter tubing.

7.3 Gage Length Marking of Test Specimens:

7.3.1 The gage length for the determination of elongation shall be in accordance with the product specifications for the material being tested. Gage marks shall be stamped lightly with a punch, scribed lightly with dividers or drawn with ink as preferred. For material that is sensitive to the effect of slight notches and for small specimens, the use of layout ink will aid in locating the original gage marks after fracture.

7.3.2 For materials where the specified elongation is 3 % or less, measure the original gage length to the nearest 0.002 in. prior to testing.

7.4 Zeroing of the Testing Machine:

7.4.1 The testing machine shall be set up in such a manner that zero force indication signifies a state of zero force on the specimen. Any force (or preload) imparted by the gripping of the specimen (see Note 17) must be indicated by the force measuring system unless the preload is physically removed prior to testing. Artificial methods of removing the preload on the specimen, such as taring it out by a zero adjust pot or removing it mathematically by software, are prohibited because these would affect the accuracy of the test results.

NOTE 17—Preloads generated by gripping of specimens may be either tensile or compressive in nature and may be the result of such things as:

- grip design
- malfunction of gripping apparatus (sticking, binding, etc.)
- excessive gripping force
- sensitivity of the control loop

NOTE 18—It is the operator's responsibility to verify that an observed preload is acceptable and to ensure that grips operate in a smooth manner. Unless otherwise specified, it is recommended that momentary (dynamic) forces due to gripping not exceed 20 % of the material's nominal yield strength and that static preloads not exceed 10 % of the material's nominal yield strength.

7.5 Gripping of the Test Specimen:

7.5.1 For specimens with reduced sections, gripping of the specimen shall be restricted to the grip section, because gripping in the reduced section or in the fillet can significantly affect test results.

7.6 Speed of Testing:

7.6.1 Speed of testing may be defined in terms of (a) rate of straining of the specimen, (b) rate of stressing of the specimen, (c) rate of separation of the two heads of the testing machine during a test, (d) the elapsed time for completing part or all of the test, or (e) free-running crosshead speed (rate of movement of the crosshead of the testing machine when not under load).

7.6.2 Specifying suitable numerical limits for speed and selection of the method are the responsibilities of the product committees. Suitable limits for speed of testing should be specified for materials for which the differences resulting from the use of different speeds are of such magnitude that the test