



SLOVENSKI STANDARD SIST EN 1822-4:2010

01-januar-2010

BUXca Yý U
SIST EN 1822-4:2001

J]gc_c`i]b_cj]h`nfU b]`Z]`f]`fD5 ž<9D5]b`i @D5Ł!("XY.`8 c`c Ub^`dfYdi ý Ub`U
XYWj `g_cn]`Z]`fg_Y`Y`Ya Ybh`f`b YfcXU`g`g_Yb]fUb^`Ya Ł

High efficiency air filters (EPA, HEPA and ULPA) - Part 4: Determining leakage of filter elements (scan method)

Schwebstofffilter (EPA, HEPA und ULPA) -Teil 4: Leckprüfung des Filterelementes (Scan-Verfahren)

Filtres à air à haute efficacité (EPA, HEPA et ULPA) - Partie 4: Essais d'étanchéité de l'élément filtrant (méthode d'exploration)

ITIH STANDARD PREVIEW
(standards.iteh.ai)

Ta slovenski standard je istoveten z: EN 1822-4:2009

ICS:

23.120 Ventilators. Fans. Air-conditioners

SIST EN 1822-4:2010 en

iTeh STANDARD PREVIEW
(standards.iteh.ai)

SIST EN 1822-4:2010

<https://standards.iteh.ai/catalog/standards/sist/e58df86c-3f18-4d67-8268-dc719ab84c05/sist-en-1822-4-2010>

English Version

High efficiency air filters (EPA, HEPA and ULPA) - Part 4: Determining leakage of filter elements (scan method)

Filtres à air à haute efficacité (EPA, HEPA et ULPA) -
Partie 4: Essais d'étanchéité de l'élément filtrant (méthode
d'exploration)

Schwebstofffilter (EPA, HEPA und ULPA) - Teil 4:
Leckprüfung des Filterelementes (Scan-Verfahren)

This European Standard was approved by CEN on 17 October 2009.

CEN members are bound to comply with the CEN/CENELEC Internal Regulations which stipulate the conditions for giving this European Standard the status of a national standard without any alteration. Up-to-date lists and bibliographical references concerning such national standards may be obtained on application to the CEN Management Centre or to any CEN member.

This European Standard exists in three official versions (English, French, German). A version in any other language made by translation under the responsibility of a CEN member into its own language and notified to the CEN Management Centre has the same status as the official versions.

CEN members are the national standards bodies of Austria, Belgium, Bulgaria, Cyprus, Czech Republic, Denmark, Estonia, Finland, France, Germany, Greece, Hungary, Iceland, Ireland, Italy, Latvia, Lithuania, Luxembourg, Malta, Netherlands, Norway, Poland, Portugal, Romania, Slovakia, Slovenia, Spain, Sweden, Switzerland and United Kingdom.

[SIST EN 1822-4:2010](https://standards.iteh.ai/catalog/standards/sist/e58df86c-3f18-4d67-8268-dc719ab84c05/sist-en-1822-4-2010)

<https://standards.iteh.ai/catalog/standards/sist/e58df86c-3f18-4d67-8268-dc719ab84c05/sist-en-1822-4-2010>



EUROPEAN COMMITTEE FOR STANDARDIZATION
COMITÉ EUROPÉEN DE NORMALISATION
EUROPÄISCHES KOMITEE FÜR NORMUNG

Management Centre: Avenue Marnix 17, B-1000 Brussels

Contents	Page
Foreword	4
Introduction	5
1 Scope	6
2 Normative references	6
3 Terms and definitions	6
4 Description of the procedure	7
5 Test filter	8
6 Test apparatus	8
6.1 Set-up of the test apparatus	8
6.2 Test duct	11
6.2.1 Test air conditioning	11
6.2.2 Adjustment of the volume flow rate	11
6.2.3 Measurement of the volume flow rate	11
6.2.4 Aerosol mixing duct	11
6.2.5 Test filter mounting assembly	11
6.2.6 Measuring points for the pressure difference	11
6.2.7 Sampling, upstream	11
6.2.8 Screening	12
6.3 Scanning assembly	12
6.3.1 General	12
6.3.2 Sampling, downstream	12
6.3.3 Probe arm	13
6.3.4 Aerosol transport lines	13
6.3.5 Provisions to move the probe	13
6.4 Aerosol generation and measurement techniques	13
6.4.1 General	13
6.4.2 Set-up for testing with a monodisperse test aerosol	14
6.4.3 Set-up for testing with a polydisperse test aerosol	14
7 Test air	14
8 Test procedure	15
8.1 General	15
8.2 Preparatory checks	15
8.3 Starting up the aerosol generator	16
8.4 Preparing the test filter	16
8.4.1 Installing the test filter	16
8.4.2 Flushing the test filter	16
8.5 Testing	16
8.5.1 Measuring the pressure drop	16
8.5.2 Testing with monodisperse test aerosol	17
8.5.3 Testing with polydisperse test aerosol	17
8.5.4 Leak testing (local penetration)	17
8.5.5 Determining the mean efficiency of the filter element	17
9 Evaluation	18
9.1 Calculating the penetration and the efficiency	18
9.2 Local penetration	19
9.3 Mean efficiency	20

9.4	Classification	20
10	Test report.....	20
11	Maintenance and inspection of the test apparatus.....	21
Annex A	(normative) Oil Thread Leak Test	23
Annex B	(normative) Determining the test parameters	24
B.1	General	24
B.2	Boundary conditions.....	24
B.3	Test filter data	24
B.4	Data for the apparatus	25
B.4.1	Particle counters	25
B.4.2	Downstream sampling probes	25
B.4.3	Loss factor	26
B.5	Sequence of calculation steps.....	26
B.6	Checking the isokinetic sampling	27
B.7	Choosing the probe speed	28
B.8	Minimum aerosol concentration	29
B.9	Maximum aerosol concentration	30
B.10	Leak signal	31
B.10.1	Effective value	31
B.10.2	Signal difference.....	32
Annex C	(informative) Example of an application with evaluation	34
Annex D	(informative) Leak Test with solid PSL Aerosol	37
D.1	Background.....	37
D.2	General Remarks	37
D.3	Test Procedure	37
D.4	Test Protocol.....	39
Annex E	(informative) 0,3 µm – 0,5 µm Particle Efficiency Leak Test	40
Bibliography	42

[SIST EN 1822-4:2010](https://standards.iteh.ai/catalog/standards/sist/c58d186c-3118-4d67-8268-dc719ab84c05/sist-en-1822-4-2010)
<https://standards.iteh.ai/catalog/standards/sist/c58d186c-3118-4d67-8268-dc719ab84c05/sist-en-1822-4-2010>

Foreword

This document (EN 1822-4:2009) has been prepared by Technical Committee CEN/TC 195 “Air filters for general air cleaning”, the secretariat of which is held by UNI.

This European Standard shall be given the status of a national standard, either by publication of an identical text or by endorsement, at the latest by May 2010, and conflicting national standards shall be withdrawn at the latest by May 2010.

Attention is drawn to the possibility that some of the elements of this document may be the subject of patent rights. CEN [and/or CENELEC] shall not be held responsible for identifying any or all such patent rights.

This document supersedes EN 1822-4:2000.

It contains requirements, fundamental principles of testing and the marking for efficient particulate air filters (EPA), high efficiency particulate air filters (HEPA) and ultra low penetration air filters (ULPA).

The complete European Standard EN 1822, *High efficiency air filters (EPA, HEPA and ULPA)* will consist of the following parts:

- *Part 1: Classification, performance testing, marking*
- *Part 2: Aerosol production, measuring equipment, particle counting statistics*
- *Part 3: Testing flat sheet filter media*
- *Part 4: Determining leakage of filter elements (scan method)*
- *Part 5 : Determining the efficiency of filter elements*

According to the CEN/CENELEC Internal Regulations, the national standards organizations of the following countries are bound to implement this European Standard: Austria, Belgium, Bulgaria, Cyprus, Czech Republic, Denmark, Estonia, Finland, France, Germany, Greece, Hungary, Iceland, Ireland, Italy, Latvia, Lithuania, Luxembourg, Malta, Netherlands, Norway, Poland, Portugal, Romania, Slovakia, Slovenia, Spain, Sweden, Switzerland and the United Kingdom.

Introduction

As decided by CEN/TC 195, this European Standard is based on particle counting methods which actually cover most needs of different applications. The difference between this European Standard and previous national standards lies in the technique used for the determination of the integral efficiency. Instead of mass relationships, this technique is based on particle counting at the most penetrating particle size (MPPS), which is for micro-glass filter mediums usually in the range of 0,12 µm to 0,25 µm. This method also allows to test ultra low penetration air filters, which was not possible with the previous test methods because of their inadequate sensitivity.

For Membrane and synthetic filter media, separate rules apply; see Annexes A and B of EN 1822-5:2009.

iTeh STANDARD PREVIEW (standards.iteh.ai)

[SIST EN 1822-4:2010](https://standards.iteh.ai/catalog/standards/sist/e58df86c-3f18-4d67-8268-dc719ab84c05/sist-en-1822-4-2010)

<https://standards.iteh.ai/catalog/standards/sist/e58df86c-3f18-4d67-8268-dc719ab84c05/sist-en-1822-4-2010>

EN 1822-4:2009 (E)**1 Scope**

This European Standard applies to efficient air filters (EPA), high efficiency air filters (HEPA) and ultra low penetration air filters (ULPA-filters) used in the field of ventilation and air conditioning and for technical processes, e.g. for applications in clean room technology or pharmaceutical industry.

It establishes a procedure for the determination of the efficiency on the basis of a particle counting method using an artificial test aerosol, and allows a standardized classification of these filters in terms of their efficiency.

This part of EN 1822 applies to the leak testing of filter elements. The scan method which is described in detail regarding procedure, apparatus and test conditions in the body of this standard is valid for the complete range of group H and U filters and is considered to be the reference test method for leak determination. The "Oil Thread Leak Test" according to Annex A and the "0,3 µm - 0,5 µm Particle Efficiency Leak Test" according to Annex E may be used alternatively but for defined classes of group H filters only.

2 Normative references

The following referenced documents are indispensable for the application of this document. For dated references, only the edition cited applies. For undated references, the latest edition of the referenced document (including any amendments) applies.

EN 1822-1:2009, *High efficiency air filters (EPA, HEPA and ULPA) — Part 1: Classification, performance testing, marking*

EN 1822-2, *High efficiency air filters (EPA, HEPA and ULPA) — Part 2: Aerosol production, measuring equipment, particle counting statistics*

EN 1822-3, *High efficiency air filters (EPA, HEPA and ULPA) — Part 3: Testing flat sheet filter media*

EN 1822-5:2009, *High efficiency air filters (EPA, HEPA and ULPA) — Part 5: Determining the efficiency of filter elements*

EN 14799:2007, *Air filters for general air cleaning — Terminology*

3 Terms and definitions

For the purposes of this document, the terms and definitions given in EN 14799:2007 and the following apply.

3.1**total particle count method**

particle counting method in which the total number of particles in a certain sample volume is determined without classification according to size (e.g. by using a condensation nucleus counter)

3.2**particle counting and sizing method**

particle counting method which allows both the determination of the number of particles and also the classification of the particles according to size (e.g. by using an optical particle counter)

3.3**particle flow rate**

number of particles which are measured or which flow past a specified cross section in unit time

3.4

particle flow distribution

distribution of the particle flow over a plane at right angles to the direction of flow

4 Description of the procedure

The leakage test serves to test the filter element for local penetration values which exceed permissible levels (see EN 1822-1).

For leakage testing the test filter is installed in the mounting assembly and subjected to a test air flow corresponding to the nominal air flow rate. After measuring the pressure drop at the nominal volume flow rate, the filter is purged and the test aerosol produced by the aerosol generator is mixed with the prepared test air along a mixing duct so that it is spread homogeneously over the cross-section of the duct.

The particle flow rate on the downstream side of the test filter is smaller than the particle flow rate reaching the filter on the upstream side by the factor mean penetration.

The manufacturing irregularities of the filter material or leaks lead to a variation of the particle flow rate over the filter face area. In addition, leaks at the boundary areas and within the components of the test filter (sealant, filter frame, seal of the filter mounting assembly) can lead locally to an increase in the particle flow rate on the downstream side of the test filter.

For the leakage test, the particle flow distribution shall be determined on the downstream side of the filter in order to check where the limit values are exceeded. The coordinates of these positions shall be recorded.

The scanning tracks shall also cover the area of the filter frame, the corners, the sealant between filter frame and the gasket so that possible leaks in these areas can also be detected. It is advisable to scan filters for leaks with their original gasket mounted and in the same mounting position and air flow direction as they are installed on site.

In order to measure the downstream particle flow distribution, a probe with defined geometry shall be used on the downstream side to take a specified partial flow as sample. From this partial flow, a sample volume flow rate shall be led to a particle counter which counts the particles and displays the results as a function of time. During the testing, the probe moves at a defined speed in touching or overlapping tracks without gaps (see B.4.2 and B.4.3) close to the downstream side of the filter element. The measuring period for the downstream particle flow distribution can be shortened by using several measuring systems (partial flow extractors/particle counters) operating in parallel.

The measurement of the coordinates of the probe, a defined probe speed, and measurement of the particle flow rate at sufficiently short intervals allow the localisation of leaks. In a further test step, the local penetration shall be measured at this position using a stationary probe.

The leakage tests shall always be conducted using MPPS particles (see EN 1822-3), except for filters with Membrane medium as per Annex E of this standard. The size distribution of the aerosol particles can be checked using a particle size analysis system (for example a differential mobility particle sizer, DMPS).

The leakage testing can be carried out using either a monodisperse or polydisperse test aerosol. It shall be ensured that the median particle diameter corresponds to the MPPS particle diameter, at which the filter medium has its minimum efficiency.

When testing with a monodisperse aerosol, the total particle counting method can be used with a condensation nucleus counter (CNC) or an optical particle counter (OPC; e.g. a laser particle counter).

When using a polydisperse aerosol, an optical particle counter shall be used which counts the particles and measures their size distribution.

EN 1822-4:2009 (E)

If scan testing is carried out as an automatic procedure it also allows determination of the mean efficiency of the test filter from the measurement of the particle concentration. The mean particle concentration on the downstream side is calculated from the total particle number counted while the probe traverses the passage area. The reference volume is the volume of air analyzed by the particle counter over this period of time. The particle concentration on the upstream side of the test filter shall be measured at a representative position on the duct cross-section. This method for determining the integral efficiency is equivalent to the method with fixed probes specified in EN 1822-5.

5 Test filter

A test filter shall be used for the leak testing which does not show any visible signs of damage or other irregularities, and which can be sealed in position and subjected to flow in accordance with requirements. The temperature of the test filter during the tests shall correspond to the temperature of the test air. The filter element shall be handled with care, and shall be clearly and permanently marked with the following details:

- a) Designation of the filter element;
- b) The upstream side of the filter element.

6 Test apparatus**6.1 Set-up of the test apparatus**

Figure 1 shows the set-up of the test apparatus. This layout is valid for tests with a monodisperse or with a polydisperse aerosol. The only differences between these lie in the technique used to measure the particles and the way the aerosol is generated.

iTeH STANDARD PREVIEW
(standards.iteh.ai)
SIST EN 1822-4:2010
<https://standards.iteh.ai/catalog/standards/sist/e58df86c-3f18-4d67-8268-dc719ab84c05/sist-en-1822-4-2010>

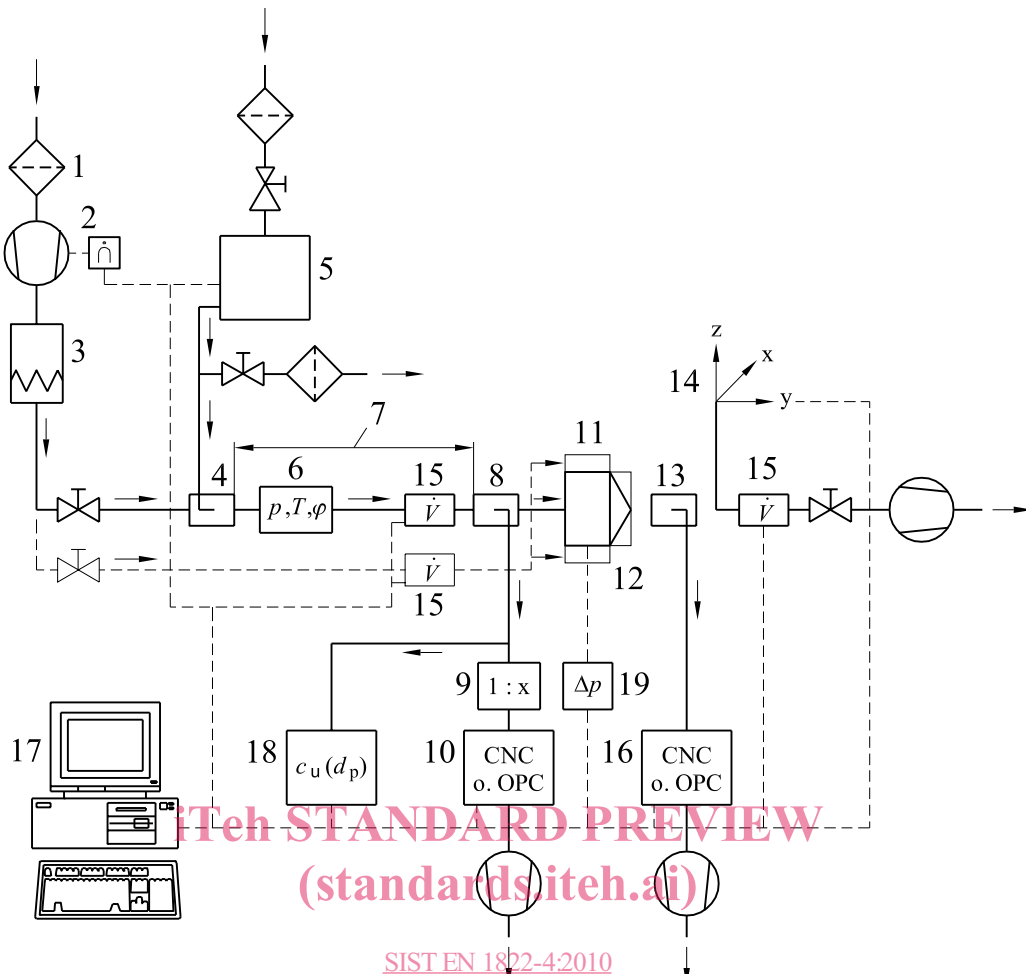

SIST EN 1822-4:2010
<https://standards.iteh.ai/catalog/standards/sist/e58df86c-3f18-4d67-8268-dc719ab84c05/sist-en-1822-4-2010>

Key

- | | | | |
|---|--|----|--|
| 1 | Pre-filter for the test air | 10 | Particle counter, upstream |
| 2 | Fan with speed regulator | 11 | Sheath flow (optional) |
| 3 | Air heater | 12 | Test filter |
| 4 | Aerosol inlet in the duct | 13 | Sampling point and partial flow extraction, downstream |
| 5 | Aerosol generator with conditioning of supply air and aerosol flow regulator | 14 | Traversing system for probe |
| 6 | Measurement of atmospheric pressure, temperature and relative humidity | 15 | Volume flow rate measurement |
| 7 | Upstream side mixing section | 16 | Particle counter, downstream |
| 8 | Sampling point for upstream particle counting | 17 | Computer for control and data storage |
| 9 | Dilution system (optional) | 18 | Measuring system to check the test aerosol |
| | | 19 | Measurement of differential pressure |

Figure 1 — Diagram of test apparatus

An example of a test rig is shown in Figure 2 (without particle measuring equipment).

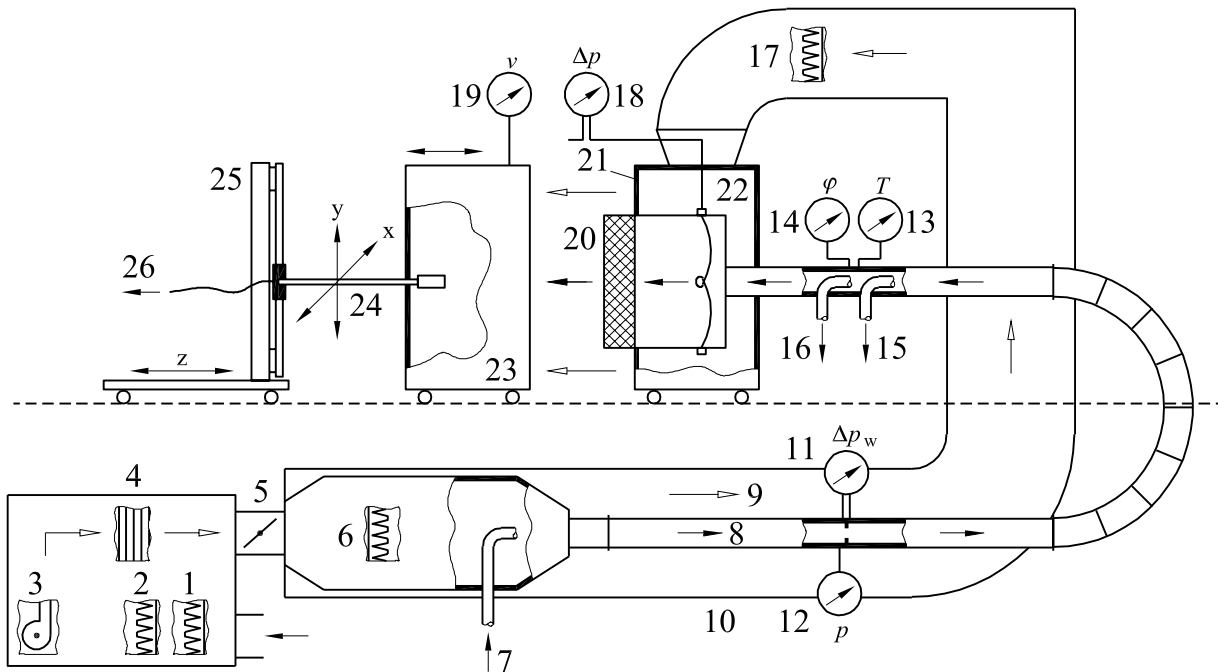

Key

- | | |
|---|--|
| 1 Coarse dust filter | 15 Sampling point for particle size analysis |
| 2 Fine dust filter | 16 Sampling point, upstream |
| 3 Fan | 17 High efficiency air filter for the sheath air |
| 4 Air heater | 18 Measurement of pressure drop |
| 5 Dampers to adjust test and sheath air | 19 Measurement of sheath air speed |
| 6 High efficiency air filter for the test air | 20 Test filter |
| 7 Aerosol inlet in the duct | 21 Flow equalizer for the sheath air flow |
| 8 Test air flow | 22 Filter mounting assembly |
| 9 Sheath air flow | 23 Screening (linked to the filter mounting assembly during the testing) |
| 10 Effective pressure measuring device | 24 Traversing probe arm with downstream sampling probe |
| 11 Differential pressure | 25 Probe traversing system |
| 12 Atmospheric pressure | 26 Downstream sampling point |
| 13 Temperature measurement | |
| 14 Hygrometer | |

Figure 2 — Test duct for scan testing

The basic details for the generation and neutralization of the aerosol, together with the details of suitable types of equipment and detailed descriptions of measuring instruments needed for the testing, are contained in EN 1822-2.

6.2 Test duct

6.2.1 Test air conditioning

The test air conditioning unit contains the equipment needed to condition the test air flow (see Clause 7).

The test air flow shall be so prepared that it complies with the specifications in Clause 7 and does not exceed the limit values specified there during the course of the efficiency testing.

6.2.2 Adjustment of the volume flow rate

It shall be possible by means of a suitable provision (e.g. changes to the speed of the fan, or by dampers) to produce the volume flow rate with a reproducibility of $\pm 3\%$. The nominal volume flow rate shall then remain in this range throughout the testing.

6.2.3 Measurement of the volume flow rate

The volume flow rate shall be measured using a standardized or calibrated method (e.g. measurement of the pressure drop using standardized damper equipment such as orifice plates, nozzles, Venturi tubes in accordance with EN ISO 5167-1).

The limit error of measurement shall not exceed 5 % (of the measured value).

6.2.4 Aerosol mixing duct

The aerosol input and the mixing duct (see example in Figure 1) shall be so constructed that the aerosol concentration measured at individual points of the duct cross section directly in front of the test filter shall not deviate by more than 10 % from the mean value obtained from at least nine measuring points spread evenly over the duct cross section.

SIST EN 1822-4:2010

6.2.5 Test filter mounting assembly

<http://standards.iteh.ai/catalog/standards/sist/e58df86c-3f18-4d67-8268-dc719ab84c05/sist-en-1822-4-2010>

The test filter mounting assembly shall ensure that the test filter can be sealed and subjected to flow in accordance with requirements. It shall not obstruct any part of the passage area of the filter.

It is advisable to scan filters for leaks in the same mounting position and air flow direction as they are installed on site.

6.2.6 Measuring points for the pressure difference

The measuring points for pressure shall be so arranged that the mean value of the difference between static pressure in the upstream flow and the pressure of the surrounding air can be measured. The plane of the pressure measurements shall be positioned in a region of uniform flow.

In rectangular or square test ducts, smooth holes with a diameter of 1 mm to 2 mm for the pressure measurements shall be bored in the middle of the duct walls, normal to the direction of flow. The four measurement holes shall be interconnected with a circular pipe.

6.2.7 Sampling, upstream

Samples are taken upstream by means of one or more sampling probes in front of the test filter. The probe diameter shall be chosen so that, at an average flow velocity, isokinetic conditions pertain at the given volume flow rate for the sample. Sampling errors which arise due to other flow velocities in the duct can be neglected due to the small size of the particles in the test aerosol. The connections to the particle counter shall be as short as possible.