**Adhesives — Determination of shear
behaviour of structural adhesives —**

**Part 2:
Tensile test method using thick adherends**

*Adhésifs — Détermination du comportement en cisaillement d'adhésifs
structuraux —*
Partie 2: Méthode d'essai en traction sur éprouvette épaisse

[ISO 11003-2:2001](https://standards.iteh.ai/catalog/standards/sist/b884e0bd-26bd-44ab-9a9a-4f39fa0e4000/iso-11003-2-2001)

<https://standards.iteh.ai/catalog/standards/sist/b884e0bd-26bd-44ab-9a9a-4f39fa0e4000/iso-11003-2-2001>



PDF disclaimer

This PDF file may contain embedded typefaces. In accordance with Adobe's licensing policy, this file may be printed or viewed but shall not be edited unless the typefaces which are embedded are licensed to and installed on the computer performing the editing. In downloading this file, parties accept therein the responsibility of not infringing Adobe's licensing policy. The ISO Central Secretariat accepts no liability in this area.

Adobe is a trademark of Adobe Systems Incorporated.

Details of the software products used to create this PDF file can be found in the General Info relative to the file; the PDF-creation parameters were optimized for printing. Every care has been taken to ensure that the file is suitable for use by ISO member bodies. In the unlikely event that a problem relating to it is found, please inform the Central Secretariat at the address given below.

iTeh STANDARD PREVIEW
(standards.iteh.ai)

[ISO 11003-2:2001](https://standards.iteh.ai/catalog/standards/sist/b884e0bd-26bd-44ab-9a9a-4f39fa0e4000/iso-11003-2-2001)

<https://standards.iteh.ai/catalog/standards/sist/b884e0bd-26bd-44ab-9a9a-4f39fa0e4000/iso-11003-2-2001>

© ISO 2001

All rights reserved. Unless otherwise specified, no part of this publication may be reproduced or utilized in any form or by any means, electronic or mechanical, including photocopying and microfilm, without permission in writing from either ISO at the address below or ISO's member body in the country of the requester.

ISO copyright office
Case postale 56 • CH-1211 Geneva 20
Tel. + 41 22 749 01 11
Fax + 41 22 749 09 47
E-mail copyright@iso.ch
Web www.iso.ch

Printed in Switzerland

Contents

	Page
1 Scope	1
2 Normative references	1
3 Principle	2
4 Apparatus	3
5 Specimen	3
6 Test specimen	5
7 Procedure	8
8 Calculations	10
9 Precision	12
10 Test report	12
Annex	
A Suitable extensometer design.....	14

iTeh STANDARD PREVIEW
(standards.iteh.ai)

[ISO 11003-2:2001](https://standards.iteh.ai/catalog/standards/sist/b884e0bd-26bd-44ab-9a9a-4f39fa0e4000/iso-11003-2-2001)

<https://standards.iteh.ai/catalog/standards/sist/b884e0bd-26bd-44ab-9a9a-4f39fa0e4000/iso-11003-2-2001>

Foreword

ISO (the International Organization for Standardization) is a worldwide federation of national standards bodies (ISO member bodies). The work of preparing International Standards is normally carried out through ISO technical committees. Each member body interested in a subject for which a technical committee has been established has the right to be represented on that committee. International organizations, governmental and non-governmental, in liaison with ISO, also take part in the work. ISO collaborates closely with the International Electrotechnical Commission (IEC) on all matters of electrotechnical standardization.

International Standards are drafted in accordance with the rules given in the ISO/IEC Directives, Part 3.

Draft International Standards adopted by the technical committees are circulated to the member bodies for voting. Publication as an International Standard requires approval by at least 75 % of the member bodies casting a vote.

Attention is drawn to the possibility that some of the elements of this part of ISO 11003 may be the subject of patent rights. ISO shall not be held responsible for identifying any or all such patent rights.

International Standard ISO 11003-2 was prepared by Technical Committee ISO/TC 61, *Plastics*, Subcommittee SC 11, *Products*.

This second edition cancels and replaces the first edition (ISO 11003-2:1993), which has been technically revised.

ISO 11003 consists of the following parts, under the general title *Adhesives — Determination of shear behaviour of structural adhesives*:

- *Part 1: Torsion test method using butt-bonded hollow cylinders*
- *Part 2: Tensile test method using thick adherends*

Annex A of this part of ISO 11003 is for information only.

Adhesives — Determination of shear behaviour of structural adhesives —

Part 2:

Tensile test method using thick adherends

1 Scope

This part of ISO 11003 specifies a test method for determining the shear behaviour of an adhesive in a single lap joint bonded assembly when subjected to a tensile force.

The test is performed on specimens consisting of thick, rigid adherends, with a short length of overlap, in order to obtain the most uniform distribution of shear stresses possible and to minimize other stress states which initiate failure.

This test method may be used to determine:

- the shear-stress against shear-strain curve to failure of the adhesive;
- the shear modulus of the adhesive;
- other adhesive properties that can be derived from the stress/strain curve such as secant shear modulus and maximum shear stress;
- the effect of temperature, environment, test speed, etc., on these properties.

2 Normative references

The following normative documents contain provisions which, through reference in this text, constitute provisions of this part of ISO 11003. For dated references, subsequent amendments to, or revisions of, any of these publications do not apply. However, parties to agreements based on this part of ISO 11003 are encouraged to investigate the possibility of applying the most recent editions of the normative documents indicated below. For undated references, the latest edition of the normative document referred to applies. Members of ISO and IEC maintain registers of currently valid International Standards.

ISO 291:1997, *Plastics — Standard atmospheres for conditioning and testing*

ISO 683-11:1987, *Heat-treatable steels, alloy steels and free-cutting steels — Part 11: Wrought case-hardening steels*

ISO 1052:1982, *Steels for general engineering purposes*

ISO 4588:1995, *Adhesives — Guidelines for the surface preparation of metals*

ISO 4995:2001, *Hot-rolled steel sheet of structural quality*

ISO 10365:1992, *Adhesives — Designation of main failure patterns*

3 Principle

An adhesively bonded test specimen (see Figure 1) is subjected to a tensile force so that the adhesive is stressed in shear.

The relative displacement of the adherends is measured using a purpose-built transducer located in the central region of the specimen. Force and displacement are measured from the start of application of the load until fracture of the specimen. The shear stresses and strains are then calculated from the bond dimensions.

Dimensions in millimetres

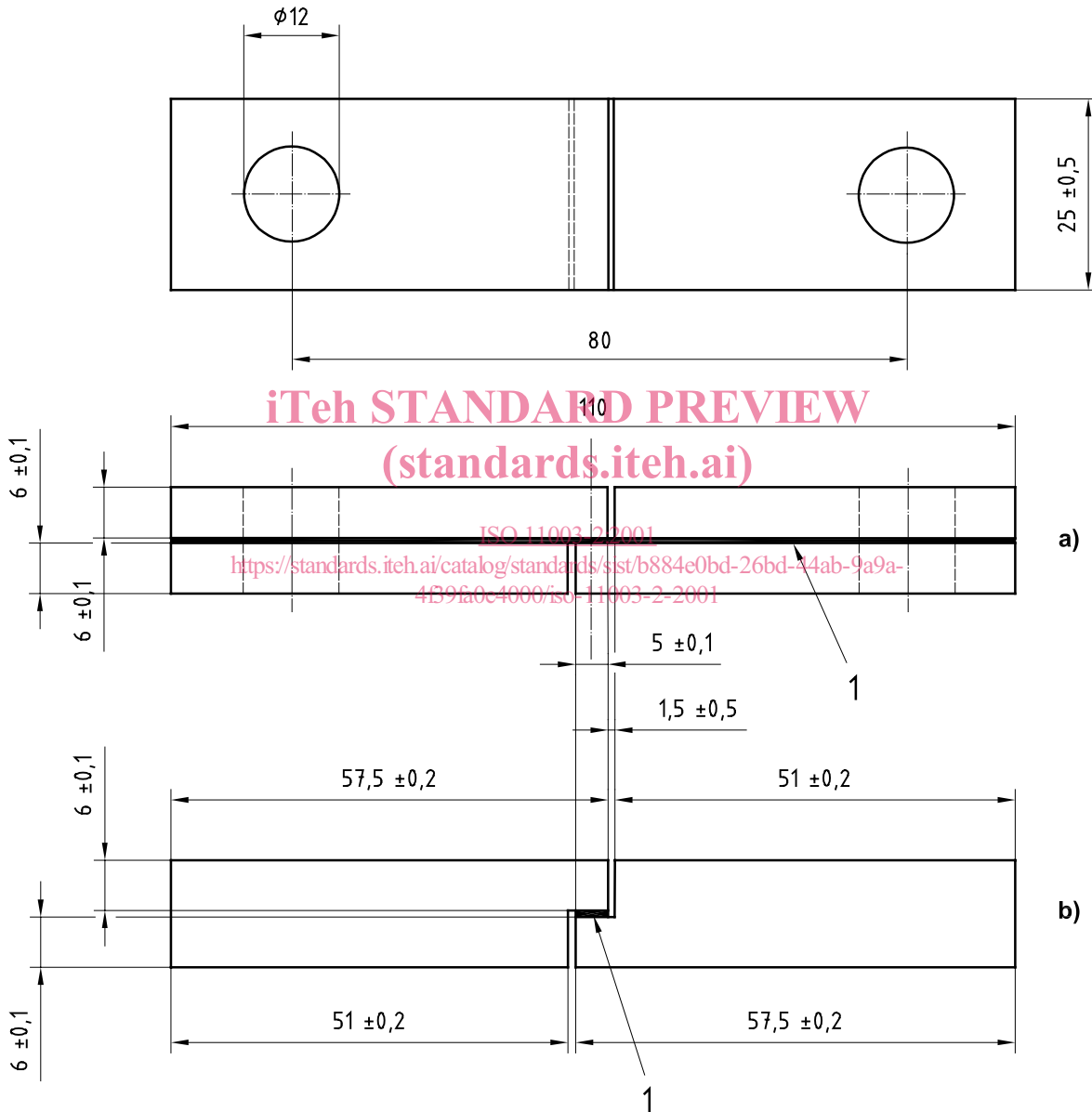

Key

1 Adhesive bond

Figure 1 — Specimen dimensions and configuration: a) Bonded adherends; b) Machined adherends

4 Apparatus

4.1 Tensile-testing machine, capable of producing fracture in the specimen at a tensile force between 10 % and 80 % of the full-scale range of the force transducer.

4.2 Device for introducing a force into the specimen, so that negligible torque develops when force is applied to the specimen. For this purpose, the simple universal-joint design shown in Figure 2 is satisfactory.

4.3 Force transducer, capable of measuring the force in the specimen with an accuracy of 1 % of the force at a shear strain of 0,01.

4.4 One or two extensometers (see note 2), for measuring the shear displacement between points of known separation on each adherend in the central region of the bond (see Figure 3 and annex A). The points of contact with the adherends shall be within a distance of 2 mm from the bonded faces. The device(s) shall be capable of measuring the shear displacement to an accuracy of 1 μm .

NOTE 1 During loading, each adherend will bend slightly, leading to a small rotation of the central (bonded) region of the test specimen. In order to achieve high accuracy in displacement measurements, it is necessary for the extensometer(s) to rotate with the specimen. This has been achieved in the design shown in Figure 3 by double-pin contact with one of the adherends.

NOTE 2 The use of two extensometers on opposing faces of the specimen is recommended to minimize, by averaging the extensometer readings, any contribution to measurements from a twisting moment applied to the specimen. The use of two extensometers will also serve to indicate any malfunctioning of one of the extensometers as revealed by significantly different readings from the two devices.

4.5 Data-logging equipment, to continuously record the relative displacement of the adherends and the applied load, from the start of application of the load until the specimen breaks.

4.6 Micrometer, having an accuracy of better than 0,002 mm, to measure the dimensions of the adherends.

4.7 Optical microscope, having an accuracy of better than 0,002 mm, to measure the thickness of the adhesive bond when the specimen configuration shown in Figure 1 a) is used.

5 Specimen

5.1 Specimen dimensions and configuration

Specimens shall be prepared either by bonding metal plates or strips together to produce the configuration shown in Figure 1 a) or by bonding adherends that have been machined to the shape shown in Figure 1 b). The dimensions of the specimen are given in Figure 1 and are the same, within variations in the bond thickness, for both preparation methods.

The bond thickness shall lie in the range 0,2 mm to 0,8 mm.

NOTE 1 The preferred bond thickness is 0,5 mm.

NOTE 2 The adherends shown in Figure 1 a) have a lower bending stiffness than the continuous geometry shown in Figure 1 b). Consequently, the peel stresses at the ends of the adhesive in the specimen in Figure 1 a) will be higher than those in the specimen in Figure 1 b). This should have only a small influence on stress and strain measurement but, since failure is generally initiated by these peel stresses, the specimen design shown in Figure 1 a) is likely to fail earlier (at lower stress and strain) than the design shown in Figure 1 b).

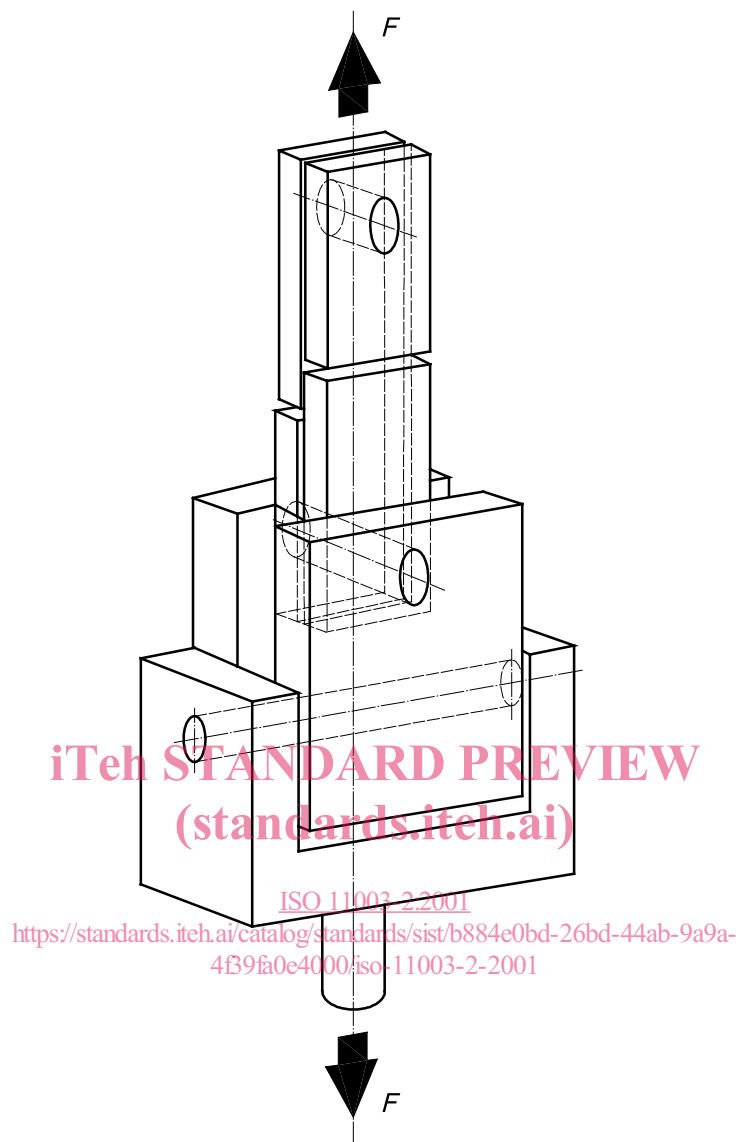

Figure 2 — Example of device for loading the specimen in a tensile-testing machine

5.2 Adherends

For the purpose of the measurement of the properties of the adhesive, steel adherends are recommended because of their high modulus.

NOTE A suitable steel is XC18 or E24, Grade 1 or 2.

Machine the panels or bars to be used for the adherends in accordance with ISO 683-11, ISO 1052 and ISO 4995 to the dimensions given in Figures 1 a) or 1 b) depending on which specimen configuration is chosen.

5.3 Preparation of surfaces before bonding

The surfaces to be bonded shall be prepared in accordance with ISO 4588 or by any other method leading to cohesive failure within the adhesive layer.

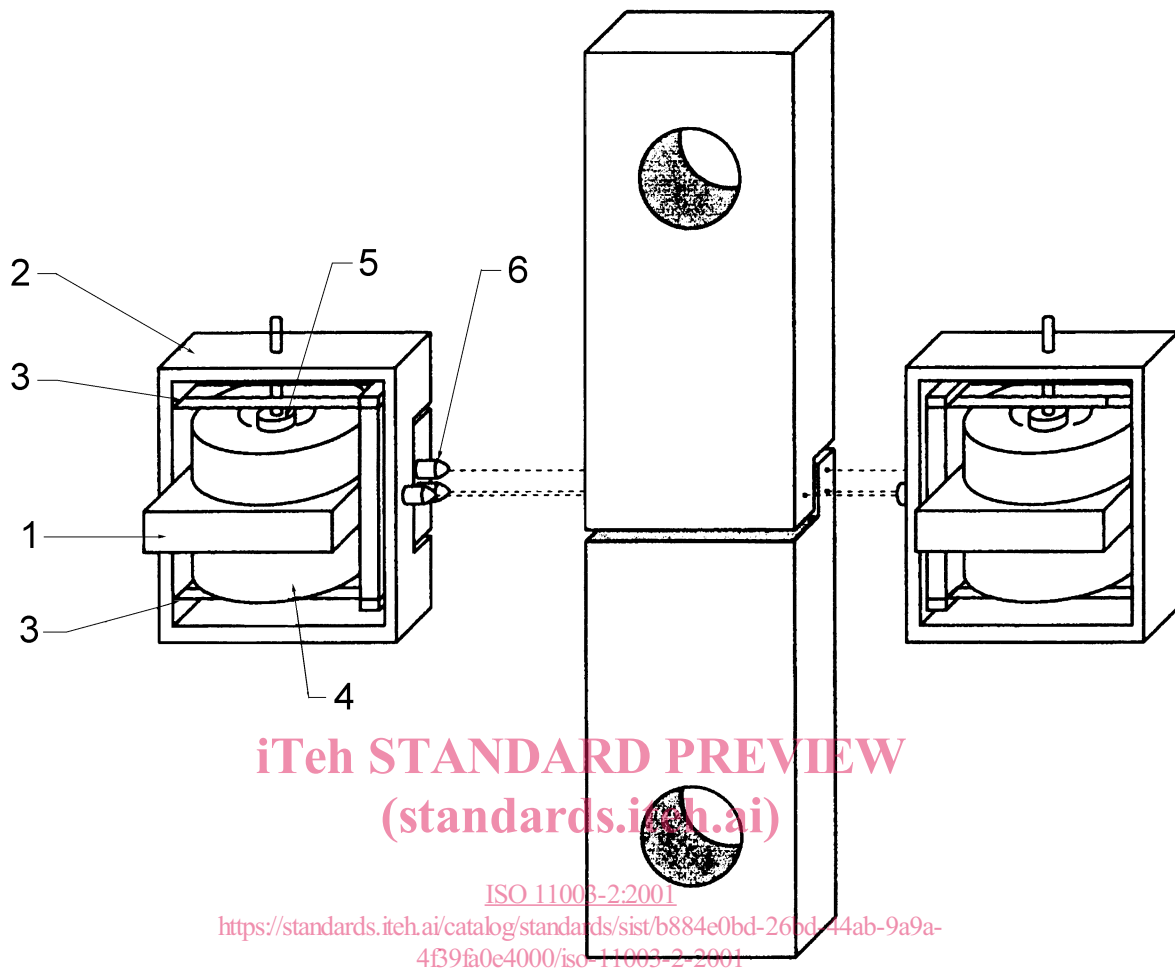
**Key**

- 1 Mobile inner part
- 2 Rigid outer frame
- 3 Steel leaf spring
- 4 Transducer coil
- 5 Transducer core
- 6 Tungsten pins

Figure 3 — Example of extensometer positioning

6 Test specimen

6.1 Preparation

6.1.1 Specimens with flat-ended adherends

6.1.1.1 General

Specimens with flat-ended adherends shall have the configuration shown in Figure 1 a) and may be prepared from uncut panels, from pre-cut panels or as individual specimens from machined plates.

6.1.1.2 Uncut panels

The panels from which the specimens are cut shall consist of two sheets with dimensions in accordance with Figure 4, bonded together in accordance with the adhesive manufacturer's instructions.

In order to define the thickness of the adhesive, shims or spacers (metal foil) or calibrated metal wires may be incorporated outside the area which will become the overlap zone.

Cut the bonded panels into specimens using a suitable tool such as a band saw. Then subject the specimens to the required machining. Perform the last pass on the edge of the specimen parallel to the longitudinal direction of the specimen so as to avoid any metal burrs along the bonded joint.

Drill holes at the ends of each specimen for pins to hold the specimen to the tensile-testing machine.

Delineate the overlap zone by milling two grooves as shown in Figure 5.

When the specimens are machined, care shall be taken to ensure that the assembly is not heated above 50 °C. No liquid shall be used for cooling.

6.1.1.3 Pre-cut panels

Proceed as in 6.1.1.2, using two pre-cut sheets so as to obtain a panel in accordance with Figure 6.

Two holes shall be provided in each sheet so that the two sheets can be superposed correctly using an assembly with two centering lugs.

Cut out and machine specimens as explained in 6.1.1.2.

iTeh STANDARD PREVIEW
(standards.iteh.ai)

6.1.1.4 Individual specimens

ISO 11003-2:2001

Bond two plates of dimensions 110 mm × 25 mm × 6 mm in accordance with the adhesive manufacturer's instructions, defining the thickness of the adhesive joint as indicated in 6.1.1.2. Ensure that the sides of the adherends are parallel to the nearest 0,1 mm.

Machine each specimen to the required size.

Drill holes for applying the load.

Make two grooves by milling to delineate the overlap.

Take the same precautions as in 6.1.1.2.

6.1.2 Specimens with stepped adherends

The adherends for this specimen type shall be machined to the dimensions given in Figure 1 b) prior to bonding. The adherends shall be bonded whilst held securely in a frame that ensures accurate alignment of the adherends.

In order to produce a bond of well-defined shape and length, strips of steel or PTFE of thickness 1,5 mm shall be inserted in the gaps between the adherends after the application of the adhesive and prior to curing. They shall be removed after the adhesive has cured. If steel strips are used, they shall be coated with a release agent.

NOTE It is recommended that such strips have a 45° tapered edge so that a triangular fillet is formed at the end of the bond. This fillet reduces the strain concentration at the end of the bond which can extend the life of the test specimen.

6.2 Number of specimens

At least five specimens shall be tested for a given adhesive.

Dimensions in millimetres

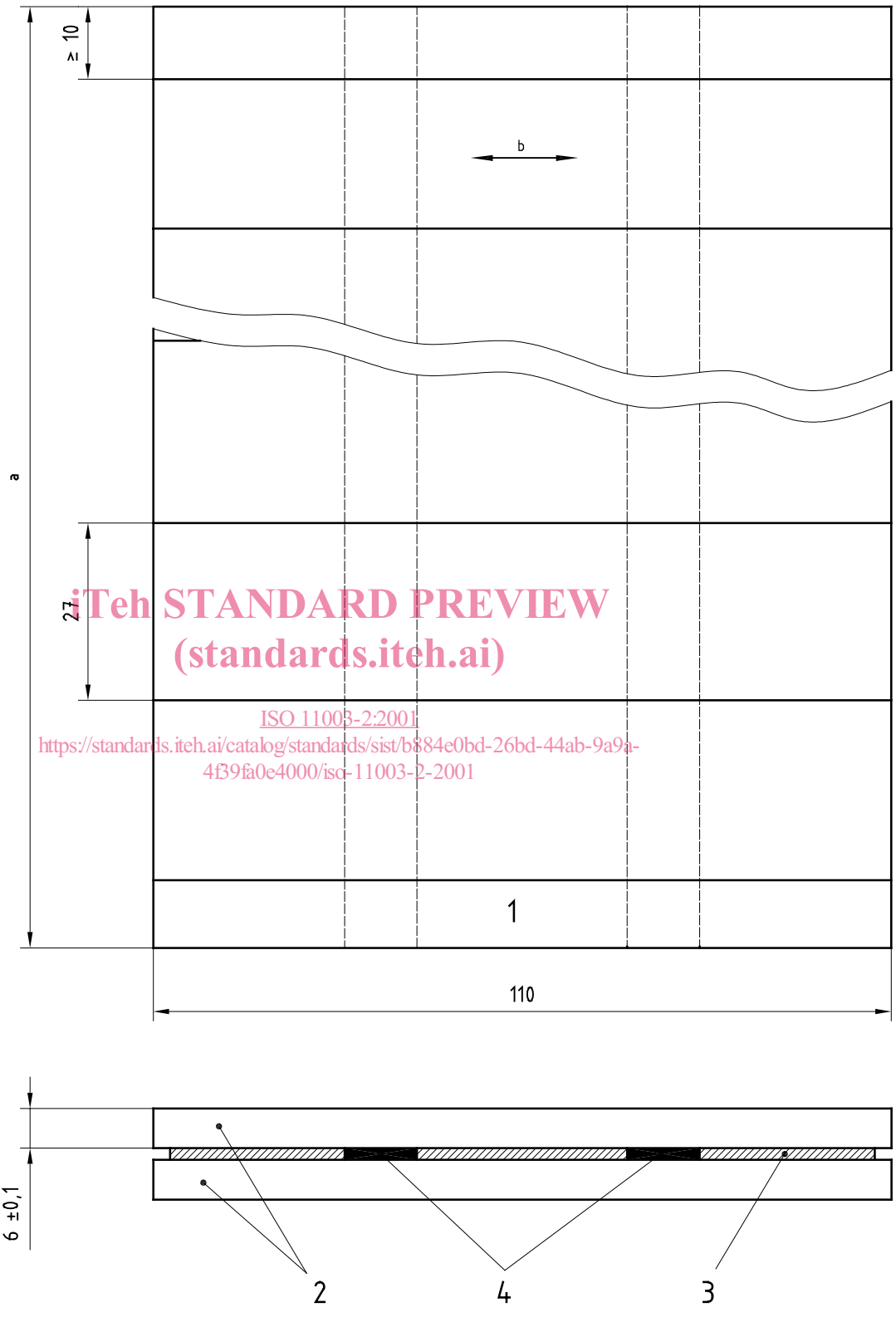

Figure 4 — Uncut panel for making specimen assemblies