**Textiles — Test methods for nonwovens —
Part 11:
Run-off**

Textiles — Méthodes d'essai pour nontissés —

Partie 11: Écoulement sur plan incliné

iTeh STANDARD PREVIEW
(standards.iteh.ai)

ISO 9073-11:2002

<https://standards.iteh.ai/catalog/standards/sist/a552d966-4210-4c78-bdff-9e0b58835df8/iso-9073-11-2002>



PDF disclaimer

This PDF file may contain embedded typefaces. In accordance with Adobe's licensing policy, this file may be printed or viewed but shall not be edited unless the typefaces which are embedded are licensed to and installed on the computer performing the editing. In downloading this file, parties accept therein the responsibility of not infringing Adobe's licensing policy. The ISO Central Secretariat accepts no liability in this area.

Adobe is a trademark of Adobe Systems Incorporated.

Details of the software products used to create this PDF file can be found in the General Info relative to the file; the PDF-creation parameters were optimized for printing. Every care has been taken to ensure that the file is suitable for use by ISO member bodies. In the unlikely event that a problem relating to it is found, please inform the Central Secretariat at the address given below.

iTeh STANDARD PREVIEW
(standards.iteh.ai)

ISO 9073-11:2002

<https://standards.iteh.ai/catalog/standards/sist/a552d966-4210-4c78-bdff-9e0b58835df8/iso-9073-11-2002>

© ISO 2002

All rights reserved. Unless otherwise specified, no part of this publication may be reproduced or utilized in any form or by any means, electronic or mechanical, including photocopying and microfilm, without permission in writing from either ISO at the address below or ISO's member body in the country of the requester.

ISO copyright office
Case postale 56 • CH-1211 Geneva 20
Tel. + 41 22 749 01 11
Fax + 41 22 749 09 47
E-mail copyright@iso.ch
Web www.iso.ch

Printed in Switzerland

Contents

Page

Foreword	iv
1 Scope	1
2 Normative references	1
3 Terms and definitions	1
4 Test I – Basic method for testing hydrophilic nonwovens	2
5 Test II – Repeated test	6
6 Test III – Modified method for testing hydrophobic nonwovens.....	8
Annex A (informative) Other characteristics.....	10

iTeh STANDARD PREVIEW
(standards.iteh.ai)

[ISO 9073-11:2002](https://standards.iteh.ai/catalog/standards/sist/a552d966-4210-4c78-bdff-9e0b58835df8/iso-9073-11-2002)

<https://standards.iteh.ai/catalog/standards/sist/a552d966-4210-4c78-bdff-9e0b58835df8/iso-9073-11-2002>

Foreword

ISO (the International Organization for Standardization) is a worldwide federation of national standards bodies (ISO member bodies). The work of preparing International Standards is normally carried out through ISO technical committees. Each member body interested in a subject for which a technical committee has been established has the right to be represented on that committee. International organizations, governmental and non-governmental, in liaison with ISO, also take part in the work. ISO collaborates closely with the International Electrotechnical Commission (IEC) on all matters of electrotechnical standardization.

International Standards are drafted in accordance with the rules given in the ISO/IEC Directives, Part 3.

The main task of technical committees is to prepare International Standards. Draft International Standards adopted by the technical committees are circulated to the member bodies for voting. Publication as an International Standard requires approval by at least 75 % of the member bodies casting a vote.

Attention is drawn to the possibility that some of the elements of this part of ISO 9073 may be the subject of patent rights. ISO shall not be held responsible for identifying any or all such patent rights.

ISO 9073-11 was prepared by Technical Committee ISO/TC 38, *Textiles*.

ISO 9073 consists of the following parts, under the general title *Textiles – Test methods for nonwovens*:

- *Part 1: Determination of mass per unit area*
- *Part 2: Determination of thickness*
- *Part 3: Determination of tensile strength and elongation*
- *Part 4: Determination of tear resistance*
- *Part 6: Absorption*
- *Part 7: Determination of bending length*
- *Part 8: Determination of liquid strike-through time (simulated urine)*
- *Part 9: Determination of drape coefficient*
- *Part 10: Generation of lint and other particles in the dry state*
- *Part 11: Run-off*
- *Part 12: Demand absorbency*

Annex A of this part of ISO 9073 is for information only.

Textiles — Test methods for nonwovens —

Part 11: Run-off

1 Scope

This part of ISO 9073 describes test methods for measuring the quantity of test liquid (simulated urine) which runs down a nonwoven test piece when a specified mass of test liquid is poured on to the nonwoven test piece superimposed on a standard absorbent media and placed on an inclined plane.

This test method is designed to compare run-off of nonwovens. It is not intended to simulate in-use conditions of finished products.

Three alternative methods are described:

- a) Test I — the basic method for testing hydrophilic nonwovens;
- b) Test II — the repeated test, with the same test parameters as in a);
- c) Test III — the modified method for testing hydrophobic nonwovens specifying another table inclination than in a).

2 Normative references

The following normative documents contain provisions which, through reference in this text, constitute provisions of this part of ISO 9073. For dated references, subsequent amendments to, or revisions of, any of these publications do not apply. However, parties to agreements based on this part of ISO 9073 are encouraged to investigate the possibility of applying the most recent editions of the normative documents indicated below. For undated references, the latest edition of the normative document referred to applies. Members of ISO and IEC maintain registers of currently valid International Standards.

ISO 139:1973, *Textiles — Standard atmospheres for conditioning and testing*

ISO 186:2002, *Paper and board — Sampling to determine average quality*

ISO 3696:1987, *Water for analytical laboratory use — Specification and test methods*

ISO 9073-6:2000, *Textiles — Test methods for nonwovens — Part 6: Absorption*

ISO 9073-8:1995, *Textiles — Test methods for nonwovens — Part 8: Determination of liquid strike-through time (simulated urine)*

3 Terms and definitions

For the purposes of this International Standard, the following terms and definitions apply.

3.1

run-off

quantity of excess liquid, in grams, that runs from the test piece

3.2

percent run-off

mass of the run-off liquid, expressed as a percentage of the original mass of liquid delivered

4 Test I – Basic method for testing hydrophilic nonwovens

4.1 Principle

A specified quantity of simulated urine is discharged at a prescribed rate under specified conditions on to a test piece of nonwoven that is superimposed on a standard absorbent media and placed on an inclined table. Any excess liquid that runs down the test piece is collected by a standard receiver pad placed below the lower end of the nonwoven test piece.

The run-off measures the mass of liquid collected by the standard receiver pad.

4.2 Apparatus

4.2.1 Run-off table, of acrylic glass or similar material as shown in Figure 1, the plane of which can be adjusted to the required angle.

The table is inclined at 25° and marked with two reference black lines at 250,0 mm ± 0,2 mm distance (see Figure 2).

The lower line (3,0 mm ± 0,2 mm from the lower end of the table) defines the position of the lower end of the absorbent medium; the upper line (approximately 25 mm from the upper end of the test piece) defines the position of the discharge tube axis.

4.2.2 Clip, or similar with symmetrical reference marks at 140,0 mm ± 0,2 mm (to adjust the axial position of the test pieces).

4.2.3 Spirit level, to ensure axial discharge of the tube.

4.2.4 Support, for placing the standard receiver pad below the lower end of the test piece.

4.2.5 Standard absorbent medium, having the characteristics given below and consisting of two layers of reference filter paper each (140 ± 1) mm × (275 ± 1) mm with the longer side in the machined direction (MD).

Mass per unit area = 124 g/m² ± 6 g/m²

LAC = 500 % ± 30 %;

STT = 3,0 s ± 0,5 s.

where

LAC is the liquid absorptive capacity measured in accordance with ISO 9073-6;

STT is the strike-through time measured without the nonwoven test piece in accordance with ISO 9073-8.

The filter papers are placed smooth/test sides up. (The smooth/test side is determined and indicated by the producer label, it is generally the side in contact with the conveyor wire during the production process, where the wire mark may be visible).

4.2.6 Standard receiver pad, of absorbent paper (same dimensions as the absorbent media) to collect excess test liquid that runs down the test piece, e.g. two filter papers (4.2.5) or similar.

NOTE The receiver pad can be replaced by a receiver trough (see note in 6.2).

4.2.7 Simulated urine, consisting of a 9 g/l solution of sodium chloride in grade 3 water conforming to ISO 3696, with a surface tension of (70 ± 2) mN/m at (20 ± 2) °C.

This surface tension is checked before each series of tests, as surface tension can alter during storage. Use at a temperature of (20 ± 2) °C.

4.2.8 Glass tube, of internal diameter 5 mm.

Dimensions in millimetres

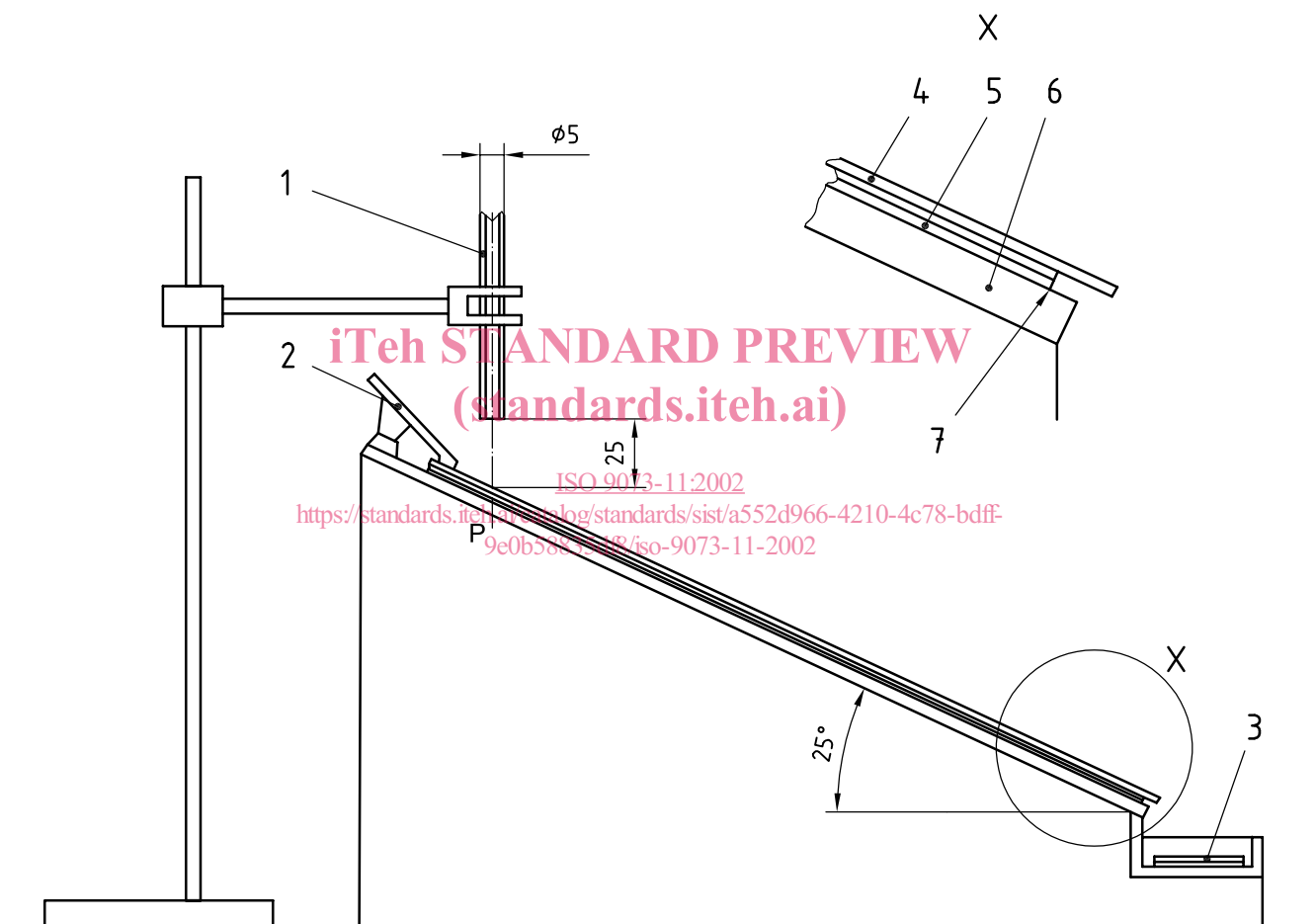

Key

- 1 Glass tube
- 2 Clip
- 3 Receiver pad
- 4 Nonwoven test piece
- 5 Absorbent medium
- 6 Run-off table
- 7 Lower reference line

Figure 1 — Run-off apparatus

Dimensions en millimètres

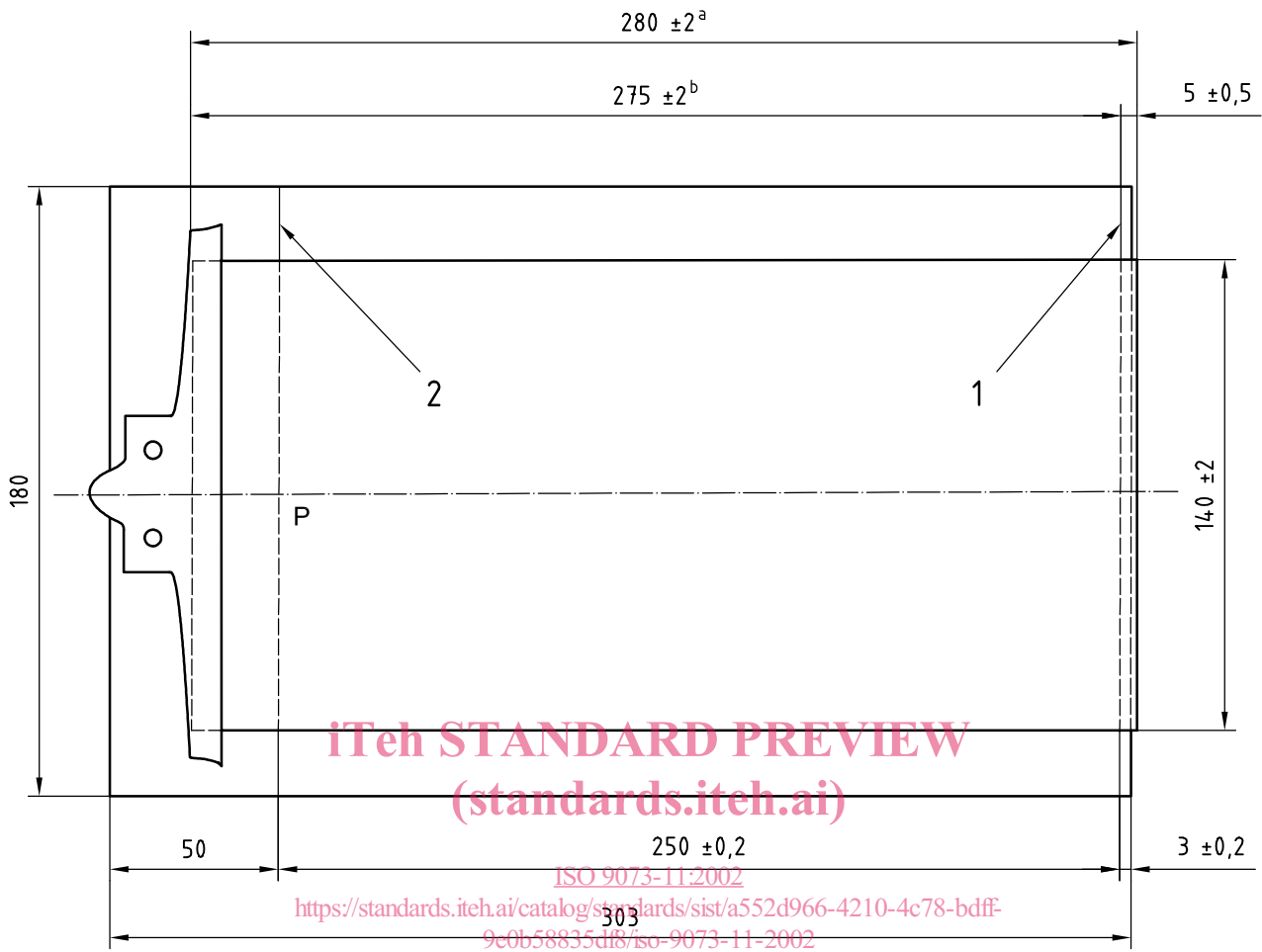

Key

- 1 Lower reference line
- 2 Upper reference line
- a Sample
- b Absorbent medium

Figure 2 — Run-off table (scale 1:2)

4.2.9 Ring stand.

4.2.10 Dosing equipment, leak-free, attached to the glass tube (4.2.8) and capable of delivering $(25,0 \pm 0,5)$ g mass of test liquid (4.2.7) in a continuous stream *via* the glass tube within $(4,0 \pm 0,1)$ s; consisting of a funnel or a syringe with either a motorized syringe drive unit, a hydraulic pump or any other pressurized system,

NOTE If the dosing device graduation is expressed as a volume (in ml), the liquid density for converting g to ml should be calculated.

4.2.11 Timer, capable of measuring 60 s to an accuracy of 0,1 s.

4.2.12 Analytical balance, capable of determining a mass of 30 g to an accuracy of 0,01 g.

4.2.13 Rigid 25° angle template.

4.3 Sampling

Sampling shall be carried out in accordance with ISO 186.

4.4 Preparation and conditioning of test pieces

4.4.1 Cut a minimum of 5 test pieces of the nonwoven, (140 ± 2) mm \times (280 ± 2) mm, with the longest side in machined direction (MD).

4.4.2 The test pieces shall be conditioned as specified in ISO 139.

4.5 Procedure

4.5.1 Adjust the angle of the table inclination to $(25^\circ \pm 10')$.

4.5.2 Use the spirit level (4.2.3) to ensure the top edge of the table is horizontal.

4.5.3 Set the dosing equipment for a discharge of $(25,0 \pm 0,5)$ g in $(4,0 \pm 0,1)$ s.

Verify regularly that the specified mass of liquid is being delivered by performing the following test.

Hold a clean dry pre-weighed cylinder capable of containing $(25 \pm 0,5)$ g of liquid under the glass tube (4.2.8). Activate the timer (4.2.11), collect and weigh the test liquid dispensed. If the mass dispensed is outside the limit $(25 \pm 0,5)$ g, adjust the flow by modifying the speed of the motor using the pump control box (see 4.2.10) and repeat the test. Continue testing and adjusting until at least three successive collections are within the specified limits.

4.5.4 Position the ring stand (4.2.9) and the glass tube vertically with the outlet about 27 mm above the run-off table (4.2.1), at the centre of the upper reference line.

4.5.5 Place the standard absorbent medium (4.2.5) on the table with the filter papers' test sides up, just covering the lower reference line.

4.5.6 Handle all test pieces at the corners so as to avoid contamination of the test area.

4.5.7 Place the nonwoven test piece, test side up, on the absorbent media so that it overlaps the filter paper at the lower end, by (5 ± 1) mm.

4.5.8 Fix the absorbent medium and nonwoven with the clip (4.2.2) centered between axial position marks (see 4.2.1).

4.5.9 Adjust the vertical distance between the glass tube (4.2.8) and the test piece to (25 ± 1) mm.

4.5.10 Weigh the standard receiver pad (4.2.6) to an accuracy of 0,01 g and record the mass (m_1).

4.5.11 Place the receiver pad on its support (4.2.4).

4.5.12 Start the discharge of test liquid (4.2.7).

4.5.13 Wait for 5 s after the discharge is completed.

4.5.14 Weigh the standard receiver pad with the collected run-off liquid and record the mass (m_2) to an accuracy of 0,01 g.

4.5.15 Make sure the run-off table is completely dry before placing the next test piece and new absorbent medium on it.

4.5.16 Repeat the run-off test steps 4.5.3 to 4.5.15 for the remaining test pieces.