

---

---

**Road vehicles — Connectors for the  
electrical connection of towing and towed  
vehicles —**

Part 1:

**Connectors for braking systems and  
running gear of vehicles with 24 V  
nominal supply voltage**

iTeh STANDARD REVIEW  
(standards.iteh.ai)

*Véhicules routiers — Connecteurs pour liaisons électriques entre  
véhicules tracteurs et véhicules tractés —*

<https://standards.iteh.ai/catalog/standards/sist/4c961af6-3266-47ad-b2e9-8a450e0290-3203>

*Partie 1: Connecteurs pour les équipements de freinage et les organes  
de roulement des véhicules à tension nominale de 24 V*



**PDF disclaimer**

This PDF file may contain embedded typefaces. In accordance with Adobe's licensing policy, this file may be printed or viewed but shall not be edited unless the typefaces which are embedded are licensed to and installed on the computer performing the editing. In downloading this file, parties accept therein the responsibility of not infringing Adobe's licensing policy. The ISO Central Secretariat accepts no liability in this area.

Adobe is a trademark of Adobe Systems Incorporated.

Details of the software products used to create this PDF file can be found in the General Info relative to the file; the PDF-creation parameters were optimized for printing. Every care has been taken to ensure that the file is suitable for use by ISO member bodies. In the unlikely event that a problem relating to it is found, please inform the Central Secretariat at the address given below.

**iTeh STANDARD PREVIEW**  
**(standards.iteh.ai)**

ISO 7638-1:2003

<https://standards.iteh.ai/catalog/standards/sist/4c961af6-3266-47ad-b2e9-8a25dc01e61a/iso-7638-1-2003>

© ISO 2003

All rights reserved. Unless otherwise specified, no part of this publication may be reproduced or utilized in any form or by any means, electronic or mechanical, including photocopying and microfilm, without permission in writing from either ISO at the address below or ISO's member body in the country of the requester.

ISO copyright office  
Case postale 56 • CH-1211 Geneva 20  
Tel. + 41 22 749 01 11  
Fax + 41 22 749 09 47  
E-mail [copyright@iso.org](mailto:copyright@iso.org)  
Web [www.iso.org](http://www.iso.org)

Published in Switzerland

**Contents**

Page

Foreword .....	iv
1 Scope .....	1
2 Normative references .....	1
3 Terms and definitions .....	2
4 Dimensional characteristics .....	2
5 Application of the connector .....	2
6 Tests and specific requirements .....	8

**iTeh STANDARD PREVIEW**  
**(standards.iteh.ai)**

ISO 7638-1:2003

<https://standards.iteh.ai/catalog/standards/sist/4c961af6-3266-47ad-b2e9-8a25dc01e61a/iso-7638-1-2003>

## Foreword

ISO (the International Organization for Standardization) is a worldwide federation of national standards bodies (ISO member bodies). The work of preparing International Standards is normally carried out through ISO technical committees. Each member body interested in a subject for which a technical committee has been established has the right to be represented on that committee. International organizations, governmental and non-governmental, in liaison with ISO, also take part in the work. ISO collaborates closely with the International Electrotechnical Commission (IEC) on all matters of electrotechnical standardization.

International Standards are drafted in accordance with the rules given in the ISO/IEC Directives, Part 2.

The main task of technical committees is to prepare International Standards. Draft International Standards adopted by the technical committees are circulated to the member bodies for voting. Publication as an International Standard requires approval by at least 75 % of the member bodies casting a vote.

Attention is drawn to the possibility that some of the elements of this document may be the subject of patent rights. ISO shall not be held responsible for identifying any or all such patent rights.

ISO 7638-1 was prepared by Technical Committee ISO/TC 22, *Road vehicles*, Subcommittee SC 3, *Electrical and electronic equipment*.

This second edition cancels and replaces the first edition (ISO 7638-1:1997), which has been technically revised taking into account the very latest revisions of ISO 4009 and ISO 4091.

ISO 7638 consists of the following parts, under the general title *Road vehicles — Connectors for the electrical connection of towing and towed vehicles*:

- *Part 1: Connectors for braking systems and running gear of vehicles with 24 V nominal supply voltage*
- *Part 2: Connectors for braking systems and running gears of vehicles with 12 V nominal supply voltage*

# Road vehicles — Connectors for the electrical connection of towing and towed vehicles —

## Part 1: Connectors for braking systems and running gear of vehicles with 24 V nominal supply voltage

### 1 Scope

This part of ISO 7638 gives the dimensions of, and specifies the contact allocation and tests and test requirements for, connectors for the electrical connection of the braking systems and running gear of towing and towed vehicles with 24 V nominal supply voltage. In addition, it specifies a park socket used to receive and store the plug when disconnected.

### 2 Normative references

The following referenced documents are indispensable for application of this document. For dated references, only the edition cited applies. For undated references, the latest edition of the referenced document (including any amendments) applies.

ISO 4009, *Commercial vehicles — Location of electrical and pneumatic connections between towing vehicles and trailers*

ISO 4091, *Road vehicles — Connectors for the electrical connection of towing vehicles and towed vehicles — Definitions, tests and requirements*

ISO 4141 (all parts), *Road vehicles — Multi-core connecting cables*

ISO 7638-2, *Road vehicles — Connectors for the electrical connection of towing and towed vehicles — Part 2: Connectors for braking systems and running gear of vehicles with 12 V nominal supply voltage*

ISO 11992-1, *Road vehicles — Interchange of digital information on electrical connections between towing and towed vehicles — Part 1: Physical layer and data-link layer*

ISO 11992-2, *Road vehicles — Interchange of digital information on electrical connections between towing and towed vehicles — Part 2: Application layer for brakes and running gear*

ISO 12098<sup>1)</sup>, *Road vehicles — Connectors for the electrical connection of towing and towed vehicles — 15-pole connector for vehicles with 24 V nominal supply voltage*

---

1) To be published. (Revision of ISO 12098:1994)

### 3 Terms and definitions

For the purposes of this document, the terms and definitions given in ISO 4091 apply.

### 4 Dimensional characteristics

#### 4.1 General

Details not specified are at the manufacturer's discretion.

The contacts shall be floating and shall align to the datum position when plug and socket are engaged.

#### 4.2 Plug

Dimensions of the plug shall be in accordance with Figure 1. The locking lever design shall take into consideration the space required for screws used to fasten the socket (see Figure 2).

#### 4.3 Socket

Dimensions of the socket shall be in accordance with Figure 2. The cover is shown in the open position: it shall close automatically when the plug is disconnected.

#### 4.4 Park socket

Dimensions of the park socket shall be in accordance with Figure 3. The cover is shown in the open position: it shall close automatically when the plug is disconnected.

iTeh STANDARD PREVIEW

(standards.iteh.ai)

ISO 7638-1:2003

<https://standards.iteh.ai/catalog/standards/sist/4c961af6-3266-47ad-b2e9-8a25dc01e61a/iso-7638-1-2003>

### 5 Application of the connector

#### 5.1 General

The coiled cable assembly is fitted to the semi-trailer towing vehicle (fifth-wheel tractor) and may be connected to the electrical on-board network of the towing vehicle with or without the connection (see Figure 4).

The uncoiled cable assembly is fitted to the drawbar trailer. Therefore, the trailer towing vehicle (drawbar tractor) shall be fitted with a socket mounted at the rear of the vehicle (see Figure 4).

#### 5.2 Connector positions and free space

The positions of, and free space around, the connectors shall be in accordance with ISO 4009.

Dimensions in millimetres

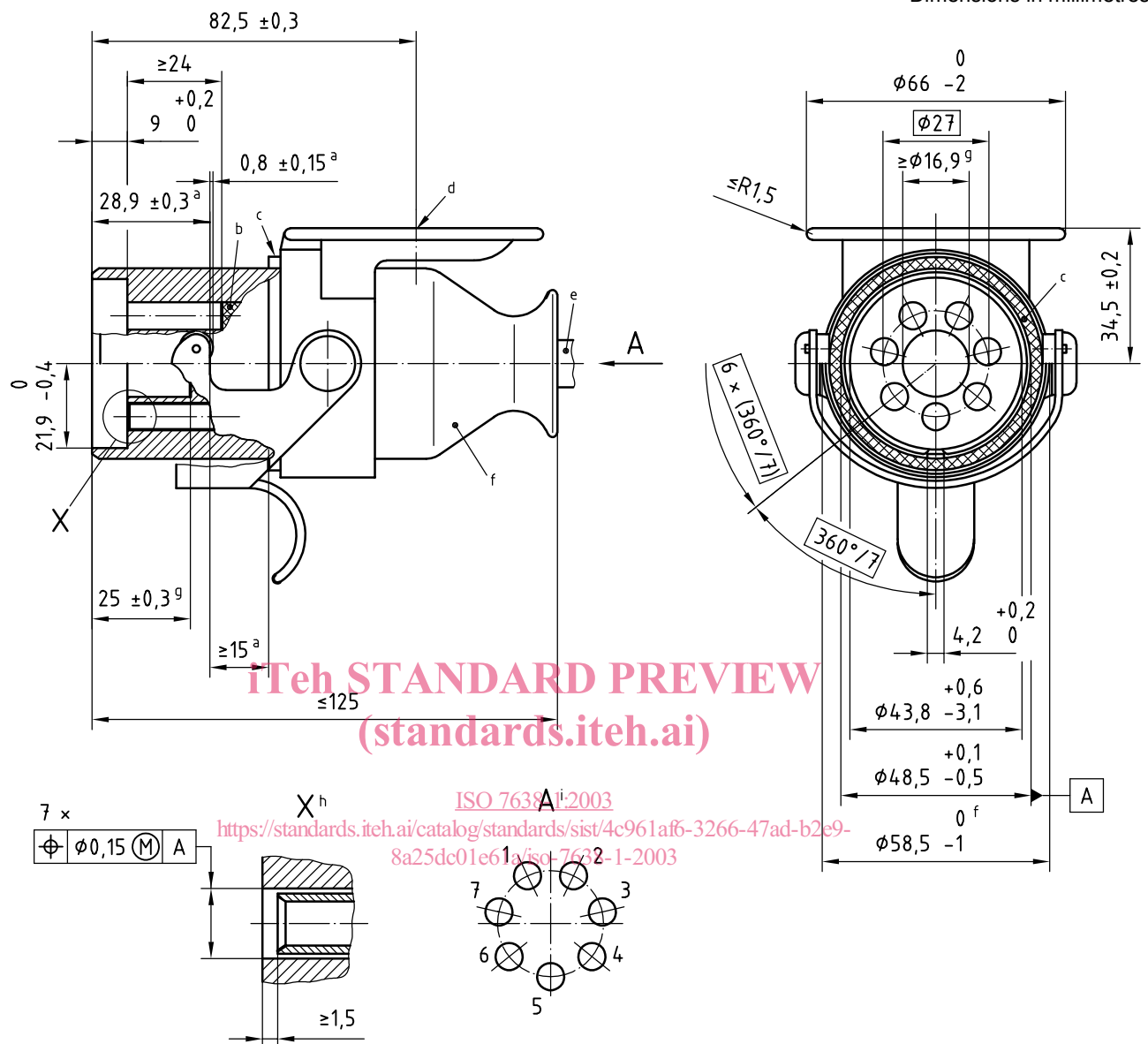

- a Dimension refers to the locking lever in its locked position.
- b If Contacts 6 and 7 are not used, blanking plugs shall be inserted to accept later fitment of that pins and tubes.
- c The sealing ring shall be mounted such that it cannot become detached under normal use.
- d Centre of cover rest.
- e See ISO 4141-3.
- f Other housing designs are permitted provided they are in compliance with the maximum distance of 58 mm for the locking lever.
- g Minimum space required for the ejection from the socket.
- h Spring tube.
- i Contact numbers.

Figure 1 — Plug





- a The sealing ring shall be mounted such that it cannot become detached under normal use.
- b For existing products for which the cable outlet is mounted from the rear, the outside diameter of the outlet may be larger with the vehicle manufacturer's agreement. However, to ensure socket exchangeability, future applications should have a maximum outside diameter of 54 mm over a maximum length of 75 mm.
- c Opening angle  $\geq 120^\circ$ .
- d Reference point for engaged locking lever.
- e Ejector.
- f Minimum space required for screws used to fasten the socket.
- g If Contacts 6 and 7 are not used, blanking plugs shall, where applicable, be inserted to accept later fitment of pins and tubes. These blanks shall permit 5-pole versions to be mated with 7-pole versions.
- h This area shall be smooth and burr-free.

**Figure 2** (continued)

**iTeh STANDARD PREVIEW**  
**(standards.iteh.ai)**

ISO 7638-1:2003

<https://standards.iteh.ai/catalog/standards/sist/4c961af6-3266-47ad-b2e9-8a25dc01e61a/iso-7638-1-2003>