**Road vehicles — Connectors for the
electrical connection of towing and towed
vehicles — 7-pole connector type 24 N
(normal) for vehicles with 24 V nominal
supply voltage**

iTeh STANDARD PREVIEW
*Véhicules routiers — Connecteurs pour liaisons électriques entre
véhicules tracteurs et véhicules tractés — Connecteur à 7 contacts de
type 24 N (normal) pour les véhicules à tension nominale de 24 V*
(standards.iteh.ai)

ISO 1185:2003

<https://standards.iteh.ai/catalog/standards/sist/3531bb76-8c93-4c9c-86a4-94d36d2f12e7/iso-1185-2003>



PDF disclaimer

This PDF file may contain embedded typefaces. In accordance with Adobe's licensing policy, this file may be printed or viewed but shall not be edited unless the typefaces which are embedded are licensed to and installed on the computer performing the editing. In downloading this file, parties accept therein the responsibility of not infringing Adobe's licensing policy. The ISO Central Secretariat accepts no liability in this area.

Adobe is a trademark of Adobe Systems Incorporated.

Details of the software products used to create this PDF file can be found in the General Info relative to the file; the PDF-creation parameters were optimized for printing. Every care has been taken to ensure that the file is suitable for use by ISO member bodies. In the unlikely event that a problem relating to it is found, please inform the Central Secretariat at the address given below.

iTeh STANDARD PREVIEW
(standards.iteh.ai)

[ISO 1185:2003](#)

<https://standards.iteh.ai/catalog/standards/sist/3531bb76-8c93-4c9c-86a4-94d36d2f12e7/iso-1185-2003>

© ISO 2003

All rights reserved. Unless otherwise specified, no part of this publication may be reproduced or utilized in any form or by any means, electronic or mechanical, including photocopying and microfilm, without permission in writing from either ISO at the address below or ISO's member body in the country of the requester.

ISO copyright office
Case postale 56 • CH-1211 Geneva 20
Tel. + 41 22 749 01 11
Fax + 41 22 749 09 47
E-mail copyright@iso.org
Web www.iso.org

Published in Switzerland

Contents

Page

Foreword	iv
1 Scope	1
2 Normative references	1
3 Terms and definitions	1
4 Dimensions	1
5 Application of the connector	4
6 Tests and requirements	5
Bibliography	8

iTeh STANDARD PREVIEW
(standards.iteh.ai)

[ISO 1185:2003](https://standards.iteh.ai/catalog/standards/sist/3531bb76-8c93-4c9c-86a4-94d36d2f12e7/iso-1185-2003)

<https://standards.iteh.ai/catalog/standards/sist/3531bb76-8c93-4c9c-86a4-94d36d2f12e7/iso-1185-2003>

Foreword

ISO (the International Organization for Standardization) is a worldwide federation of national standards bodies (ISO member bodies). The work of preparing International Standards is normally carried out through ISO technical committees. Each member body interested in a subject for which a technical committee has been established has the right to be represented on that committee. International organizations, governmental and non-governmental, in liaison with ISO, also take part in the work. ISO collaborates closely with the International Electrotechnical Commission (IEC) on all matters of electrotechnical standardization.

International Standards are drafted in accordance with the rules given in the ISO/IEC Directives, Part 2.

The main task of technical committees is to prepare International Standards. Draft International Standards adopted by the technical committees are circulated to the member bodies for voting. Publication as an International Standard requires approval by at least 75 % of the member bodies casting a vote.

Attention is drawn to the possibility that some of the elements of this document may be the subject of patent rights. ISO shall not be held responsible for identifying any or all such patent rights.

ISO 1185 was prepared by Technical Committee ISO/TC 22, *Road vehicles*, Subcommittee SC 3, *Electrical and electronic equipment*.

This third edition cancels and replaces the second edition (ISO 1185:1997), which has been technically revised.

iTeh STANDARD PREVIEW
(standards.iteh.ai)

<https://standards.iteh.ai/catalog/standards/sist/3531bb76-8c93-4c9c-86a4-94d36d2f12e7/iso-1185-2003>

Road vehicles — Connectors for the electrical connection of towing and towed vehicles — 7-pole connector type 24 N (normal) for vehicles with 24 V nominal supply voltage

1 Scope

This International Standard specifies the dimensions of, and gives particular requirements for, 7-pole connectors of type 24 N and their contact allocation for the electrical connection of towing and towed vehicles with 24 V nominal supply voltage, thus ensuring interchangeability.

NOTE For new developments and where more than 7 poles are required, as an alternative to the use of the 7-pole connector in accordance with this International Standard and ISO 3731, the use of the 15-pole connector in accordance with ISO 12098 ^[1] may be required.

2 Normative references

The following referenced documents are indispensable for application of this document. For dated references, only the edition cited applies. For undated references, the latest edition of the referenced document (including any amendments) applies.

ISO 3731, *Road vehicles — Connectors for the electrical connection of towing and towed vehicles — 7-pole connector type 24 S (supplementary) for vehicles with 24 V nominal supply voltage*

ISO 4009, *Commercial vehicles — Location of electrical and pneumatic connections between towing vehicles and trailers*

ISO 4091:2003, *Road vehicles — Connectors for the electrical connection of towing and towed vehicles — Definitions, tests and requirements*

ISO 4141 (all parts), *Road vehicles — Multi-core connecting cables*

3 Terms and definitions

For the purposes of this document, the terms and definitions given in ISO 4091 apply.

4 Dimensions

4.1 General

Details not specified are at the manufacturer's discretion.

4.2 Plug

Dimensions shall be in accordance with Figure 1.

The plug shall have six spring tubes, numbered 2 to 7, corresponding to Pin Nos. 2 to 7 of the socket, and one large spring tube, No. 1, corresponding to Pin No. 1 of the socket.

Dimensions in millimetres

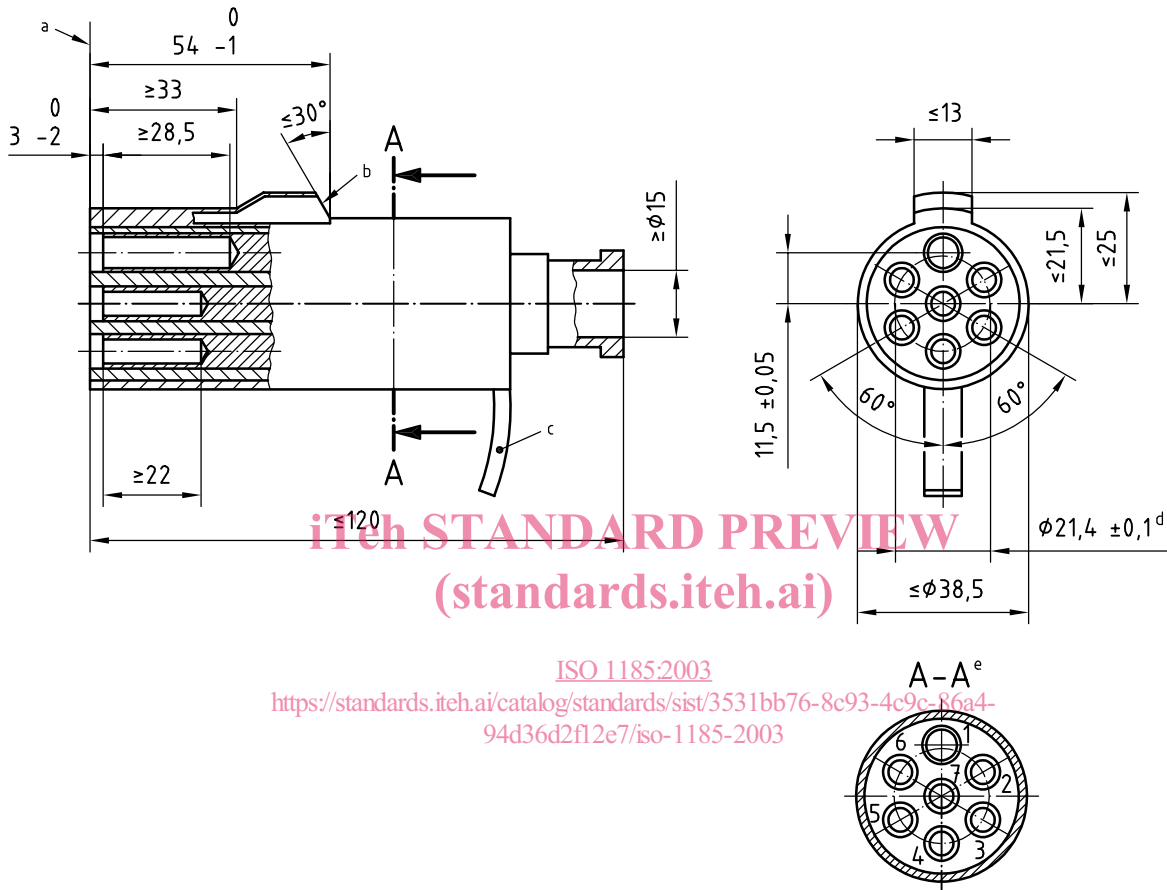

- a Reference plane.
- b Locking collar.
- c Handle downwards or to right and left, at the discretion of the manufacturer.
- d Pitch circle diameter.
- e Rear view of the terminals.

Figure 1 — Plug

4.3 Socket

Dimensions shall be in accordance with Figure 2. The socket shall have six pins, numbered 2 to 7, and one larger pin, No. 1.

Dimensions in millimetres

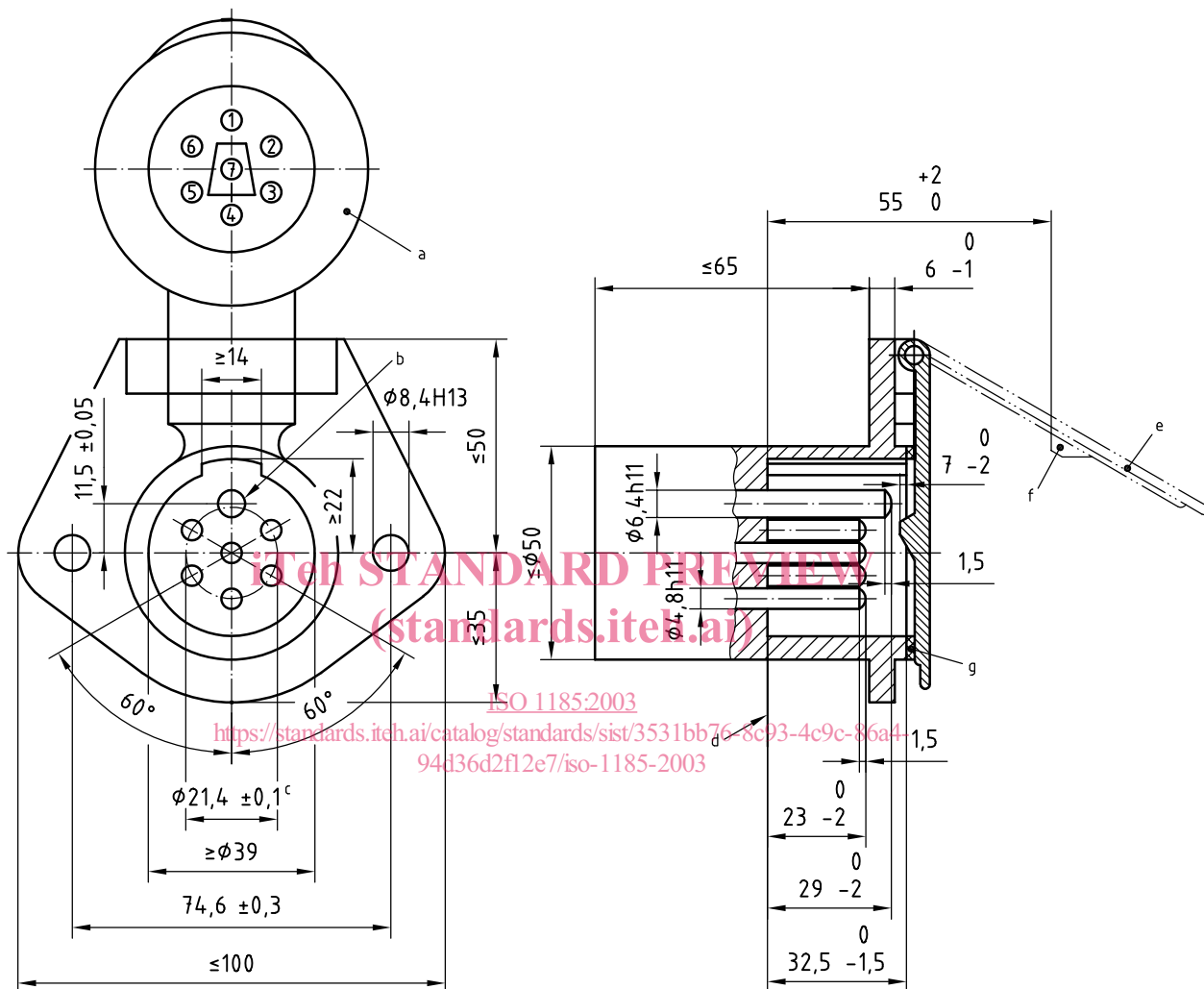

- a Cover drawn in the open position.
- b Contact No. 1.
- c Pitch circle diameter.
- d Reference plane.
- e Position of the cover with plug introduced.
- f Locking lug.
- g Sealing ring.

Figure 2 — Socket

5 Application of the connector

5.1 General

The coiled cable assembly is fitted to the semi-trailer towing vehicle (fifth wheel tractor) and may be connected to the electrical on-board network of the towing vehicle with or without the connection (see Figure 3).

The uncoiled cable assembly is fitted to the drawbar trailer. Therefore, the trailer towing vehicle (drawbar tractor) shall be fitted with a socket mounted at the rear of the vehicle (see Figure 3).

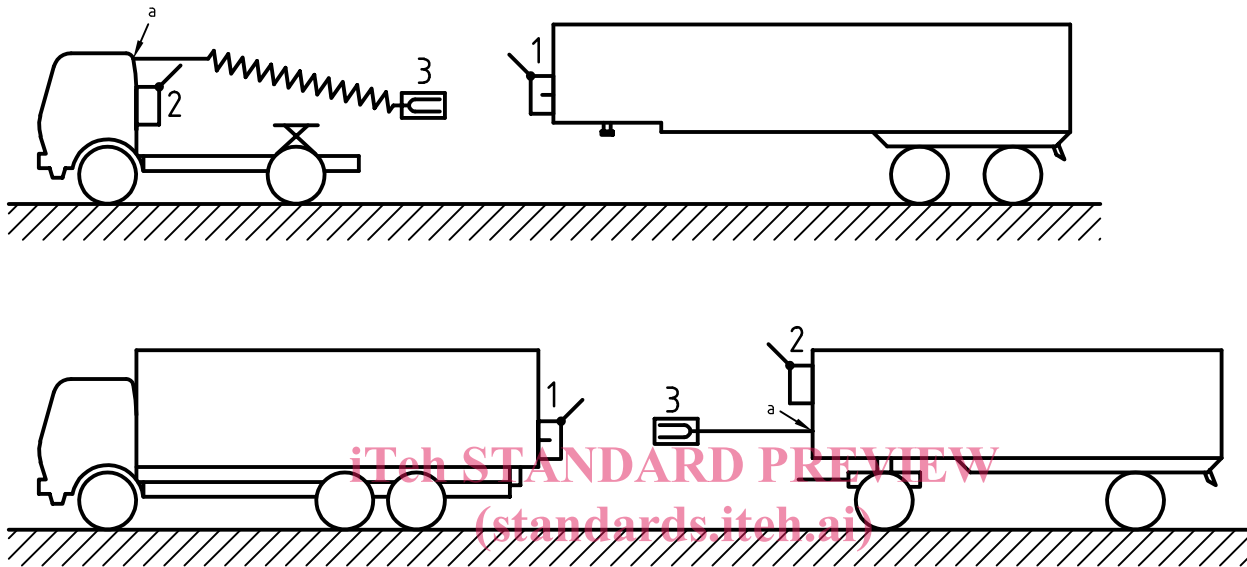

Key

- 1 socket
- 2 park socket
- 3 plug
- a See 5.1.

<https://standards.itech.ai/catalog/standards/sist/3531bb76-8c93-4c9c-86a4-94d36d2f12e7/iso-1185-2003>
 ISO 1185:2003

Figure 3 — Electrical connection positions

5.2 Distinguishing marking

The 24 N connectors shall be distinguished from 24 S connectors (see ISO 3731) by means of a different colouring of at least the insulating parts. A dark and permanent colour, preferably black, shall be used for the 24 N connector.

5.3 Connector positions and free space

The positions of, and free space around, the connectors shall be in accordance with ISO 4009.

5.4 Contact allocation

The allocation of the seven contacts shall be in accordance with Table 1.

Table 1 — Contact allocation

Contact No.	Function	Core insulation colour (for information)
1	Common return	White
2	Left-hand rear position and marker lights, and rear registration plate illumination device ^a	Black
3	Left-hand direction indicator light	Yellow
4	Stop lights	Red
5	Right-hand direction indicator light	Green
6	Right-hand rear position and marker lights, and rear registration plate illumination device ^a	Brown
7	Braking control for trailers	Blue

^a The rear registration plate illumination device shall be connected such that no lamp of the device has a common connection to both contacts 2 and 6.

5.5 Contact designation

The contact designation numbers shall be permanently marked on the inside of the socket cover, and on the terminal faces of both plug and socket.

The character size shall not be less than 2 mm. However, where limited space is available, a smaller size may be used on the terminal face.

5.6 Terminals

The terminals at the rear side of the pins and tubes shall be capable of accepting cables with the following nominal cross-sectional areas.

- Contact No. 1: 2,5 mm².
- Contact Nos. 2 to 7: 1,5 mm².

5.7 Connecting cable

The connecting cable shall meet the requirements of the applicable parts of ISO 4141.

5.8 Protection of disconnected plug

A means of storing the plug when disconnected shall be provided on the vehicle or vehicles, intended to protect the plug from the ingress of water or foreign bodies and from accidental damage.

6 Tests and requirements

6.1 General

Connectors in accordance with this International Standard shall be tested in the sequences given in Table 2; for test procedures, see ISO 4091. They shall meet the requirements of ISO 4091, except where this is specified differently in the following subclauses.