



Designation: A 888 – 03

Standard Specification for Hubless Cast Iron Soil Pipe and Fittings for Sanitary and Storm Drain, Waste, and Vent Piping Applications¹

This standard is issued under the fixed designation A 888; the number immediately following the designation indicates the year of original adoption or, in the case of revision, the year of last revision. A number in parentheses indicates the year of last reapproval. A superscript epsilon (ϵ) indicates an editorial change since the last revision or reapproval.

1. Scope

1.1 This specification covers hubless cast iron soil pipe and fittings for use in gravity flow applications. It establishes standards covering material, manufacture, mechanical and chemical properties, dimensions, coating, test methods, inspection, certification and product marking for hubless cast iron soil pipe and fittings. These pipe and fittings are intended for non-pressure applications, as the selection of the proper size for sanitary drain, waste, vent, and storm drain systems allows free air space for gravity drainage.

1.2 The EDP/ASA numbers indicated in this section represent a Uniform Industry Code adopted by the American Supply Association (ASA). A group designation prefix, 022, is assigned to hubless products, followed by the four-digit identification assigned to individual items and a check digit. This system has been instituted to facilitate EDP control through distribution channels, and be used universally in ordering and specifying product items. Those items with no EDP numbers are either new, special or transitory and will be assigned numbers on subsequent prints of this specification.

1.3 This specification covers pipe and fittings of the following patterns and applies to any other patterns that conform with the applicable requirements given herein.²

1.3.1 Lengths:

EDP/ASA Identification Numbers for Hubless Pipe
10 ft (3.0 m) in sizes and 5 ft. (1.5 m)
1½, 2, 3, 4, 5, 6, 8,
10, 12, and 15 inch.
Method of Specifying Fittings
Sample Test Bar

Figures
Fig. 1
Fig. 1, Fig. 2

Fig. 3
Fig. 4

1.3.2 Fittings:

Quarter Bend
Quarter Bend, Reducing
Quarter Bend, With Side Opening
Quarter Bend, With Heel Opening
Quarter Bend, Tapped

Fig. 5
Fig. 6
Fig. 7
Fig. 8
Fig. 9

Quarter Bend, Double	Fig. 10
Quarter Bend, Long	Fig. 11
Short Sweep	Fig. 12
Long Sweep	Fig. 13
Long Sweep, Reducing	Fig. 14
Fifth Bend	Fig. 15
Sixth Bend	Fig. 16
Eighth Bend	Fig. 17
Eighth Bend Long	Fig. 18
Sixteenth Bend	Fig. 19
Sanitary Tee	Fig. 20
Sanitary Tee With Side Opening	Fig. 21
Sanitary Tee With 2 in. Side Opening R or L/R and L	Fig. 22
Sanitary Tee, New Orleans Special With Side Opening	Fig. 23
Sanitary Tee With 45° Side Openings and New Orleans	Fig. 24
Sanitary Special Tee Tapped	Fig. 25
Sanitary Tapped Tee, Horizontal Twin	Fig. 26
Sanitary Tapped Tee, Double Vertical	Fig. 27
Y Branch	Fig. 28
Y Branch, Double	Fig. 29
Y Branch, Upright	Fig. 30
Upright Y Wide Center Florida Special	Fig. 31
Y Branch, Combination 1/8 Bend	Fig. 32
Y Branch, Combination 1/8 Bend Double	Fig. 33
Sanitary Cross	Fig. 34
Sanitary Cross With Side Opening	Fig. 35
Sanitary Cross, New Orleans, With Side Openings	Fig. 36
Sanitary Cross, New Orleans, With 45° Special and Regular Side Openings	Fig. 37
Sanitary Cross, Tapped	Fig. 38
Test Tee	Fig. 39
Tapped, Extension Piece	Fig. 40
Increaser-Reducer	Fig. 41
Increaser-Reducer, Short	Fig. 42
Tapped Adapter	Fig. 43
Blind Plug	Fig. 44
Iron Body Cleanout-Tapped	Fig. 45
P Trap	Fig. 46
P Trap, Long	Fig. 47
P Trap, Long-Tapped	Fig. 48
P Trap, Deep Seal	Fig. 49
P Trap, Reducing	Fig. 50
P Trap, With Primer	Fig. 51
P Trap, With Tapped Inlet	Fig. 52
Hub Adapter	Fig. 53
Tapped Inlet, Double	Fig. 54
Modified Combination Wye and 1/8 Bend, Double	Fig. 55
Modified Combination Wye and 1/8 Bend, Double, Extended	Fig. 56
Regular or Extended Left or Right Regular or Extended Double	Fig. 57
Regular or Extended Left or Right Regular or Extended Double	Fig. 58
Two-Way Cleanout	Fig. 59
Twin Cleanout	Fig. 60
Closet Bend, Regular and Reducing	Fig. 61
Closet Flange	Fig. 62

¹ This specification is under the jurisdiction of ASTM Committee A04 on Iron Castings and is under the direct responsibility of Subcommittee A04.12 on Pipes and Tubes.

Current edition approved July 10, 2003. Published September 2003. Originally approved in 1990. Last previous edition approved in 1998 as A 888 – 98^{ε1}.

² Reprinted with permission from Cast Iron Soil Pipe Institute.

Tapping Bosses

Fig. 63

1.4 The values stated in inch-pound units shall be regarded as the standard. The values given in parentheses shall be for information only. Metric conversions in Table 1 and Table 2 are to two decimal places; all other metric conversions are rounded to the nearest whole number.

1.5 The committee with jurisdiction over this standard is aware of another comparable standard published by the Cast Iron Soil Pipe Institute, CISPI 301.

NOTE 1—The text of this standard references notes and footnotes which provide explanatory material. These notes and footnotes (excluding those in tables and figures) shall not be considered as requirements of the standard.

2. Referenced Documents

2.1 ASTM Standards:

- A 48 Specification for Gray Iron Castings³
- A 644 Terminology Relating to Iron Castings³
- C 564 Specification for Rubber Gaskets for Cast Iron Soil Pipe and Fittings⁴
- E 8 Test Methods for Tension Testing of Metallic Materials⁵

2.2 Federal Standard:

- Fed. Std. No. 123 Marking for Shipment (Civil Agencies)⁶

2.3 Military Standard:

- MIL-STD-129 Marking for Shipment and Storage⁶

2.4 ANSI/ASME Standard:

- B2.1 Pipe Threads⁷

2.5

Handbook 28, Screw Thread Standards for Federal Services⁸

2.6 Other Documents:

- Uniform Freight Classification Rules⁹
- National Motor Freight Classification Rules¹⁰
- Cast Iron Soil Pipe Institute (CISPI) Specification 301¹¹

3. Terminology

3.1 Abbreviations:

- 3.2 AC—above center
- ADAPTR—adapter
- &—and
- ASA—American Supply Association
- ASSY—assembly
- BD—bend
- CARL—Carlson

- CF—Carlson fitting
- CLO—closet
- CO—cleanout
- COMB—combination
- CRS—cross
- DB—double
- DBL—double
- EDP—electronic data processing
- EXT—extended, extension
- F—figure
- FER—ferrule
- FLNG—flange
- FTG—fitting
- HI—high
- HOR—horizontal
- INC—increaser, increasing
- L—left hand
- L/—less
- LG—long
- LH—left hand
- LNG—long
- /MAIN—on main
- MN—on main
- NO—New Orleans
- R—right hand
- RAD—radius
- RED—reducer, reducing
- REV—revent
- RH—right hand
- SAN—sanitary
- SD—side
- SL & NOTCH—slotted and notched
- SO—side openings
- ST—sanitary tap
- T—tee
- TAP—tap, tapped
- TOT—tap on top
- TP—tap, tapped
- V—vent
- VERT—vertical
- W/—with
- Y—wye

3.3 Definitions of Terms Specific to This Standard:

3.3.1 *manufacturer*—the entity that casts the pipe and fittings covered by this standard.

4. Materials and Manufacture

4.1 The pipe and fittings shall be iron castings suitable for installation and service for sanitary drain, waste, and vent piping applications. They shall meet all applicable requirements and tests given herein.

4.2 The castings shall be made of cast iron, produced by an established commercial method that provides adequate control over chemical and mechanical properties.

4.3 Cast iron is a generic term for a series of alloys as defined in Terminology A 644, and it includes gray iron as well as ductile iron. The castings shall be sound, true to pattern, and of compact close grain that permits drilling and cutting by ordinary methods. The interior surface shall be reasonably

³ Annual Book of ASTM Standards, Vol 01.02.

⁴ Annual Book of ASTM Standards, Vol 04.07.

⁵ Annual Book of ASTM Standards, Vol 03.01.

⁶ Available from Standardization Documents, Order Desk, Building 4, Section D, 700 Robbins Ave., Philadelphia, PA 19111-5094, Attn: NPODS.

⁷ Available from the American National Standards Institute, 25 W. 43rd St., 4th Floor, New York, NY 10036.

⁸ Available from National Institute of Standards and Technology, U.S. Department of Commerce, Gaithersburg, MD 20899.

⁹ Available from the Uniform Classification Commission, Room 1106, 222 S. Riverside Plaza, Chicago, IL 60606.

¹⁰ Available from National Motor Freight Inc., 1616 P. St., N. W., Washington, DC 20036.

¹¹ Available from Cast Iron Soil Pipe Institute, 5959 Shallowford Rd., Chattanooga, TN 37421.

smooth and free from defects that would make the castings unfit for the use for which they are intended.

5. Mechanical Properties

5.1 *Mechanical Tests for Gray Iron*—When requested, tests shall be performed to determine mechanical properties of the gray iron used in the manufacture of gray iron soil pipe and fittings. Either transverse (flexure) test bars or tension test specimens shall be employed.

5.1.1 *Tensile Strength Test*—The tensile strength shall be not less than 21 000 psi (145 MPa).

6. Dimensions and Permissible Variations

6.1 *Pipe:*

6.1.1 *Ends of Pipe*—The end of pipe shall be cast with or without a spigot bead. The pipe shall be cast in one piece.

6.1.2 *Dimensions of Pipe*—Pipe shall be 10 ft (3 m) long or 5 ft (1.5 m) long with the dimensions and tolerances specified in Fig. 1 and Fig. 2. (The laying length of pipe is the same as actual length.)

6.1.3 *Straightness of Pipe*—Pipe shall be straight to the extent that for 10 ft (3 m) lengths, deflections in the barrel shall not exceed 5/8 in. (16 mm). For 5 ft (1.5 m) lengths, deflections in the barrel shall not exceed 5/16 in. (8 mm).

6.2 *Fittings:*

6.2.1 *Dimensions of Fittings*—All fittings shall conform to the dimensions and tolerances specified in Fig. 1 and Fig. 2 as applicable. Fittings of the patterns specified herein shall conform to the applicable dimensions in Figs. 6-63, inclusive. Fittings not listed shall conform to Fig. 1 for wall thickness and dimension R for the minimum radius of any drain inlets that any such fittings provide.

6.2.2 *Ends of Fittings*—Ends shall have spigot beads as shown in Fig. 1 and Fig. 2. Positioning lugs shall be cast on fittings. Positioning lugs shall be as described in Fig. 2 or continuous around circumference of the fitting. Exception: where permitted in Figures 5-63, spigot beads and gasket positioning lugs shall be optional depending on casting method used. It is permissible to increase the wall thickness on the inside surface of fitting ends. The increased thickness shall not reduce the minimum B dimension in Table 1 in excess of 0.06

in and shall not extend more than 4 1/4 in from the plain end. The increased thickness shall be tapered and shall offer no obstruction to flow.

6.2.3 *Pipe Threads*—Screw plugs and tapped openings in fittings shall have taper pipe threads in accordance with ANSI/ASME Standard 2.1.

6.2.4 Internal threads shall be chamfered at the entering end approximately to the major diameter of the thread, at an angle of approximately 45° with the axis of the thread for easy entrance in making a joint and for protection of the thread. The chamfer shall be concentric with the thread and shall be included in the measurement of the thread length.

7. Methods of Specifying Fittings

7.1 *Method of Specifying Sizes of Fittings of More than One Size*—The sizes shall be designated by the order of listing, as follows:

7.1.1 *Branch and Tapped Fittings:*

7.1.1.1 *Size of Run*—The run shall be that portion of the fitting which forms part of the main pipe line.

7.1.1.2 *Size of Branch:*

7.2 *Methods of Specifying Hand of Fittings with Side Inlets*—When placed in the position described below. If the side inlet appears on the right, it shall be a right-hand fitting; if on the left, it shall be a left-hand fitting.

7.2.1 *Branch Fittings*—The branch shall be placed toward the observer and the outlet end of the run lower than the branch.

7.3 The fitting illustrated in Fig. 3 has a right-hand inlet. Left-hand fittings have these openings on the side opposite to that shown. Inlets on fittings shall be made with or without spigot bead and positioning lug.

8. Coating

8.1 The pipe and fittings shall be furnished coated. The pipe and fittings shall be uniformly coated with a material suitable for the purpose that is adherent, not brittle, and without a tendency to scale. The coating shall not contain asbestos above current MSDS reportable levels. Material safety data sheets shall be furnished by the coating manufacturer when requested. The coating shall be evenly and smoothly applied to all surfaces, except in threaded openings.

9. Sampling

9.1 Chemical and mechanical tests shall be made regularly and at sufficiently close intervals for adequate determinations of the significant chemical constituents and properties of the cast iron. Records of chemical analysis shall be maintained by the manufacturer. Copies of these analyses shall be furnished to the purchaser when requested.

9.2 A lot shall consist of one of the following:

9.2.1 All the metal poured from a single heating is a batch type furnace.

9.2.2 All the metal from two or more batch type melting furnaces poured into a single ladle or a single casting.

9.2.3 All the metal poured from a continuous melting furnace for a given period of time between changes in charge, processing conditions, or aim-for chemistry or 4 h, whichever is the shorter period.

TABLE 1 EDP Identification Numbers for Hubless Pipe

NOTE 1—When ordering by these EDP numbers, be sure to include the check (✓) digit following the item number (022 0126 7). This check digit is verification of the group and item number you select.

Manufacturer's Item	Code			Description ^A
	Group	Item No.	✓	
Hubless pipe (see Fig. 1.)	022	0156	4	10 ft (3 m) length 1 1/2
		0158	0	2 1/2
		0160	6	3
		0162	2	4
		0164	8	5
		0168	9	6
		0170	5	8
		0171	3	10
		0172	7	12
		0173	1	15

^A EDP numbers for fittings will appear in each of the respective tables.

9.2.3.1 The purchaser shall be permitted to agree to extend the 4 h time period to 8 h if the manufacturer is able to demonstrate sufficient process control to warrant such an extension.

10. Test Methods

10.1 *Gray Iron:*

10.1.1 *Tensile Strength Test*—Test bars shall be cast in accordance with the requirements of Specification A 48. The test bar dimensions and drawing are found in Fig. 4. The tensile strength shall be determined in accordance with Test Methods E 8.

10.1.2 Tension test reports shall include breaking load of test bars, machined diameter of test bar, and calculated tensile strength.

11. Inspection

11.1 *Inspection and Test by the Manufacturer*—Pipe and fittings shall be inspected to verify compliance with this standard. The manufacturer shall maintain a record of all inspections.

11.2 *Pipe Inspection*—At regular intervals (not to exceed 12 h) during the course of production, sample pieces of each size of pipe or pipes being produced shall be selected randomly for inspection. Each pipe selected shall be measured by suitable gauges and all dimensions detailed in Fig. 1 of this standard verified to comply with the requirements of this standard. The inspection records shall be maintained by the manufacturer for a period of seven years.

11.3 *Fitting Inspection*—At regular intervals (not to exceed twelve hours) during the course of production, sample pieces of each size and configuration of fitting being produced shall be selected randomly for inspection. Each fitting selected shall be measured by suitable gauges to verify that the laying length (as detailed in figures 4-76), and all applicable dimensions detailed in Fig. 1 and Fig. 2 of this standard comply with the requirements of this standard. The inspection records shall be maintained by the manufacturer for a period of seven years.

11.4 *Marking Inspection*—Inspection shall include verification that the markings on pipe and fittings comply with Section 13 of this standard.

12. Certification

12.1 Upon request the purchaser shall be furnished certification, by the manufacturer, stating samples representing each lot have been tested and inspected as indicated in this specification and the requirements have been met. If required by the purchaser, certification shall be accompanied by test reports as prepared in accordance with Sections 10 and 11 of this standard. Tension test reports shall include breaking load machined diameters of test bars, and calculated tensile strength. Certification shall include legal name and address of the manufacturer.

13. Product Marking

13.1 Each length of pipe and each fitting shall be plainly marked with the country of origin and the manufacturer's name or manufacturer's registered trade-mark by which the manufacturer can be readily identified after installation. The marking shall be adequate identification of the manufacturer of the pipe and fittings if it readily identifies the manufacturer to the end user of the product.

13.1.1 *Pipe Markings*—The pipe shall be marked continuously on the barrel with a minimum of 0.75 in. (19 mm) starting within 3 in. of either end of the pipe.

13.1.2 On fittings, the marking shall not be located within the "W" dimension, as shown in Fig. 2. Cast markings shall be raised from the wall of the fitting unless otherwise noted.

14. Packaging and Package Marking

14.1 *Government Procurement*—Unless otherwise specified in the contract, the material shall be packaged in accordance with the supplier's standard practice, which will be acceptable to the carrier at lowest rates. Containers and packing shall comply with Uniform Freight Classification Rules or National Motor Freight Classification Rules. Marking for shipment of such material shall be in accordance with Fed. Std. No. 123 for civil agencies and MIL-STD-129 for military agencies.

15. Keywords

15.1 cast iron; hubless pipe and fittings; no-hub pipe and fittings; soil pipe

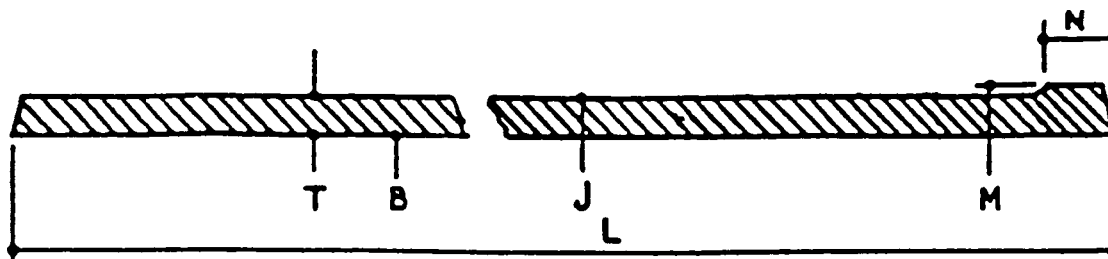

*Pipe shall be with or without a spigot bead.

Size	Barrel		Spigot		Barrel Thickness, T		Gasket Positioning Lug ^A W	Laying Length, L ^B 10 ft ± 0.50 in. (3.0480 m ± 13 mm)
	Inside Diameter B	Outside Diameter J	Outside Diameter M	Bead Width ^A N, ± 0.13 (3.3)	Nominal	Minimum		
1½	1.50 ± 0.09	1.90 ± 0.06	1.96 ± 0.06	0.25	0.16	0.13	1.13	120
2	(38.1 ± 2.29)	(48.26 ± 1.52)	(49.78 ± 1.52)	(6.35)	0.16	(3.3)	(28.7)	(3048)
	1.96 ± 0.09	2.35 ± 0.09	2.41 ± 0.09	0.25		0.13	1.13	120
3	(49.8 ± 2.29)	(59.69 ± 2.29)	(61.21 ± 2.29)	(6.35)	0.16	(3.3)	(28.7)	(3048)
	2.96 ± 0.09	3.35 ± 0.09	3.41 ± 0.09	0.25		0.13	1.13	120
4	(75.2 ± 2.29)	(85.09 ± 2.29)	(86.61 ± 2.29)	(6.35)	0.19	(3.3)	(28.7)	(3048)
	3.94 ± 0.09	4.38 ± 0.09	4.44 ± 0.09	0.31		0.15	1.13	120
5	(100.08 ± 2.29)	(111.25 ± 2.29)	(112.78 ± 2.29)	(7.87)	0.19	(3.81)	(28.7)	(3048)
	4.94 ± 0.09	5.30 ± 0.09	5.36 ± 0.09	0.31		0.15	1.50	120
6	(125.48 ± 2.29)	(134.62 ± 2.29)	(136.14 ± 2.29)	(7.87)	0.19	(3.81)	(38.1)	(3048)
	5.94 ± 0.09	6.30 ± 0.09	6.36 ± 0.09	0.31		0.15	1.50	120
8	(150.88 ± 2.29)	(160.02 ± 2.29)	(161.54 ± 2.29)	(7.87)	0.23	(3.81)	(38.1)	(3048)
	7.94 ± 0.13	8.38 ± 0.13	8.44 ± 0.09	0.31		0.17	2.00	120
10	(201.68 ± 3.3)	(212.85 ± 3.3)	(214.38 ± 2.29)	(7.87)	0.28	(4.32)	(50.8)	(3048)
	10.00 ± 0.13	10.56 ± 0.09	10.62 ± 0.09	0.31		0.22	2.00	120
12	(254 ± 3.3)	(268.22 ± 2.29)	(269.75 ± 2.29)	(7.87)	0.28	(5.59)	(50.8)	(3048)
	11.94 ± 0.9	12.50 ± .09	12.62 ± .09	0.31		.22	2.75	120
15	(303.28 ± 2.29)	(317.5 ± 2.29)	(320.55 ± 2.29)	(7.87)	0.36	(5.59)	(69.85)	(3048)
	15.11 ± .09	15.83 ± .09	16.12 ± .09	0.31		.30	2.75	120
	(383.79 ± 2.29)	(402.08 ± 2.29)	(409.45 ± 2.29)	(7.87)		(7.62)	(69.85)	(3048)

^A See Fig. 2 for details of the spigot and gasket positioning lug.

^B Laying lengths as listed in Fig. 1 shall be for pipe only, and such pipe shall be 10 ft (3m) long. Laying length for fittings are listed in the applicable tables.

FIG. 1 Dimensions and Tolerances in Inches (Millimetres) of Spigots and Barrels for Hubless Pipe and Fittings

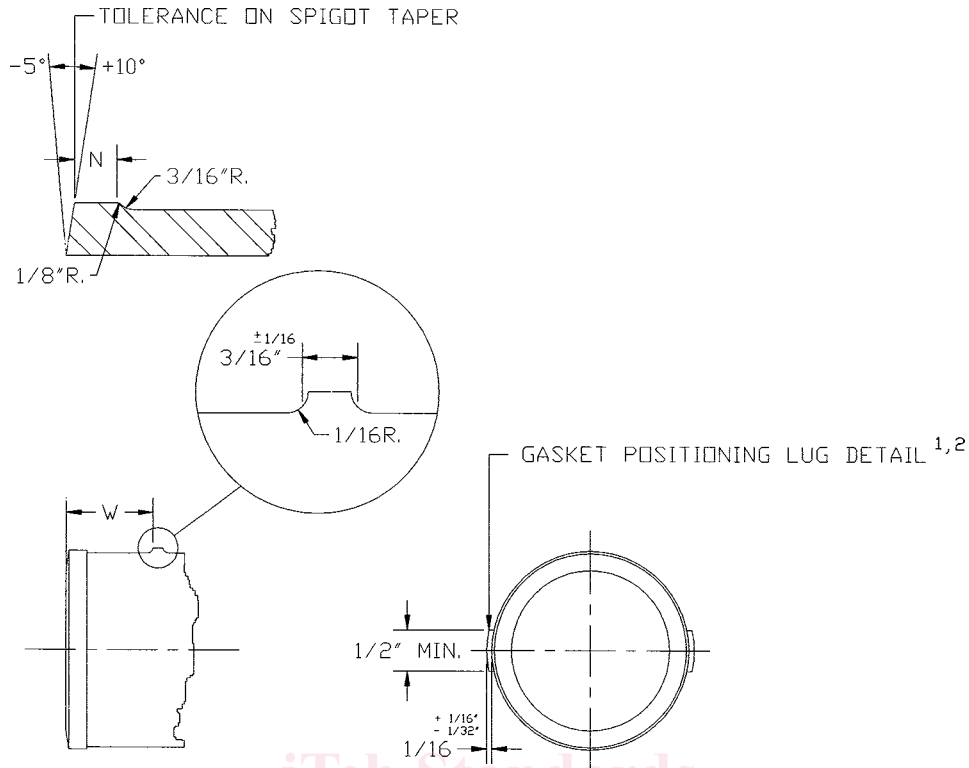

NOTE 1—Pipe shall be cast with or without the gasket positioning lugs. These lugs, as illustrated above, shall be cast as illustrated or be continuous around the entire circumference.

NOTE 2—Gasket positioning lugs shall be cast on all fittings except as otherwise noted. These lugs, as illustrated above, shall be cast as illustrated or be continuous around the entire circumference.

Size, in.	Spigot Detail, N in. (mm) ±0.13 (3.3)	Gasket Lug Location, W in. (mm) ±0.13 (3.3)
1½	0.25 (6)	1.13 (29)
2	0.25 (6)	1.13 (29)
3	0.25 (6)	1.13 (29)
4	0.25 (6)	1.13 (29)
5	0.31 (8)	1.50 (38)
6	0.31 (8)	1.50 (38)
8	0.31 (8)	2.00 (51)
10	0.31 (8)	2.00 (51)
12	0.31 (8)	2.75 (70)
15	0.31 (8)	2.75 (70)

FIG. 2 Details of Spigot Bead and Gasket Positioning Lug

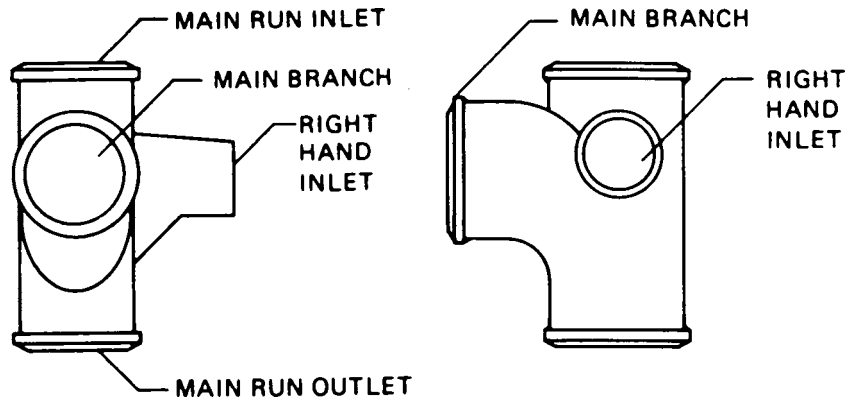
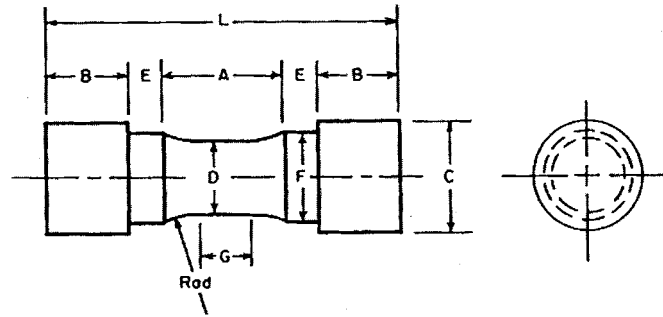

FIG. 3 Specifying Hand of Fittings with Side Inlets or Outlets

ASTM A 888 – 03



Dimensions, in (mm)	Tension Test Specimen B
G — Length of parallel, min	0.75 (19)
D — Diameter	0.750 + 0.015 (19.0 + 0.38)
R — Radius of fillet, min	1 (25)
A — Length of reduced section, min	1½ (38)
L — Overall length, min	4 (100)
C — Diameter of end section, approx	1¼ (32)
E — Length of shoulder, min	¼ (6)
F — Diameter of shoulder	5/16 + 1/64 (25 + 0.4)
B — Length of end section	^A

^A Optional to fit holders on testing machine. If threaded, root diameter shall not be less than dimension F.

FIG. 4 Sample Test Bar

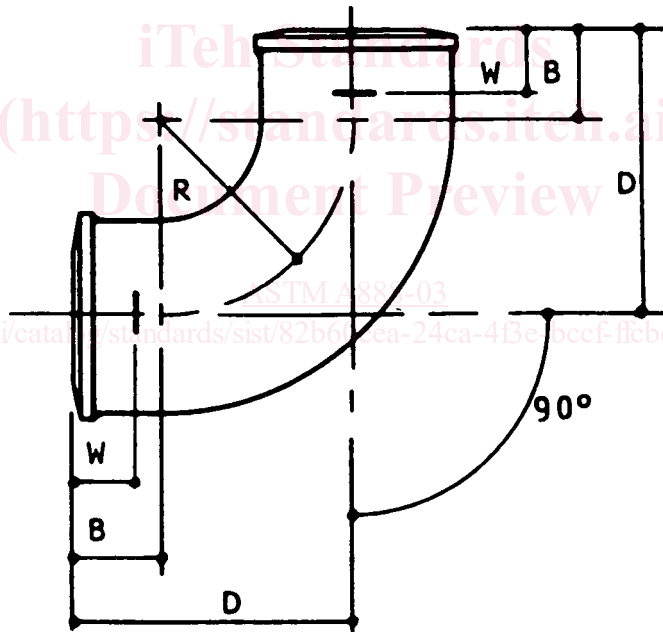

Item No.	ASA Code Group 022	Size, in.	Dimensions, in. (mm) ^A			
			B	D ^B ± 1/8 (3.2)	R	W
0188	7	1½	1½ (38)	4¼ (108)	2¾ (70)	1⅝ (29)
0190	3	2	1½ (38)	4½ (114)	3 (76)	1⅝ (29)
0192	9	3	1½ (38)	5 (127)	3½ (89)	1⅝ (29)
0194	5	4	1½ (38)	5½ (140)	4 (102)	1⅝ (29)
0196	0	5	2 (51)	6½ (165)	4½ (114)	1½ (38)
0198	6	6	2 (51)	7 (178)	5 (127)	1½ (38)
0200	0	8	2½ (64)	8½ (216)	6 (152)	2 (51)

^A For details of barrel, spigot, and gasket positioning lug, see Fig. 1 and Fig. 2.

^B Dimension D is laying length.

FIG. 5 ¼ Bend (corresponds to Table 5 of CISPI Specification 301)

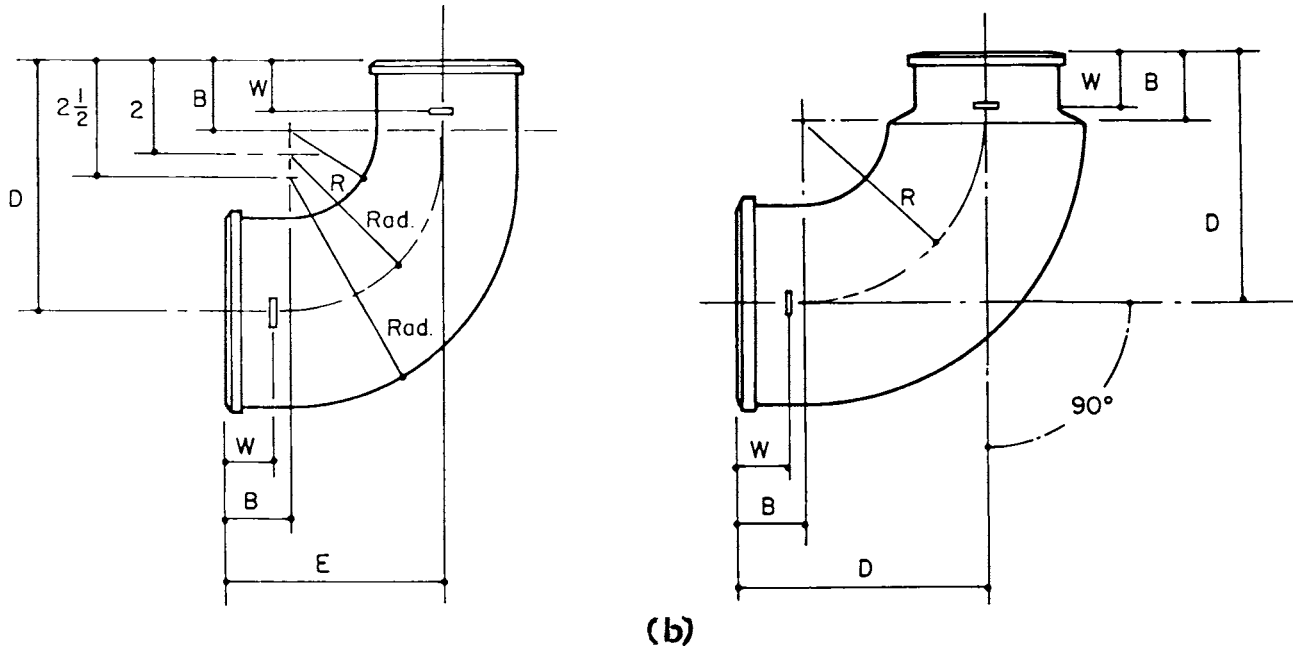

ASA Code Group 022		Sizes, in.		Dimensions, in. (mm) ^A				
Item No.	√	B	R	D ^B ± 1/8 (3.2)	E ^B ± 1/8 (3.2)	W		
Fig. (a)	0218	2	4 by 3	1 1/2 (38)	3 1/2 (89)	5 1/2 (140)	5 (127)	1 1/8 (29)
Fig. (b)	0218	2	4 by 3	1 1/2 (38)	4 (102)	5 1/2 (140)	...	1 1/8 (29)

^A For details of barrel, spigot, and gasket positioning lug, see Fig. 1 and Fig. 2.
^B Dimensions D and E are laying lengths.

FIG. 6 Reducing 1/4 Bend (corresponds to Tables 6 and 7 of CISPI Specification 301)

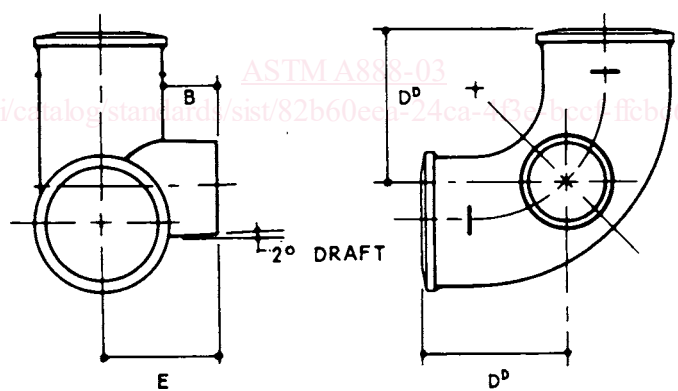

NOTE 1—For details of 1/4 bend, see Fig. 5.
 NOTE 2—Inclusion of spigot bead and positioning lug optional with manufacturer based on casting method used.

ASA Code Group 022		Sizes, in.		Dimensions, in. (mm) ^A		
Item No.	√	B	E ^B ± 1/8 (3.2)	D ^B		
0236	4	3 by 2	1 1/2 (38)	3 1/4 (83)	4 (102)	
0238	0	4 by 2	1 1/2 (38)	3 3/4 (95)	4 5/16 (110)	

^A For details of barrel, spigot, and gasket positioning lug, see Fig. 1 and Fig. 2.
^B Dimension E is laying length.

FIG. 7 1/4 Bend With Side Opening (corresponds to Table 8 of CISPI Specification 301)

ASTM A 888 – 03

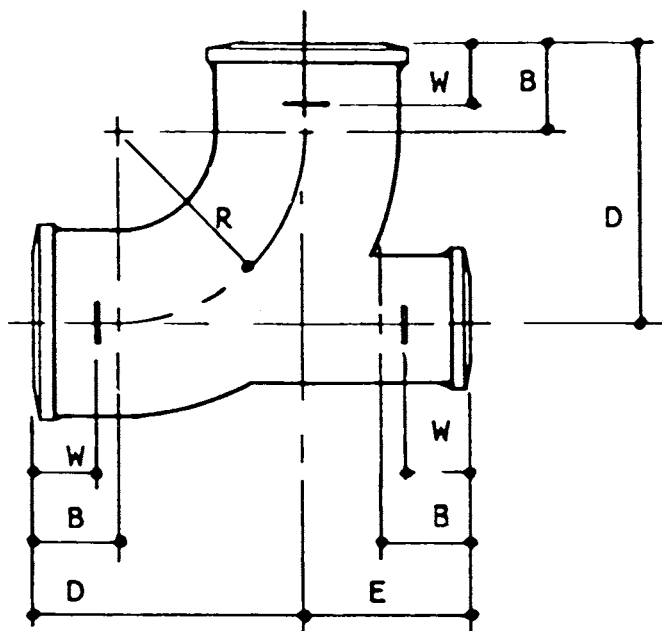

ASA Code Group 022		Size, in.	Dimensions, in. (mm) ^A				
Item No.	√		B	D ^B ± 1/8 (3.2)	E ^B ± 1/8 (3.2)	R	W
0280	2	3 by 2	1 1/2 (38)	5 (127)	2 7/8 (73)	3 1/2 (89)	1 1/8 (29)
0282	8	4 by 2	1 1/2 (38)	5 1/2 (140)	3 1/4 (83)	4 (102)	1 1/8 (29)

^A For details of barrel, spigot, and gasket positioning lug, see Fig. 1 and Fig. 2.

^B Dimensions D and E are laying lengths.

FIG. 8 1/4 Bend With Heel Opening (corresponds to Table 9 of CISPI Specification 301)

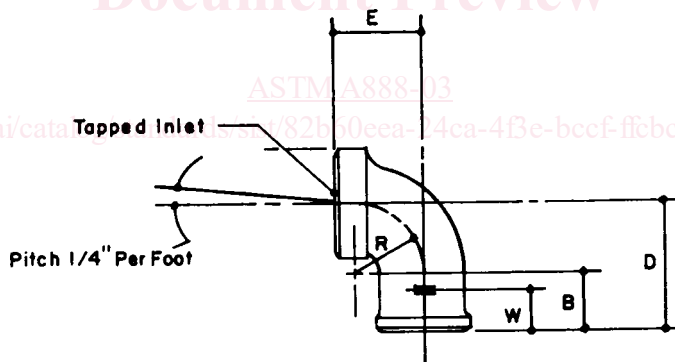

ASA Code Group 022		Size, in.	Dimensions, in. (mm) ^A					
Item No.	√		B	E	D ^B ± 1/8 (3.2)	R	IPS Tapping ^C	W
0324	8	1 1/2 by 1 1/4	1 1/2 (38)	2 (51)	3 (76)	1 3/4 (44)	1 1/4 (32)	1 1/8 (29)
0326	3	1 1/2 by 1 1/2	1 1/2 (38)	2 (51)	3 (76)	1 3/4 (44)	1 1/2 (38)	1 1/8 (29)
0328	9	2 by 1 1/4	1 1/2 (38)	2 1/4 (57)	3 1/4 (83)	1 3/4 (44)	1 1/4 (32)	1 1/8 (29)
0330	5	2 by 1 1/2	1 1/2 (38)	2 1/4 (57)	3 1/4 (83)	1 3/4 (44)	1 1/2 (38)	1 1/8 (29)

^A For details of barrel, spigot, and gasket positioning lug, see Fig. 1 and Fig. 2.

^B Dimension D is laying length.

^C For details of tapping bosses, see Fig. 63.

FIG. 9 Tapped 1/4 Bend (corresponds to Table 11 of CISPI Specification 301)

ASTM A 888 – 03

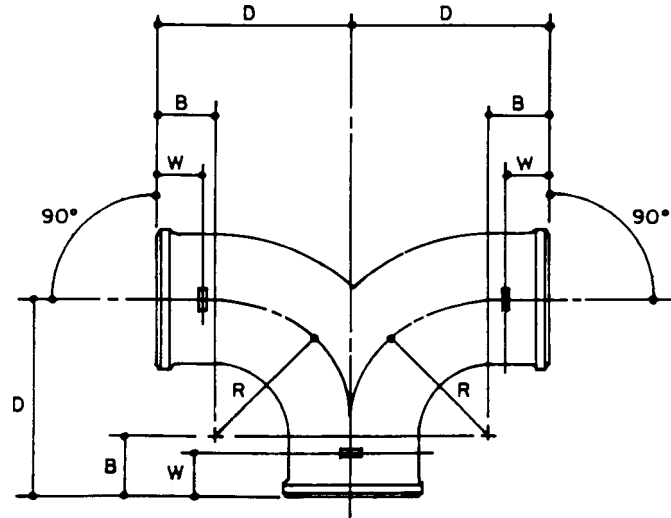

ASA Code Group 022		Dimensions, in. (mm) ^A				
Item No.	√	Size, in.	D ^B ± 1/8 (3.2)	R	B	W
0402	2	2	4 1/2 (114)	3 (76)	1 1/2 (38)	1 1/8 (29)
0404	8	3	5 (127)	3 1/2 (89)	1 1/2 (38)	1 1/8 (29)
0406	3	4	5 1/2 (140)	4 (102)	1 1/2 (38)	1 1/8 (29)

^A For details of barrel, spigot, and gasket positioning lug, see Fig. 1 and Fig. 2.
^B Dimension D is laying length.

FIG. 10 Double 1/4 Bend (corresponds to Table 13 of CISPI Specification 301)

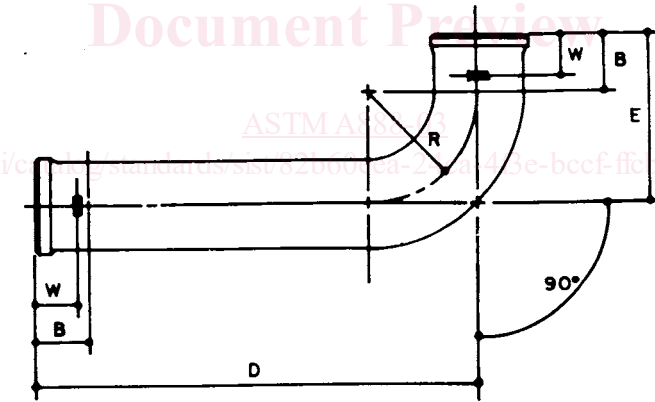

ASA Code Group 022		Size, in.	Dimensions, in. (mm) ^A				
Item No.	√		B	E ^B ± 1/8 (3.2)	D ^B ± 1/8 (3.2)	R	W
0424	6	2 by 12	1 1/2 (38)	4 1/2 (114)	12 (305)	3 (76)	1 1/8 (29)
0423	8	2 by 16	1 1/2 (38)	4 1/2 (114)	16 (406)	3 (76)	1 1/8 (29)
0425	3	2 by 18	1 1/2 (38)	4 1/2 (114)	18 (457)	3 (76)	1 1/8 (29)
0426	1	3 by 12	1 1/2 (38)	5 (127)	12 (305)	3 1/2 (89)	1 1/8 (29)
0427	9	3 by 18	1 1/2 (38)	5 (127)	18 (457)	3 1/2 (89)	1 1/8 (29)
0428	7	4 by 12	1 1/2 (38)	5 1/2 (140)	12 (305)	4 (102)	1 1/8 (29)
0431	1	4 by 18	1 1/2 (38)	5 1/2 (140)	18 (457)	4 (102)	1 1/8 (29)

^A For details of barrel, spigot, and gasket positioning lug, see Fig. 1 and Fig. 2.
^B Dimensions D and E are laying lengths.

FIG. 11 Long 1/4 Bend (corresponds to Table 14 of CISPI Specification 301)

ASTM A 888 – 03

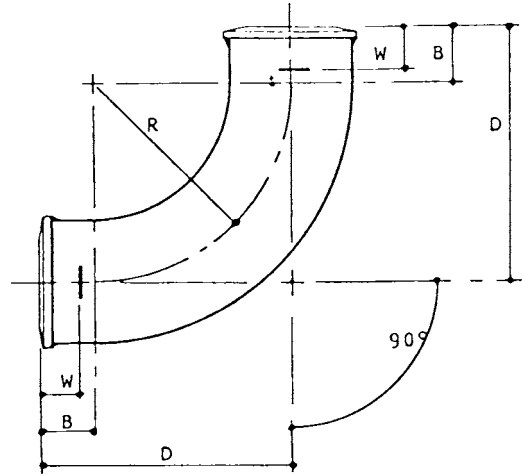

ASA Code Group 022		Size, in.	Dimensions, in. (mm) ^A			
Item No.	✓		B	D ^B ± 1/8 (3.2)	R	W
0462	6	2	1 1/2 (38)	6 1/2 (165)	5 (127)	1 1/8 (29)
0464	2	3	1 1/2 (38)	7 (178)	5 1/2 (140)	1 1/8 (29)
0468	3	4	1 1/2 (38)	7 1/2 (191)	6 (152)	1 1/8 (29)
0470	9	5	2 (51)	8 1/2 (216)	6 1/2 (165)	1 1/2 (38)
0472	5	6	2 (51)	9 (229)	7 (178)	1 1/2 (38)
0474	1	8	2 1/2 (64)	10 1/2 (267)	8 (203)	2 (51)
0475	8	10	3 (76)	12 (305)	9 (229)	2 (51)
0476	8	12	3 1/4 (83)	13 1/4 (337)	10 (254)	2 3/4 (70)
0477	8	15	3 1/4 (83)	14 3/4 (375)	11 1/2 (292)	2 3/4 (70)

^A For details of barrel, spigot, and gasket positioning lug, see Fig. 1 and Fig. 2.

^B Dimension D is laying length.

FIG. 12 Short Sweep (corresponds to Table 15 of CISPI Specification 301)

ASTMA888-03

<https://standards.iteh.ai/catalog/standards/sist/82b60eea-24ca-43e-bccf-ffc6c66c1f30/astm-a888-03>

ASTM A 888 - 03

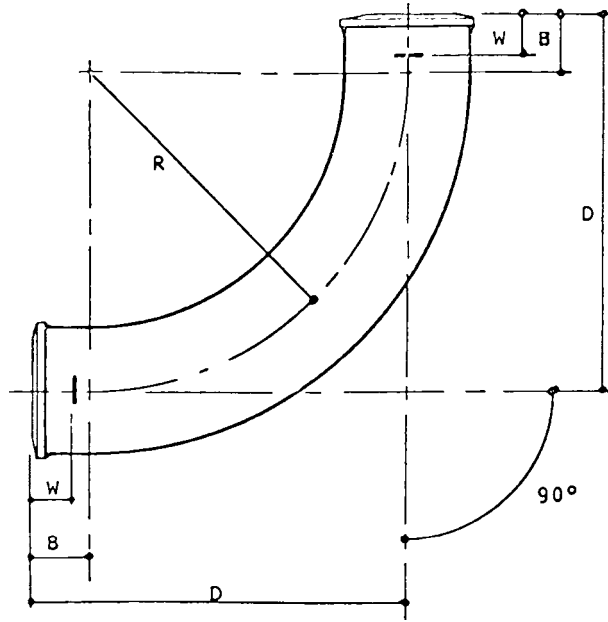

Item No.	√	ASA Code Group 022	Size, in.	Dimensions, in. (mm) ^A		
				B	D ^B ±1/8 (3.2)	R
0492	3	1 1/2	1 1/2 (38)	9 1/4 (235)	7 3/4 (197)	1 1/8 (29)
0494	9	2	1 1/2 (38)	9 1/2 (241)	8 (203)	1 1/8 (29)
0496	4	3	1 1/2 (38)	10 (254)	8 1/2 (216)	1 1/8 (29)
0498	0	4	1 1/2 (38)	10 1/2 (267)	9 (229)	1 1/8 (29)
0500	3	5	2 (51)	11 1/2 (292)	9 1/2 (241)	1 1/2 (38)
0502	9	6	2 (51)	12 (305)	10 (254)	1 1/2 (38)

^A For details of barrel, spigot, and gasket positioning lug, see Fig. 1 and Fig. 2.

^B Dimension D is laying length.

FIG. 13 Long Sweep (corresponds to Table 17 of CISPI Specification 301)

<https://standards.iteh.ai/catalog/standards/sist/415c-0ccc-1c6c66c1f30/astm-a888-03>

ASTM A 888 - 03

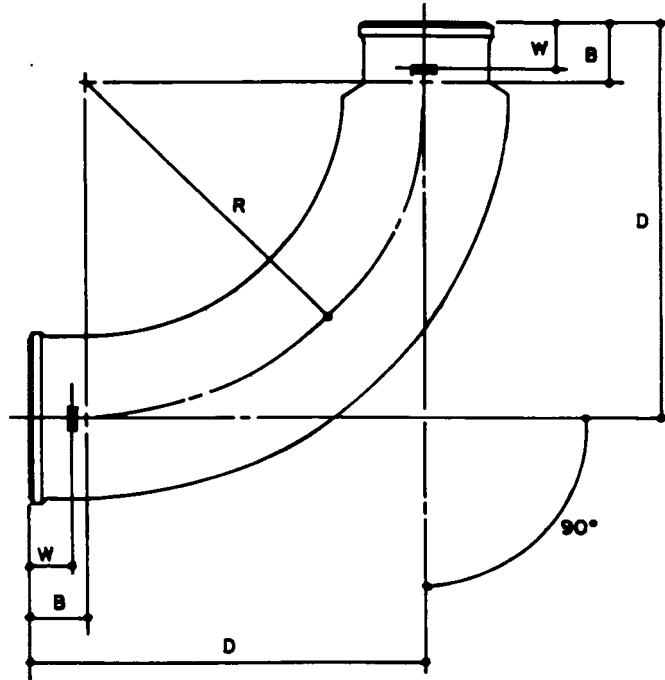

ASA Code		Dimensions, in. (mm) ^A				
Group 022		Size, in.	B	D ^B ± 1/8 (3.2)	R	W
Item No.	✓					
0516	9	3 by 2	1½ (38)	10 (254)	8½ (216)	1½ (29)
0518	5	4 by 3	1½ (38)	10½ (267)	9 (229)	1½ (29)

^A For details of barrel, spigot, and gasket positioning lug, see Fig. 1 and Fig. 2.
^B Dimension D is laying length.

FIG. 14 Reducing Long Sweep (corresponds to Table 18 of CISPI Specification 301)

ASTMA888-03

<https://standards.iteh.ai/catalog/standards/sist/82360eaa-24ca-4f3e-bccf-fc6c66c1f30/astm-a888-03>

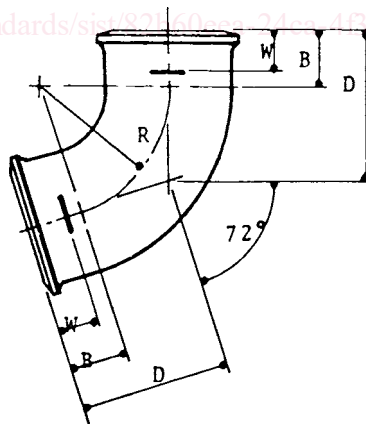

ASA Code		Dimensions, in. (mm) ^A				
Group 022		Size, in.	B	D ^B ± 1/8 (3.2)	R	W
Item No.	✓					
0536	7	2	1½ (38)	3 11/16 (94)	3 (76)	1½ (29)
0538	3	3	1½ (38)	4 1/16 (103)	3 1/2 (89)	1½ (29)
0540	9	4	1½ (38)	4 7/16 (113)	4 (102)	1½ (29)

^A For details of barrel, spigot, and gasket positioning lug, see Fig. 1 and Fig. 2.
^B Dimension D is laying length.

FIG. 15 1/8 Bend (corresponds to Table 19 of CISPI Specification 301)

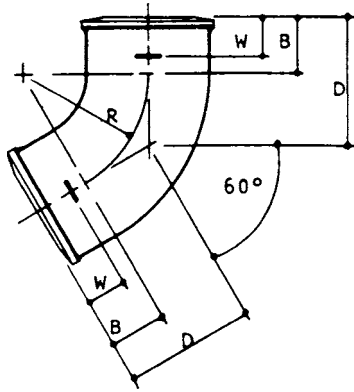

ASA Code Group 022		Dimensions, in. (mm) ^A				
Size, in.		B	D ^B ± 1/8 (3.2)	R	W	
Item No.	✓					
0570	6	2 1/2 (38)	3 1/4 (83)	3 (76)	1 1/8 (29)	
0572	2	3 1/2 (38)	3 1/2 (89)	3 1/2 (89)	1 1/8 (29)	
0574	8	4 1/2 (38)	3 3/16 (97)	4 (102)	1 1/8 (29)	

^A For details of barrel, spigot, and gasket positioning lug, see Fig. 1 and Fig. 2.

^B Dimension D is laying length.

FIG. 16 1/8 Bend (corresponds to Table 20 of CISPI Specification 301)

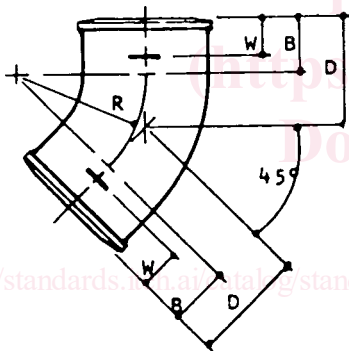

ASA Code Group 022		Dimensions, in. (mm) ^A				
Size, in.		B	D ^B ± 1/8 (3.2)	R	W	
Item No.	✓					
0604	3	1 1/2 (38)	2 5/8 (67)	2 3/4 (70)	1 1/8 (29)	
0606	8	2 1/2 (38)	2 3/4 (70)	3 (76)	1 1/8 (29)	
0608	4	3 1/2 (38)	3 (76)	3 1/2 (89)	1 1/8 (29)	
0610	0	4 1/2 (38)	3 1/8 (79)	4 (102)	1 1/8 (29)	
0612	6	5 2 (51)	3 7/8 (98)	4 1/2 (114)	1 1/2 (38)	
0614	2	6 2 (51)	4 1/16 (103)	5 (127)	1 1/2 (38)	
0616	7	8 2 1/2 (64)	5 (127)	6 (152)	2 (51)	
0617	5	10 3 (76)	5 15/16 (151)	7 (178)	2 (51)	
0618	5	12 3 1/4 (83)	6 9/16 (167)	8 (203)	2 3/4 (70)	
0619	5	15 3 1/4 (83)	7 3/16 (183)	9 1/2 (241)	2 3/4 (70)	

^A For details of barrel, spigot, and gasket positioning lug, see Fig. 1 and Fig. 2.

^B Dimension D is laying length.

FIG. 17 1/8 Bend (corresponds to Table 21 of CISPI Specification 301)