Infusion equipment for medical use —

Part 3:

Aluminium caps for infusion bottles

Matériel de perfusion à usage médical

Partie 3: Capsules en aluminium pour flacons de perfusion

iTeh STANDARD PREVIEW
(standards.iteh.ai)

ISO 8536-3:1999

<https://standards.iteh.ai/catalog/standards/sist/87c033ce-ab1f-43d2-beda-46bc803195fe/iso-8536-3-1999>



Foreword

ISO (the International Organization for Standardization) is a worldwide federation of national standards bodies (ISO member bodies). The work of preparing International Standards is normally carried out through ISO technical committees. Each member body interested in a subject for which a technical committee has been established has the right to be represented on that committee. International organizations, governmental and non-governmental, in liaison with ISO, also take part in the work. ISO collaborates closely with the International Electrotechnical Commission (IEC) on all matters of electrotechnical standardization.

International Standards are drafted in accordance with the rules given in the ISO/IEC Directives, Part 3.

Draft International Standards adopted by the technical committees are circulated to the member bodies for voting. Publication as an International Standard requires approval by at least 75 % of the member bodies casting a vote.

Attention is drawn to the possibility that some of the elements of this part of ISO 8536 may be the subject of patent rights. ISO shall not be held responsible for identifying any or all such patent rights.

International Standard ISO 8536-3 was prepared by Technical Committee ISO/TC 76, *Transfusion, infusion and injection equipment for medical and pharmaceutical use*.

This second edition cancels and replaces the first edition (ISO 8536-3:1992), which has been technically revised.

ISO 8536 consists of the following parts, under the general title *Infusion equipment for medical use*:

- Part 1: *Infusion glass bottles*
- Part 2: *Closures for infusion bottles*
- Part 3: *Aluminium caps for infusion bottles*
- Part 4: *Infusion sets for single use, gravity feed*
- Part 5: *Burette-type infusion sets*
- Part 6: *Freeze-drying closures for infusion bottles*
- Part 7: *Caps made of aluminium-plastics combinations for infusion bottles*

© ISO 1999

All rights reserved. Unless otherwise specified, no part of this publication may be reproduced or utilized in any form or by any means, electronic or mechanical, including photocopying and microfilm, without permission in writing from the publisher.

International Organization for Standardization
Case postale 56 • CH-1211 Genève 20 • Switzerland
Internet iso@iso.ch

Printed in Switzerland

Introduction

The materials from which infusion glass bottles (including elastomeric closures) are made are suitable primary packaging materials for storing infusion solutions until they are administered. However, in this part of ISO 8536, aluminium caps are not considered as primary packaging material in direct contact with the infusion solution.

iTeh STANDARD PREVIEW (standards.iteh.ai)

[ISO 8536-3:1999](https://standards.iteh.ai/catalog/standards/sist/87c033ce-ab1f-43d2-beda-46bc803195fe/iso-8536-3-1999)

<https://standards.iteh.ai/catalog/standards/sist/87c033ce-ab1f-43d2-beda-46bc803195fe/iso-8536-3-1999>

iTeh STANDARD PREVIEW
(standards.iteh.ai)

ISO 8536-3:1999

<https://standards.iteh.ai/catalog/standards/sist/87c033ce-ab1f-43d2-beda-46bc803195fe/iso-8536-3-1999>

Infusion equipment for medical use —

Part 3: Aluminium caps for infusion bottles

1 Scope

This part of ISO 8536 specifies aluminium caps for infusion glass bottles which are in accordance with ISO 8536-1.

2 Normative references

The following normative documents contain provisions which, through reference in this text, constitute provisions of this part of ISO 8536. For dated references, subsequent amendments to, or revisions of, any of these publications do not apply. However, parties to agreements based on this part of ISO 8536 are encouraged to investigate the possibility of applying the most recent editions of the normative documents indicated below. For undated references, the latest edition of the normative document referred to applies. Members of ISO and IEC maintain registers of currently valid International Standards.

ISO 2768-1:—¹⁾, *Geometrical product specifications (GPS) — General tolerances — Part 1: Tolerances for linear and angular dimensions without individual tolerance indications*.

ISO 2768-2:1989, *General tolerances — Part 2: Geometrical tolerances for features without individual tolerance indications*.

ISO 8536-1:1991, *Infusion equipment for medical use — Part 1: Infusion glass bottles*.

ISO 8872:1988, *Aluminium caps for transfusion, infusion and injection bottles — General requirements and test methods*.

3 Dimensions and tolerances

3.1 Dimensions

The dimensions of the caps shall be as shown in Figures 1 to 3, and as given in Table 1.

The shapes of the caps are shown only as typical examples.

The components of a two-piece tear-off cap are:

- an aluminium cap with centre hole, type A;
- a protective aluminium cap with complete tear-off tab, type F;

1) To be published. (Revision of ISO 2768-1:1989)

The components of a three-piece tear-off cap are:

- an aluminium cap with centre hole, type A;
- a protective disc E;
- a protective aluminium cap with complete tear-off tab, type F.

NOTE The width and the number of bridges for types C and F are a function of the intended resistance.

3.2 Tolerances

The tolerances shall be in accordance with ISO 2768-1 and ISO 2768-2.

4 Designation

Caps shall be designated as one-, two- or three-piece, and according to type.

The designation is expressed as the word "cap", the number and part of this International Standard, followed by the type letter plus the number of pieces if more than one, and the nominal size of the cap.

EXAMPLE A type A two-piece aluminium cap of nominal size 32 complying with the requirements of this part of ISO 8536 is designated:

iTeh STANDARD PREVIEW
Cap ISO 8536-3 - A2 - 32
(standards.iteh.ai)

5 Requirements

5.1 General requirements

<https://standards.iteh.ai/catalog/standards/sist/87c033ce-ab1f-43d2-beda-46bc803195fe/iso-8536-3-1999>

5.1.1 Under normal conditions of use and handling, assembled caps shall be considered as a whole until the crimping operation.

5.1.2 The caps shall meet the requirements of ISO 8872.

5.2 Force required to remove tab

5.2.1 Three-bridge tab (type C)

The force needed to remove the tab shall be determined as specified in ISO 8872 and shall be within the range given in Table 2.

5.2.2 Complete tear-off tab (type F)

The force needed to remove the tab completely shall be determined as specified in ISO 8872 and shall be within the range given in Table 2.

5.2.3 Three-piece tear-off cap

The minimum force required to push the cap with centre hole (type A) into the protective cap with complete tear-off tab (type F) shall be 5 N.

6 Packaging

The packaging of aluminium caps shall comply with the requirements of ISO 8872.

7 Marking

The aluminium caps shall be marked in accordance with ISO 8872 and with the designation as defined in clause 4.

Table 1 — Dimension of aluminium caps

Dimensions in millimetres

Nominal size	Type	d_1 +0,1 -0,05	d_2 ± 0,2	d_4 min.	h ± 0,3	e^a	r ± 0,2	
28	A, C	28,1	12 to 21		8,6	0,168 ≤ e ≤ 0,242	1	
	Disc E			27,3				
	F		15 to 21				1	
32	A, C	32,6	15 to 21		11,9			1
	Disc E			30				
	F		15 to 21				1	

^a The thickness shall be agreed between the manufacturer and the user within the given range. The thickness shall not differ from the nominal value by more than 0,022 mm. The extreme limits are given without tolerance.

ISO 8536-3:1999

<https://standards.iteh.ai/catalog/standards/sist/87c033ce-ab1f-43d2-beda-46bc803195fe/iso-8536-3-1999>

Dimensions in millimetres

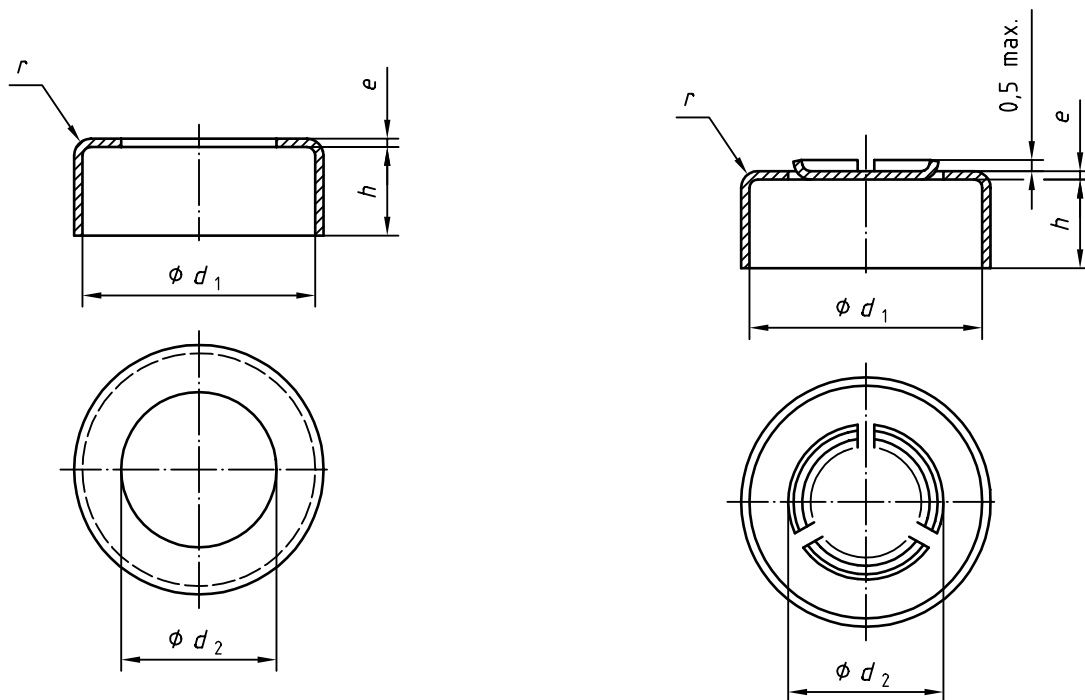

a) Type A — Aluminium cap with centre hole

b) Type C — Aluminium cap with three-bridge tab

Figure 1 — One-piece tear-off cap

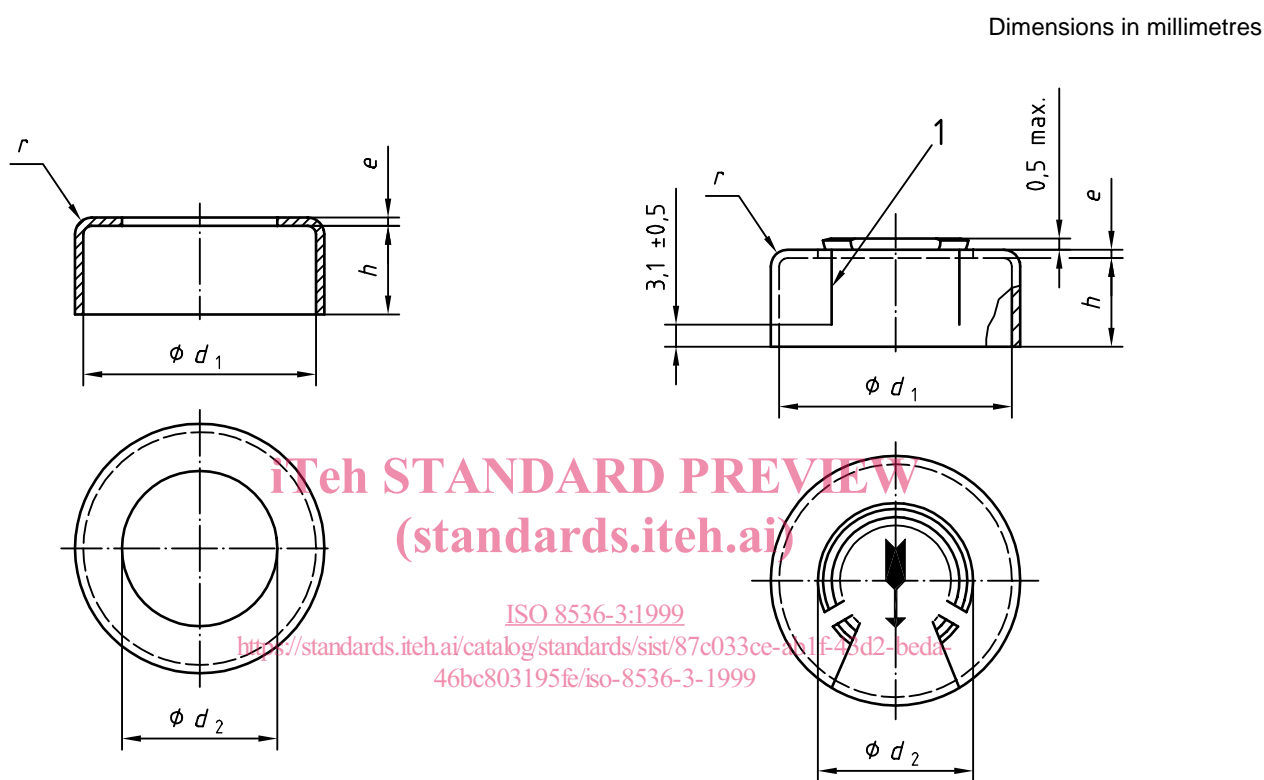

a) Type A — Aluminium cap with centre hole

b) Type F — Protective aluminium cap with complete tear-off tab

Key

- 1 Tear-off perforation

Figure 2 — Two-piece tear-off cap

Dimensions in millimetres

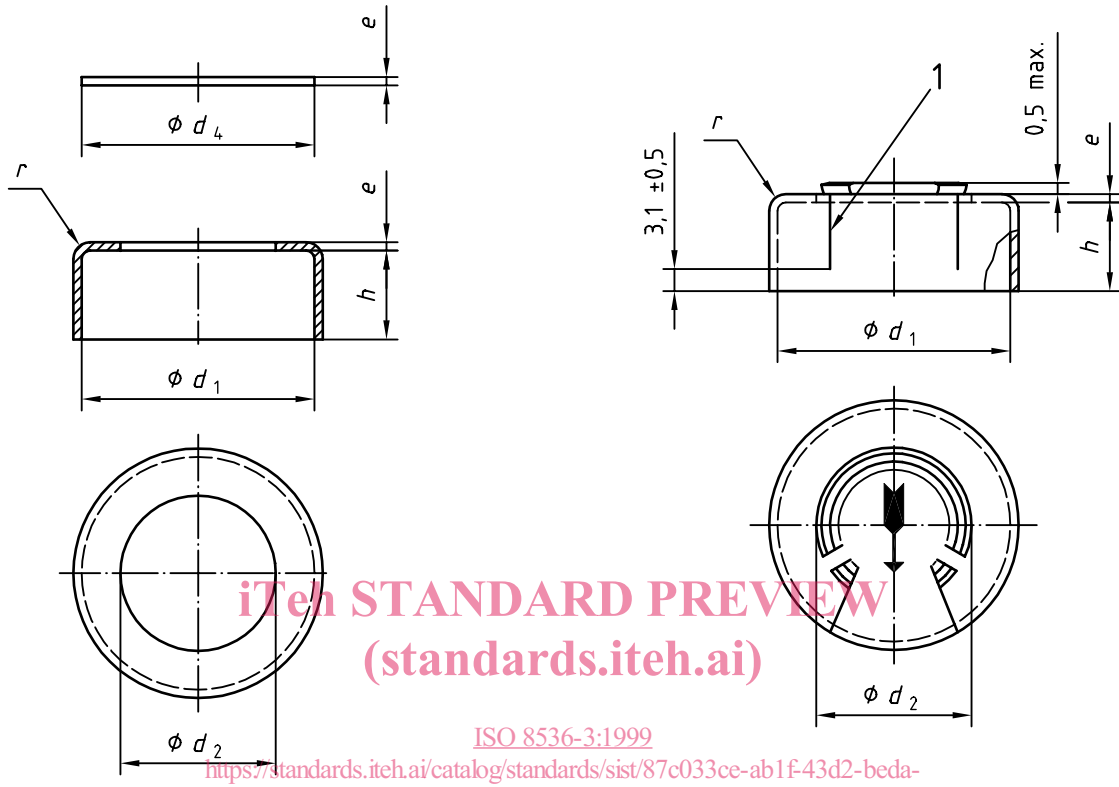

iTeh STANDARD PREVIEW
(standards.iteh.ai)

ISO 8536-3:1999

<https://standards.iteh.ai/catalog/standards/sist/87c033ce-ab1f-43d2-beda-46bc803195fe/iso-8536-3-1999>

a) Type A — Aluminium cap with centre hole b) Type F — Protective aluminium cap with complete tear-off tab

Key

1 Tear-off perforation

Figure 3 — Three-piece tear-off cap

Table 2 — Minimum and maximum forces to remove the complete tear-off tab (type F) or three-bridge tab (type C)

Force in newtons

Nominal size	Force to break bridges		Force to tear off tab completely	
	min.	max.	min.	max.
28	10	40	5	25
32	30	60	20	40

NOTE In the case of multiple bridges, the resistance against pressure shall be sufficient but the breaking force is reduced accordingly.