

---

---

**Aerospace — MJ threads —**

**Part 3:**

**Limit dimensions for fittings for fluid systems**

*Aéronautique et espace — Filetage MJ —*

*Partie 3: Dimensions limites pour raccordements de systèmes de fluides*

iTeh STANDARD PREVIEW  
(standards.iteh.ai)

[ISO 5855-3:1999](https://standards.iteh.ai/catalog/standards/sist/e350af8e-f45f-4bc9-8240-50d56864ba29/iso-5855-3-1999)

<https://standards.iteh.ai/catalog/standards/sist/e350af8e-f45f-4bc9-8240-50d56864ba29/iso-5855-3-1999>



## Foreword

ISO (the International Organization for Standardization) is a worldwide federation of national standards bodies (ISO member bodies). The work of preparing International Standards is normally carried out through ISO technical committees. Each member body interested in a subject for which a technical committee has been established has the right to be represented on that committee. International organizations, governmental and non-governmental, in liaison with ISO, also take part in the work. ISO collaborates closely with the International Electrotechnical Commission (IEC) on all matters of electrotechnical standardization.

International Standards are drafted in accordance with the rules given in the ISO/IEC Directives, Part 3.

Draft International Standards adopted by the technical committees are circulated to the member bodies for voting. Publication as an International Standard requires approval by at least 75 % of the member bodies casting a vote.

International Standard ISO 5855-3 was prepared by Technical Committee ISO/TC 20, *Aircraft and space vehicles*, Subcommittee SC 4, *Aerospace fastener systems*.

This second edition cancels and replaces the first edition (ISO 5855-3:1988), of which it constitutes a technical revision.

ISO 5855 consists of the following parts, under the general title *Aerospace — MJ threads*:

- *Part 1: General requirements*
- *Part 2: Limit dimensions for bolts and nuts*
- *Part 3: Limit dimensions for fittings for fluid systems*

**ITeH STANDARD PREVIEW**  
(standards.iteh.ai)  
<https://standards.iteh.ai/catalog/standards/sist/e350af8e-f45f-4bc9-8240-50d56864ba29/iso-5855-3-1999>

© ISO 1999

All rights reserved. Unless otherwise specified, no part of this publication may be reproduced or utilized in any form or by any means, electronic or mechanical, including photocopying and microfilm, without permission in writing from the publisher.

International Organization for Standardization  
Case postale 56 • CH-1211 Genève 20 • Switzerland  
Internet iso@iso.ch

Printed in Switzerland

# Aerospace — MJ threads —

## Part 3:

## Limit dimensions for fittings for fluid systems

### 1 Scope

This part of ISO 5855 specifies limit dimensions of MJ threads for fluid systems fittings for aerospace construction.

### 2 Normative references

The following normative documents contain provisions which, through reference in this text, constitute provisions of this part of ISO 5855. For dated references, subsequent amendments to, or revisions of, any of these publications do not apply. However, parties to agreements based on this part of ISO 5855 are encouraged to investigate the possibility of applying the most recent edition of the normative documents indicated below. For undated references, the latest edition of the normative document referred to applies. Members of ISO and IEC maintain registers of currently valid International Standards.

ISO 965-1:1998, *ISO general-purpose metric screw threads — Tolerances — Part 1: Principles and basic data.*

[ISO 5855-3:1999](#)

ISO 5855-1:1999, *Aerospace — MJ threads — Part 1: General requirements.*

<https://standards.iteh.ai/catalog/standards/si/50d56864ba29/iso-5855-3-1999>

### 3 Nominal diameters and pitches

See Table 1.

**Table 1 — Nominal diameters and pitches**

Dimensions in millimetres

Nominal diameter <i>d</i> or <i>D</i>	Pitch <i>P</i>	Nominal diameter <i>d</i> or <i>D</i>	Pitch <i>P</i>
8	1	27	1,5
10		30	
12	1,25	33	
14	1,5	36	
16		39	
18		42	2
20		48	
22	50		
24			

### 4 Tolerance classes

See Table 2.

**Table 2 — Tolerance classes**

Assembly	External threads		Internal threads	
	<i>d</i>		<i>D</i> <sub>1</sub>	
General case (clearance may be nil)	<i>d</i>	6h	<i>D</i> <sub>1</sub>	5H
	<i>d</i> <sub>2</sub>	4h	<i>D</i> <sub>2</sub>	4H
Requiring systematic clearance	<i>d</i>	6g	<i>D</i> <sub>1</sub>	5H
	<i>d</i> <sub>2</sub>	4g	<i>D</i> <sub>2</sub>	4H

### 5 Provisions for coated threads

Before coating, the dimensions of the threads shall be compatible with the thickness of the coating selected and with the limit dimensions for finished parts specified in clause 6.

### 6 Limit dimensions for finished parts (coated or uncoated)

#### 6.1 External threads

##### 6.1.1 4h6h external threads

iTeh STANDARD PREVIEW  
(standards.iteh.ai)

Figure 1 illustrates the position and the form of the limit profiles (maximum and minimum) in relation to the basic profile (see ISO 5855-1).

Tables 3 and 4 specify the limit dimensions.

ISO 5855-3:1999

https://standards.iteh.ai/catalog/standards/sist/e350af8e-f45f-4bc9-8240-50d56864ba29/iso-5855-3-1999

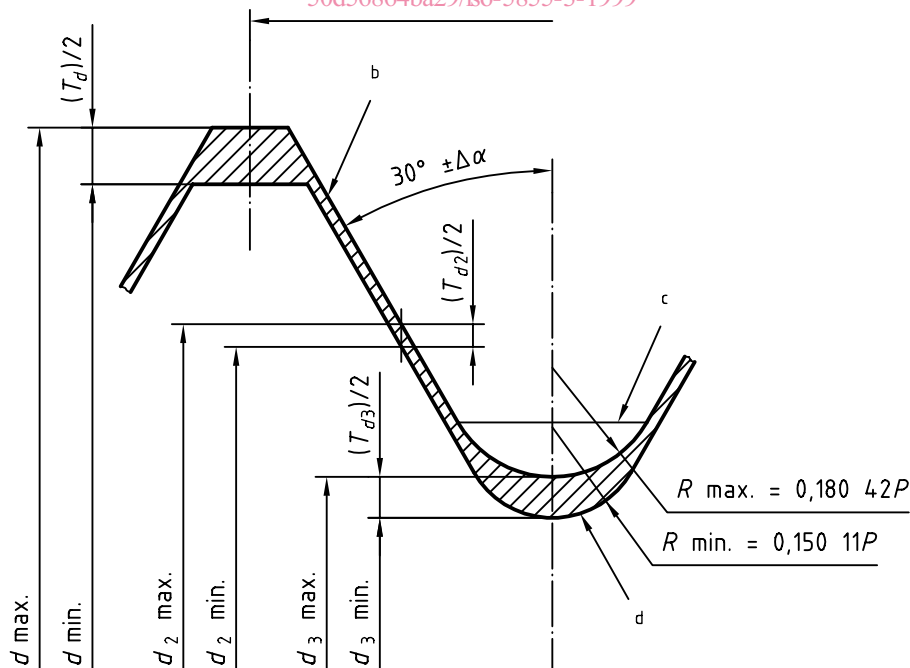

- a Pitch ± ΔP
- b Basic and maximum profiles
- c Basic profile
- d Minimum profile

**Figure 1 — Limit profiles for external threads (clearance may be nil)**

Table 3 — Limit dimensions for 4h6h external threads

Dimensions in millimetres

Thread designation	Major diameter $d$			Pitch diameter $d_2$			Minor diameter $d_3$		
	max.	min.	$T_d$ (6h) <sup>a</sup>	max.	min.	$T_{d2}$ (4h) <sup>a</sup>	max.	min.	$T_{d3}$
MJ8 × 1-4h6h	8,00	7,82	0,18	7,350	7,279	0,071	6,845	6,713	0,132
MJ10 × 1-4h6h	10,00	9,82	0,18	9,350	9,279	0,071	8,845	8,713	0,132
MJ12 × 1,25-4h6h	12,000	11,788	0,212	11,188	11,103	0,085	10,557	10,396	0,161
MJ14 × 1,5-4h6h	14,000	13,764	0,236	13,026	12,936	0,09	12,268	12,087	0,181
MJ16 × 1,5-4h6h	16,000	15,764	0,236	15,026	14,936	0,09	14,268	14,087	0,181
MJ18 × 1,5-4h6h	18,000	17,764	0,236	17,026	16,936	0,09	16,268	16,087	0,181
MJ20 × 1,5-4h6h	20,000	19,764	0,236	19,026	18,936	0,09	18,268	18,087	0,181
MJ22 × 1,5-4h6h	22,000	21,764	0,236	21,026	20,936	0,09	20,268	20,087	0,181
MJ24 × 1,5-4h6h	24,000	23,764	0,236	23,026	22,931	0,095	22,268	22,082	0,186
MJ27 × 1,5-4h6h	27,000	26,764	0,236	26,026	25,931	0,095	25,268	25,082	0,186
MJ30 × 1,5-4h6h	30,000	29,764	0,236	29,026	28,931	0,095	28,268	28,082	0,186
MJ33 × 1,5-4h6h	33,000	32,764	0,236	32,026	31,931	0,095	31,268	31,082	0,186
MJ36 × 1,5-4h6h	36,000	35,764	0,236	35,026	34,931	0,095	34,268	34,082	0,186
MJ39 × 1,5-4h6h	39,000	38,764	0,236	38,026	37,931	0,095	37,268	37,082	0,186
MJ42 × 2-4h6h	42,00	41,72	0,28	40,701	40,595	0,106	39,691	39,463	0,228
MJ48 × 2-4h6h	48,00	47,72	0,28	46,701	46,589	0,112	45,691	45,457	0,234
MJ50 × 2-4h6h	50,00	49,72	0,28	48,701	48,589	0,112	47,691	47,457	0,234

<sup>a</sup> In accordance with ISO 965-1

Table 4 — Root radii for external threads

Dimensions in millimetres

Pitch $P$	Root radius $R$	
	max.	min.
1	0,18	0,15
1,25	0,226	0,188
1,5	0,271	0,225
2	0,361	0,300

### 6.1.2 4g6g external threads

Figure 2 illustrates the position and the form of the limit profiles (maximum and minimum) in relation to the basic profile (see ISO 5855-1).

Tables 4 and 5 specify the limit dimensions.

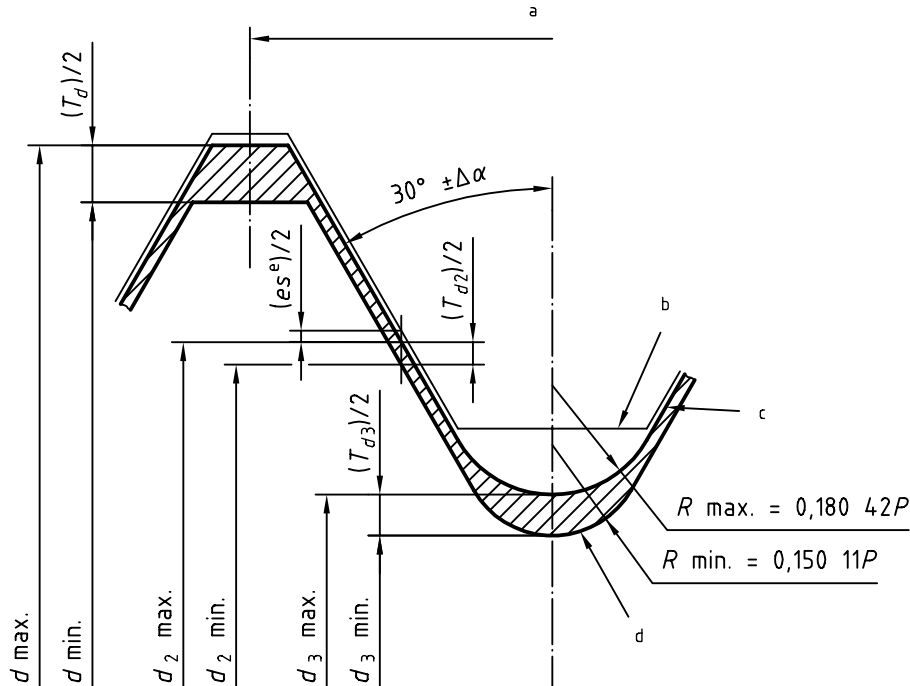

- a Pitch  $\pm \Delta P$
- b Basic profile
- c Maximum profile
- d Minimum profile
- e  $es$  is the basic upper deviation, see ISO 965-1

iTeh STANDARD PREVIEW  
(standards.iteh.ai)

ISO 5855-3:1999  
Figure 2 — Limit profiles for external threads (systematic clearance)

Table 5 — Limit dimensions for 4g6g external threads

Dimensions in millimetres

Thread designation	Major diameter $d$			Pitch diameter $d_2$			Minor diameter $d_3$		
	max.	min.	$T_d$ (6g) <sup>a</sup>	max.	min.	$T_{d_2}$ (4g) <sup>a</sup>	max.	min.	$T_{d_3}$
MJ8 × 1-4g6g	7,974	7,794	0,18	7,324	7,253	0,071	6,819	6,687	0,132
MJ10 × 1-4g6g	9,974	9,794	0,18	9,324	9,253	0,071	8,819	8,687	0,132
MJ12 × 1,25-4g6g	11,972	11,760	0,212	11,160	11,075	0,085	10,529	10,368	0,161
MJ14 × 1,5-4g6g	13,968	13,732	0,236	12,994	12,904	0,09	12,236	12,055	0,181
MJ16 × 1,5-4g6g	15,968	15,732	0,236	14,994	14,904	0,09	14,236	14,055	0,181
MJ18 × 1,5-4g6g	17,968	17,732	0,236	16,994	16,904	0,09	16,236	16,055	0,181
MJ20 × 1,5-4g6g	19,968	19,732	0,236	18,994	18,904	0,09	18,236	18,055	0,181
MJ22 × 1,5-4g6g	21,968	21,732	0,236	20,994	20,904	0,09	20,236	20,055	0,181
MJ24 × 1,5-4g6g	23,968	23,732	0,236	22,994	22,899	0,095	22,236	22,050	0,186
MJ27 × 1,5-4g6g	26,968	26,732	0,236	25,994	25,899	0,095	25,236	25,050	0,186
MJ30 × 1,5-4g6g	29,968	29,732	0,236	28,994	28,899	0,095	28,236	28,050	0,186
MJ33 × 1,5-4g6g	32,968	32,732	0,236	31,994	31,899	0,095	31,236	31,050	0,186
MJ36 × 1,5-4g6g	35,968	35,732	0,236	34,994	34,899	0,095	34,236	34,050	0,186
MJ39 × 1,5-4g6g	38,968	38,732	0,236	37,994	37,899	0,095	37,236	37,050	0,186
MJ42 × 2-4g6g	41,962	41,682	0,28	40,663	40,557	0,106	39,653	39,425	0,228
MJ48 × 2-4g6g	47,962	47,682	0,28	46,663	46,551	0,112	45,653	45,419	0,234
MJ50 × 2-4g6g	49,962	49,682	0,28	48,663	48,551	0,112	47,653	47,419	0,234

<sup>a</sup> In accordance with ISO 965-1

### 6.2 Internal threads

Figure 3 illustrates the position and the form of the limit profiles (maximum and minimum) in relation to the basic profile (see ISO 5855-1).

Table 6 specifies the limit dimensions.

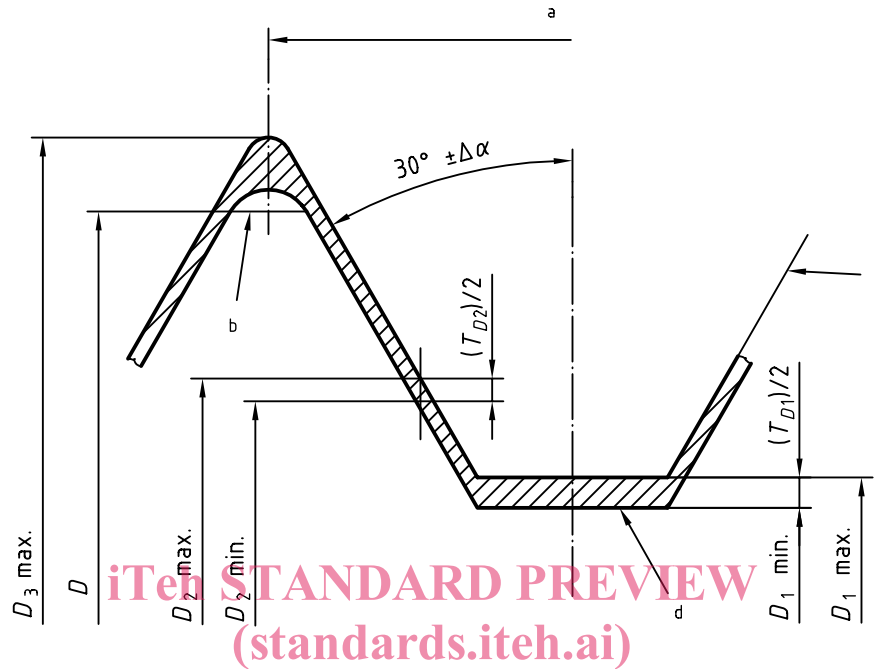

- a Pitch  $\pm \Delta P$
- b Basic profile
- c Maximum profile
- d Basic and minimum profiles

[ISO 5855-3:1999](https://standards.iteh.ai/catalog/standards/sist/e350af8e-f45f-4bc9-8240-50d56864ba29/iso-5855-3-1999)  
<https://standards.iteh.ai/catalog/standards/sist/e350af8e-f45f-4bc9-8240-50d56864ba29/iso-5855-3-1999>

Figure 3 — Limit profiles for internal threads

**Table 6 — Limit dimensions for 4H5H internal threads**

Dimensions in millimetres

Thread designation	Major diameter $D_3^a$  max.	Pitch diameter			Minor diameter		
		$D_2$		$T_{D2}$ (4H) b	$D_1$		$T_{D1}$ (5H) b
		max.	min.		max.	min.	
MJ8 × 1-4H5H	8,239	7,445	7,350	0,095	7,216	7,026	0,19
MJ10 × 1-4H5H	10,239	9,445	9,350	0,095	9,216	9,026	0,19
MJ12 × 1,25-4H5H	12,292	11,300	11,188	0,112	10,994	10,782	0,212
MJ14 × 1,5-4H5H	14,335	13,144	13,026	0,118	12,775	12,539	0,236
MJ16 × 1,5-4H5H	16,335	15,144	15,026	0,118	14,775	14,539	0,236
MJ18 × 1,5-4H5H	18,335	17,144	17,026	0,118	16,775	16,539	0,236
MJ20 × 1,5-4H5H	20,335	19,144	19,026	0,118	18,775	18,539	0,236
MJ22 × 1,5-4H5H	22,335	21,144	21,026	0,118	20,775	20,539	0,236
MJ24 × 1,5-4H5H	24,342	23,151	23,026	0,125	22,775	22,539	0,236
MJ27 × 1,5-4H5H	27,342	26,151	26,026	0,125	25,775	25,539	0,236
MJ30 × 1,5-4H5H	30,342	29,151	29,026	0,125	28,775	28,539	0,236
MJ33 × 1,5-4H5H	33,342	32,151	32,026	0,125	31,775	31,539	0,236
MJ36 × 1,5-4H5H	36,342	35,151	35,026	0,125	34,775	34,539	0,236
MJ39 × 1,5-4H5H	39,342	38,151	38,026	0,125	37,775	37,539	0,236
MJ42 × 2-4H5H	42,429	40,841	40,701	0,14	40,351	40,051	0,3
MJ48 × 2-4H5H	48,439	46,851	46,701	0,15	46,351	46,051	0,3
MJ50 × 2-4H5H	50,439	48,851	48,701	0,15	48,351	48,051	0,3

<sup>a</sup>  $D_3$  min. is not specified. However, it shall be greater than  $D_2$  (see Figure 3).  
<sup>b</sup> In accordance with ISO 965-1.

**6.3 Maximum permissible deviations on pitch (lead) and on half flank angle**

Values given in Table 7 have been taken from Table 6 of ISO 5855-1:1999.

**Table 7 — Maximum permissible deviations on pitch (lead) and on half flank angle**

Nominal diameter $d$ or $D$ mm	Pitch $P$ mm	External thread		Internal thread	
		$\Delta P$ $\mu\text{m}$	$\Delta\alpha$	$\Delta P$ $\mu\text{m}$	$\Delta\alpha$
8 10	1	16,4	1° 5'	21,9	1° 27'
12	1,25	19,6	1° 2'	25,9	1° 22'
14 16 18 20 22	1,5	20,8	0° 55'	27,3	1° 12'
24 27 30 33 36 39		21,9	0° 58'	28,9	1° 16'
42	2	24,5	0° 49'	32,3	1° 4'
48		25,9	0° 51'	34,6	1° 8'
50					



**iTeh STANDARD PREVIEW**  
**(standards.iteh.ai)**

ISO 5855-3:1999

<https://standards.iteh.ai/catalog/standards/sist/e350af8e-f45f-4bc9-8240-50d56864ba29/iso-5855-3-1999>