



Designation: C 289 – 03

## Standard Test Method for Potential Alkali-Silica Reactivity of Aggregates (Chemical Method)<sup>1</sup>

This standard is issued under the fixed designation C 289; the number immediately following the designation indicates the year of original adoption or, in the case of revision, the year of last revision. A number in parentheses indicates the year of last reapproval. A superscript epsilon ( $\epsilon$ ) indicates an editorial change since the last revision or reapproval.

*This standard has been approved for use by agencies of the Department of Defense.*

### 1. Scope\*

1.1 This test method covers chemical determination of the potential reactivity of an aggregate with alkalis in portland-cement concrete as indicated by the amount of reaction during 24 h at 80°C between 1 N sodium hydroxide solution and aggregate that has been crushed and sieved to pass a 300- $\mu$ m sieve and be retained on a 150- $\mu$ m sieve.

1.2 The values stated in SI units are to be regarded as standard.

1.3 *This standard does not purport to address all of the safety concerns, if any, associated with its use. It is the responsibility of the user of this standard to establish appropriate safety and health practices and determine the applicability of regulatory limitations prior to use.* A specific precautionary statement is given in 5.7.1.

### 2. Referenced Documents

#### 2.1 ASTM Standards:

- C 114 Test Methods for Chemical Analysis of Hydraulic Cement<sup>2</sup>
- C 227 Test Method for Potential Alkali Reactivity of Cement-Aggregate Combinations (Mortar-Bar Method)<sup>3</sup>
- C 295 Guide for Petrographic Examination of Aggregates for Concrete<sup>3</sup>
- C 702 Practice for Reducing Samples of Aggregate to Testing Size<sup>3</sup>
- C 1005 Specification for Reference Masses and Devices for Determining Mass and Volume for Use in the Physical Testing of Hydraulic Cements<sup>2</sup>
- C 1260 Test Method for Potential Alkali Reactivity of Aggregates (Mortar-Bar Method)<sup>3</sup>
- C 1293 Test Method for Determination of Length Change

of Concrete Due to Alkali-Silica Reaction<sup>3</sup>

D 75 Practice for Sampling Aggregates<sup>4</sup>

D 1193 Specification for Reagent Water<sup>5</sup>

D 1248 Specification for Polyethylene Plastics Extrusion Materials for Wire and Cable<sup>6</sup>

E 11 Specification for Wire Cloth and Sieves for Testing Purposes<sup>7</sup>

E 60 Practice for Analysis of Metals, Ores, and Related Materials by Molecular Absorption Spectrometry<sup>8</sup>

2.2 *American Chemical Society Documents:*

Reagent Chemicals, American Chemical Society Specifications

NOTE 1—For suggestions on the testing of reagents not listed by the American Chemical Society, see “Reagent Chemicals and Standards,” by Joseph Rosin, D. Van Nostrand Co., Inc., New York, NY, and the “United States Pharmacopeia.”

### 3. Significance and Use

3.1 When this test method is used to evaluate the potential reactivity of siliceous components in the aggregate with alkalis in hydraulic-cement concrete, it must be used in combination with other methods. Do not use the results of tests by this test method as the sole basis for acceptance or rejection for sources with regard to ASR.

3.2 Reactions between a sodium hydroxide solution and siliceous components in the aggregate have been shown to correlate with the performance of some aggregates in concrete structures. The results from this test method can be obtained quickly, and, while not completely reliable in all cases, they can provide useful data.

3.3 This test method can be employed as a quality control tool to periodically check samples from an existing source with an acceptable service history.

<sup>1</sup> This test method is under the jurisdiction of ASTM Committee C09 on Concrete and Concrete Aggregates and is the direct responsibility of Subcommittee C09.26 on Chemical Reactions of Materials.

Current edition approved Aug. 10, 2003. Published October 2003. Originally approved in 1952. Last previous edition approved in 2002 as C 289 – 02.

<sup>2</sup> *Annual Book of ASTM Standards*, Vol 04.01.

<sup>3</sup> *Annual Book of ASTM Standards*, Vol 04.02.

<sup>4</sup> *Annual Book of ASTM Standards*, Vol 04.03.

<sup>5</sup> *Annual Book of ASTM Standards*, Vol 11.01.

<sup>6</sup> *Annual Book of ASTM Standards*, Vol 08.01.

<sup>7</sup> *Annual Book of ASTM Standards*, Vol 14.02.

<sup>8</sup> *Annual Book of ASTM Standards*, Vol 03.05.

\*A Summary of Changes section appears at the end of this standard.

**4. Apparatus**

4.1 *Scales*—The scales and weights used for weighing materials shall conform to the requirements prescribed in Specification C 1005.

4.2 *Balances*—The analytical balance and weights used for determining dissolved silica by the gravimetric method shall conform to the requirements prescribed in Test Methods C 114.

4.3 *Crushing and Grinding Equipment*—A small jaw crusher and disk pulverizer or other suitable equipment capable of crushing and grinding aggregate to pass a 300- $\mu$ m sieve.

4.4 *Sieves*:

4.4.1 300- $\mu$ m and 150- $\mu$ m square-hole, woven wire-cloth sieves conforming to Specification E 11.

4.4.2 A 4.75-mm (No. 4) sieve.

4.5 *Containers*—Reaction containers of 50 to 75-mL capacity, made of corrosion-resistant steel or other corrosion-resistant material, and fitted with airtight covers. A container that has been found suitable is shown in Fig. 1. Other containers, made of corrosion-resistant material such as polyethylene, may be suitable. Such suitability can be demonstrated by a change in the alkalinity of the sodium hydroxide solution ( $R_c$ , Section on Reduction in Alkalinity) when used alone as a blank in the container in question, of less than 10 mmol/L.

4.6 *Constant-Temperature Bath*—A liquid bath capable of maintaining a temperature of  $80 \pm 1^\circ\text{C}$  for 24 h.

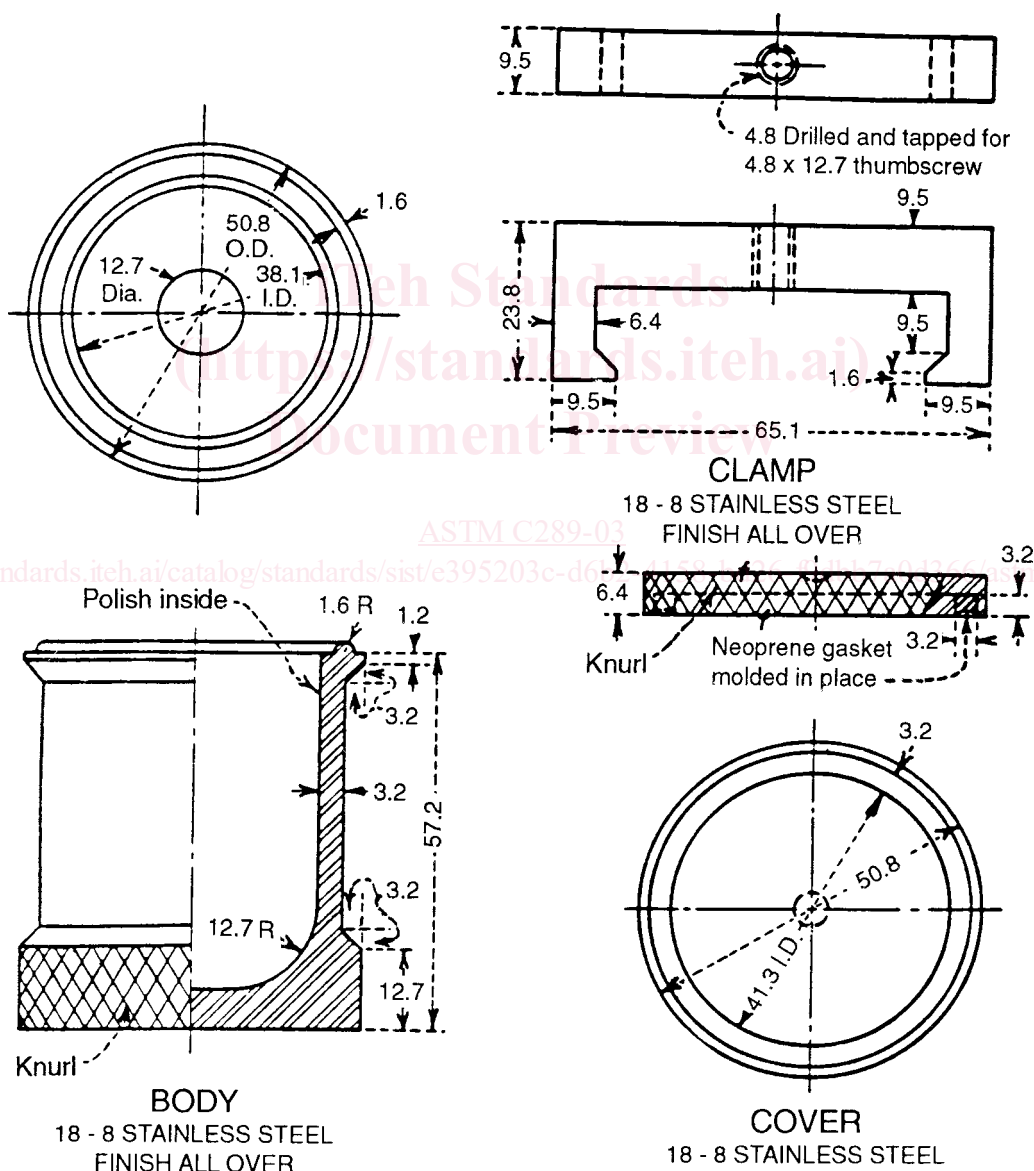

NOTE 1—All dimensions are in mm.

FIG. 1 Reaction Container

4.7 *Spectrophotometer or Photometer*—A spectrophotometer or photoelectric photometer capable of measuring the transmission of light at a constant wavelength of approximately 410 nm (see Practice E 60).

4.8 *Glassware*—All glass apparatus and vessels should be carefully selected to meet the particular requirements for each operation. Standard volumetric flasks, burets, and pipets should be of precision grade.

## 5. Reagents

5.1 *Purity of Reagents*—Reagent grade chemicals shall be used in all tests. Unless otherwise indicated, all reagents shall conform to the specifications of the Committee on Analytical Reagents of the American Chemical Society, where such specifications are available. Other grades may be used, provided it is first ascertained that the reagent is of sufficiently high purity to permit its use without lessening the accuracy of the determination.

5.2 *Purity of Water*—Unless otherwise indicated, references to water shall be understood to mean reagent water conforming to Type IV of Specification D 1193.

5.3 *Ammonium Molybdate Solution*—Dissolve 10 g of ammonium molybdate ( $(\text{NH}_4)_6 \text{Mo}_7\text{O}_{24} \cdot 4\text{H}_2\text{O}$ ) in 100 mL of water. If the solution is not clear, filter through a fine-texture paper. Store the solution in a polyethylene container (see Note 2).

5.4 *Hydrochloric Acid* (1.19 kg/L)—Concentrated hydrochloric acid (HCl). Store the solution in a chemically resistant glass or suitable plastic container (see Note 2).

5.5 *Hydrochloric Acid, Standard* (0.05 N)—Prepare approximately 0.05 N HCl and standardize to  $\pm 0.0001$  N. Store the solution in a chemically resistant glass or suitable plastic container (see Note 2).

5.6 *Hydrochloric Acid* (1 + 1)—Mix equal volumes of concentrated HCl (1.19 kg/L) and water. Store the solution in a chemically resistant glass or suitable plastic container (see Note 2).

5.7 *Hydrofluoric Acid* (approximately 50 % HF)—Concentrated hydrofluoric acid. Store in a polyethylene bottle (see Note 2).

5.7.1 **Warning**—Before using HF, review (1) the safety precautions for using HF, (2) first aid for burns, and (3) the emergency response to spills, as described in the manufacturer's Material Safety Data Sheet or other reliable safety literature. HF can cause very severe burns and injury to unprotected skin and eyes. Suitable personal protective equipment should always be used. These should include full-face shields, rubber aprons, and gloves impervious to HF. Gloves should be checked periodically for pin holes.

5.8 *Oxalic Acid Solution*—Dissolve 10 g of oxalic acid dihydrate in 100 mL of water. Store the solution in a chemically resistant glass or suitable plastic container (see Note 2).

5.9 *Phenolphthalein Indicator Solution*—Dissolve 1 g of phenolphthalein in 100 mL of ethanol (1 + 1). Store the solution in a chemically resistant glass or suitable plastic container (see Note 2).

5.10 *Silica Standard Solution*—Prepare a standard silica solution containing approximately 10 mmol of silica ( $\text{SiO}_2$ )/L by dissolving sodium metasilicate in water. Store the solution

in a polyethylene bottle. Use a 100-mL aliquot of the solution to determine its  $\text{SiO}_2$  content by the procedure described in 8.1.1-8.2.1. Do not use a standard silica solution older than 1 year, since dissolved ionic silica in such a solution slowly polymerizes, causing spuriously low photometric readings (see Note 2).

5.11 *Sodium Hydroxide, Standard Solution* ( $1.000 \pm 0.010$  N)—Prepare a  $1.000 \pm 0.010$  N sodium hydroxide (NaOH) solution and standardize to  $\pm 0.001$  N. Store the solution in a polyethylene bottle (Note 2). Protect the dry reagent and solution from contamination by carbon dioxide.

5.12 *Sulfuric Acid* (sp gr 1.84)—Concentrated sulfuric acid ( $\text{H}_2\text{SO}_4$ ). Store the solution in a chemically resistant glass container (see Note 2).

NOTE 2—In selecting the container, take care to ensure that the reagent will not be modified by reaction with the material composing the container, including pigments or other additives, or by transpiration of phases through the walls of the container. Containers with wall thickness not less than 0.51 mm and composed of high-density polyethylene meeting the requirements of Specification D 1248, for materials of Type III, Class A, are suitable.

## 6. Selection and Preparation of Test Samples

6.1 The test can be used for either fine or coarse aggregate, and when the fine and coarse aggregate are of the same material it can be used for the total aggregate.

6.2 Obtain the aggregate sample in accordance with Practice D 75. Use the sample sizes given in Table number 1 of Practice D 75.

6.2.1 For samples of aggregate with a nominal maximum size less than 19.0 mm, split the sample in half in accordance with Practice C 702. Crush one half as described in 6.2.3. Retain the other half for further testing if desired.

6.2.2 For samples of aggregate with a nominal maximum size 19.0 mm or larger, mix and quarter the sample in accordance with Practice C 702. Crush one quarter as described in 6.2.3. Retain the other three quarters of the sample for further testing if desired.

6.2.3 Crush the sample in a jaw-crusher using small portions at a time, retaining all fractions, until the sample passes a 4.75-mm (No. 4) sieve. Reduce the crushed sample to  $300 \pm 5$  g by splitting in accordance with Practice C 702.

6.3 Sieve the 300-g sample, discarding all material that passes the 150- $\mu\text{m}$  (No. 100) sieve. Crush or grind the sample in small portions using a disk pulverizer, rotary mill (rotating-puck) device, or mortar and pestle. To minimize the production of material passing the 150- $\mu\text{m}$  (No. 100) sieve, use several passes of the portion through the equipment, removing material passing the 300- $\mu\text{m}$  (No. 50) sieve before regrinding the remainder. If the amount of material retained on the 150- $\mu\text{m}$  (No. 100) sieve is less than 100 g after pulverizing the entire 300-g sample, discard the sample and pulverize a new 300-g sample (Note 3).

NOTE 3—An over-pulverized sample may not produce the correct chemical test results. A properly pulverized sample will have about 110 to 150 g of material remaining on the 150- $\mu\text{m}$  (No. 100) sieve after washing.

6.4 To ensure that all material finer than the 150- $\mu\text{m}$  sieve has been removed, wash the sample over a 150- $\mu\text{m}$  sieve. Do not wash more than 100 g over a 203-mm diameter sieve at one

time. Dry the washed sample at  $105 \pm 5^\circ\text{C}$  for  $20 \pm 4$  h. Cool the sample and again sieve on the 150- $\mu\text{m}$  sieve. If inspection of the sample indicates the presence of silty or clayey coatings on particles, repeat the washing and drying procedure, and sieve as before over the 150- $\mu\text{m}$  sieve. Reserve the portion retained on the 150- $\mu\text{m}$  sieve for the test sample.

## 7. Reaction Procedure

7.1 Weigh out three representative  $25.00 \pm 0.05$ -g portions of the dry 150- $\mu\text{m}$  to 300- $\mu\text{m}$  test sample prepared in accordance with Section 6. Place one portion in each of the three of the reaction containers, and add by means of a pipet, 25 mL of the 1.000 *N* NaOH solution. To a fourth reaction container, by means of a pipet, add 25 mL of the same NaOH solution to serve as a blank. Seal the four containers and gently swirl them to liberate trapped air.

7.2 Immediately after the containers have been sealed, place them in a liquid bath maintained at  $80 \pm 1.0^\circ\text{C}$ . After  $24 \pm \frac{1}{4}$  h, remove the containers from the bath and cool them, for  $15 \pm 2$  min, under running tap water having a temperature below  $30^\circ\text{C}$ .

7.3 Immediately after the containers have been cooled, open them and filter the solution from the aggregate residue. Use a porcelain Gooch crucible (see Note 4) with a disk of rapid, analytical-grade filter paper cut to fit the bottom of the crucible, setting the crucible in a rubber crucible holder in a funnel. Place a dry test tube, 35 to 50-mL capacity, in the filter flask to collect the filtrate, and seat the funnel in the neck of the filter flask. With the aspirator in operation or the vacuum line open, decant a small quantity of the solution onto the filter paper so it will seat properly in the crucible. Without stirring the contents of the container, decant the remaining free liquid into the crucible. When the decantation of the liquid has been completed, discontinue the vacuum and transfer the solids remaining in the container to the crucible and pack in place with the aid of a stainless-steel spatula. Then apply and adjust the vacuum to approximately 51 kPa. Continue the filtration until further filtration yields filtrate at the approximate rate of 1 drop every 10 s; reserve the filtrate for further tests. Record the total amount of time during which the vacuum is applied as the filtration time; make every effort to achieve an equal filtration time for all samples in a set, by uniformity of procedure in the assembly of the filtration apparatus and the packing of the solids in the crucible.

NOTE 4—Coors Size No. 4 Gooch crucibles, or equivalent, have been found satisfactory for this purpose.

7.4 Filter the blank according to the procedure described in 7.3. Apply the vacuum for a length of time equal to the average filtration time for the three specimens.

7.5 Immediately following the completion of filtration, stir the filtrate to assure homogeneity, then take by pipet an aliquot of 10 mL of the filtrate and dilute with water to 200 mL in a volumetric flask. Reserve this diluted solution for the determination of the dissolved  $\text{SiO}_2$  and the reduction in alkalinity.

7.6 If the diluted filtrate is not to be analyzed within 4 h following completion of the filtration, transfer the solution to a clean, dry polyethylene container and close the container by means of a stopper or tight-fitting cap or lid.

## 8. Dissolved Silica by the Gravimetric Method

### 8.1 Procedure:

8.1.1 Transfer by pipet 100 mL of the dilute solution (7.5) to an evaporating dish, preferably of platinum for speed in evaporation, add 5 to 10 mL of HCl (1.19 kg/L), and evaporate to dryness on a steam bath. Without heating the residue further, treat it with 5 to 10 mL of HCl (1.19 kg/L) and then an equal amount of water, or at once pour 10 to 20 mL of HCl (1 + 1) upon the residue. Cover the dish and digest for 10 min on the steam bath or a hot plate. Dilute the solution with an equal volume of hot water, filter immediately through quantitative-grade, low-ash filter paper, and wash the separated silica ( $\text{SiO}_2$ ) thoroughly with hot water (see Note 5) and reserve the residue.

NOTE 5—The washing of the  $\text{SiO}_2$  precipitates can be made more effective by using hot HCl (1 + 99) and then completing the washing with hot water.

8.1.2 Again evaporate the filtrate to dryness, baking the residue in an oven for 1 h at  $105$  to  $110^\circ\text{C}$ . Take up the residue with 10 to 15 mL of HCl (1 + 1) and heat on the bath or hot plate. Dilute the solution with an equal volume of hot water and catch and wash the small amount of  $\text{SiO}_2$  it contains on another filter paper. This second evaporation is necessary only when determining the concentration of the standard sodium metasilicate solution in 5.10. For the other test solutions, it can be eliminated.

8.1.3 Transfer the papers containing the residue (8.1.1 and 8.1.2) to a platinum crucible (see Note 6). Dry and ignite the papers, first at a low heat until the carbon of the filter paper is completely consumed without inflaming, and finally at  $1100$  to  $1200^\circ\text{C}$  until the mass remains constant.

NOTE 6—The mass of the empty crucible may be determined if one wishes to know the magnitude of impurities in the residue of  $\text{SiO}_2$ .

8.1.4 Treat the  $\text{SiO}_2$  thus obtained, which will contain small amounts of impurities, in the crucible with a few drops of water, about 10 mL of HF, and one drop of  $\text{H}_2\text{SO}_4$ , and evaporate cautiously to dryness on the steam bath. Finally, heat the small residue at  $1050$  to  $1100^\circ\text{C}$  for 1 to 2 min, cool, and determine the mass. The difference between this determination and that previously obtained represents the amount of  $\text{SiO}_2$ .

### 8.2 Calculation:

8.2.1 Calculate the  $\text{SiO}_2$  concentration of the NaOH solution filtered from the aggregate material, as follows:

$$S_c = 3330 \times W \quad (1)$$

where:

$S_c$  = concentration of  $\text{SiO}_2$  in mmol/L in the original filtrate, and

$W$  = grams of  $\text{SiO}_2$  found in 100 mL of the dilute solution.

## 9. Dissolved Silica by the Photometric Method

### 9.1 Application:

9.1.1 This method is applicable to the determination of crystalloidal (noncolloidal) silica (see Note 7) in all aqueous solutions except those with excessive color interferences (tannin and so forth), but it will not determine total silica. The