



SLOVENSKI STANDARD
SIST ISO 1922:2003

01-julij-2003

DYb^Yb]`dc`]a Yfb]`a UHf]U]`!`HfXY`dYbY!`8c`c Yj Ub^Y`glf]jybY`fXbcgh]

Rigid cellular plastics -- Determination of shear strength

Plastiques alvéolaires rigides -- Détermination de la résistance au cisaillement

Ta slovenski standard je istoveten z: **ISO 1922:2001**

[SIST ISO 1922:2003](https://standards.iteh.ai/catalog/standards/sist/72bab9a0-ef6d-4a00-a4b-9f4134f10992/sist-iso-1922-2003)

<https://standards.iteh.ai/catalog/standards/sist/72bab9a0-ef6d-4a00-a4b-9f4134f10992/sist-iso-1922-2003>

ICS:

83.100

Penjeni polimeri

Cellular materials

SIST ISO 1922:2003

en

iTeh STANDARD PREVIEW
(standards.iteh.ai)

SIST ISO 1922:2003

<https://standards.iteh.ai/catalog/standards/sist/72bab9a0-ef6d-4a00-af4b-9f4134f10992/sist-iso-1922-2003>

INTERNATIONAL STANDARD

**ISO
1922**

Third edition
2001-07-15

Rigid cellular plastics — Determination of shear strength

*Plastiques alvéolaires rigides — Détermination de la résistance au
cisaillement*

iTeh STANDARD PREVIEW
(standards.iteh.ai)

[SIST ISO 1922:2003](https://standards.iteh.ai/catalog/standards/sist/72bab9a0-ef6d-4a00-af4b-9f4134f10992/sist-iso-1922-2003)

[https://standards.iteh.ai/catalog/standards/sist/72bab9a0-ef6d-4a00-af4b-
9f4134f10992/sist-iso-1922-2003](https://standards.iteh.ai/catalog/standards/sist/72bab9a0-ef6d-4a00-af4b-9f4134f10992/sist-iso-1922-2003)



Reference number
ISO 1922:2001(E)

© ISO 2001

ISO 1922:2001(E)

PDF disclaimer

This PDF file may contain embedded typefaces. In accordance with Adobe's licensing policy, this file may be printed or viewed but shall not be edited unless the typefaces which are embedded are licensed to and installed on the computer performing the editing. In downloading this file, parties accept therein the responsibility of not infringing Adobe's licensing policy. The ISO Central Secretariat accepts no liability in this area.

Adobe is a trademark of Adobe Systems Incorporated.

Details of the software products used to create this PDF file can be found in the General Info relative to the file; the PDF-creation parameters were optimized for printing. Every care has been taken to ensure that the file is suitable for use by ISO member bodies. In the unlikely event that a problem relating to it is found, please inform the Central Secretariat at the address given below.

iTeh STANDARD PREVIEW (standards.iteh.ai)

[SIST ISO 1922:2003](https://standards.iteh.ai/catalog/standards/sist/72bab9a0-ef6d-4a00-af4b-9f4134f10992/sist-iso-1922-2003)

<https://standards.iteh.ai/catalog/standards/sist/72bab9a0-ef6d-4a00-af4b-9f4134f10992/sist-iso-1922-2003>

© ISO 2001

All rights reserved. Unless otherwise specified, no part of this publication may be reproduced or utilized in any form or by any means, electronic or mechanical, including photocopying and microfilm, without permission in writing from either ISO at the address below or ISO's member body in the country of the requester.

ISO copyright office
Case postale 56 • CH-1211 Geneva 20
Tel. + 41 22 749 01 11
Fax + 41 22 749 09 47
E-mail copyright@iso.ch
Web www.iso.ch

Printed in Switzerland

Contents

Page

Foreword.....	iv
1 Scope	1
2 Normative references	1
3 Principle.....	1
4 Apparatus	1
5 Test specimens.....	3
6 Number of test specimens.....	3
7 Conditioning and test temperature.....	3
8 Procedure	3
9 Calculation and expression of results.....	4
10 Precision and bias	4
11 Test report	5
Annex A (normative) Choice of adhesives for preparation of test specimens.....	6

STANDARD PREVIEW
(standards.iteh.ai)

SIST ISO 1922:2003

<https://standards.iteh.ai/catalog/standards/sist/72bab9a0-ef6d-4a00-af4b-9f4134f10992/sist-iso-1922-2003>

ISO 1922:2001(E)**Foreword**

ISO (the International Organization for Standardization) is a worldwide federation of national standards bodies (ISO member bodies). The work of preparing International Standards is normally carried out through ISO technical committees. Each member body interested in a subject for which a technical committee has been established has the right to be represented on that committee. International organizations, governmental and non-governmental, in liaison with ISO, also take part in the work. ISO collaborates closely with the International Electrotechnical Commission (IEC) on all matters of electrotechnical standardization.

International Standards are drafted in accordance with the rules given in the ISO/IEC Directives, Part 3.

Draft International Standards adopted by the technical committees are circulated to the member bodies for voting. Publication as an International Standard requires approval by at least 75 % of the member bodies casting a vote.

Attention is drawn to the possibility that some of the elements of this International Standard may be the subject of patent rights. ISO shall not be held responsible for identifying any or all such patent rights.

International Standard ISO 1922 was prepared by Technical Committee ISO/TC 61, *Plastics*, Subcommittee SC 10, *Cellular plastics*.

This third edition cancels and replaces the second edition (ISO 1922:1981), which has been technically revised.

Annex A forms a normative part of this International Standard.

SIST ISO 1922:2003
<https://standards.iteh.ai/catalog/standards/sist/72bab9a0-ef6d-4a00-af4b-9f4134f10992/sist-iso-1922-2003>

Rigid cellular plastics — Determination of shear strength

1 Scope

This International Standard specifies a method of determining the shear strength of rigid cellular plastics. It also provides for the optional determination of shear modulus.

2 Normative references

The following normative documents contain provisions which, through reference in this text, constitute provisions of this International Standard. For dated references, subsequent amendments to, or revisions of, any of these publications do not apply. However, parties to agreements based on this International Standard are encouraged to investigate the possibility of applying the most recent editions of the normative documents indicated below. For undated references, the latest edition of the normative document referred to applies. Members of ISO and IEC maintain registers of currently valid International Standards.

ISO 291:1997, *Plastics — Standard atmospheres for conditioning and testing*.

ISO 1923:1981, *Cellular plastics and rubbers — Determination of linear dimensions*.

[SIST ISO 1922:2003](https://standards.iteh.ai/catalog/standards/sist/72bab9a0-ef6d-4a00-af4b-9f4134f10992/sist-iso-1922-2003)

3 Principle

<https://standards.iteh.ai/catalog/standards/sist/72bab9a0-ef6d-4a00-af4b-9f4134f10992/sist-iso-1922-2003>

A shear stress is applied to a test specimen of defined shape by means of metal supports bonded to the specimen.

4 Apparatus

4.1 Test machine

The test machine (see Figure 1) shall be such that:

- a test specimen having the form and dimensions specified in clause 5 is held vertically between two fixing devices each comprising a metal support, one of these devices being fixed and the other movable, and the stress being transmitted along the longitudinal axis of the specimen;
- the movable grip will be moved away from the fixed grip at a constant rate of $(1 \pm 0,5)$ mm per minute in a direction parallel to the longitudinal axis of the specimen;
- the force exerted on the specimen shall be known with a maximum error of 1 %, and the distance between the grips shall be known with a maximum error of 0,01 mm, by means of recording devices.

4.2 Metal supports

These shall consist of flat, rectangular-sectioned, mild-steel plates, machined on one side, with a thickness of (16 ± 1) mm and a width of 50^{+1}_0 mm.

They shall be attached to the grips by the method shown in Figure 1.

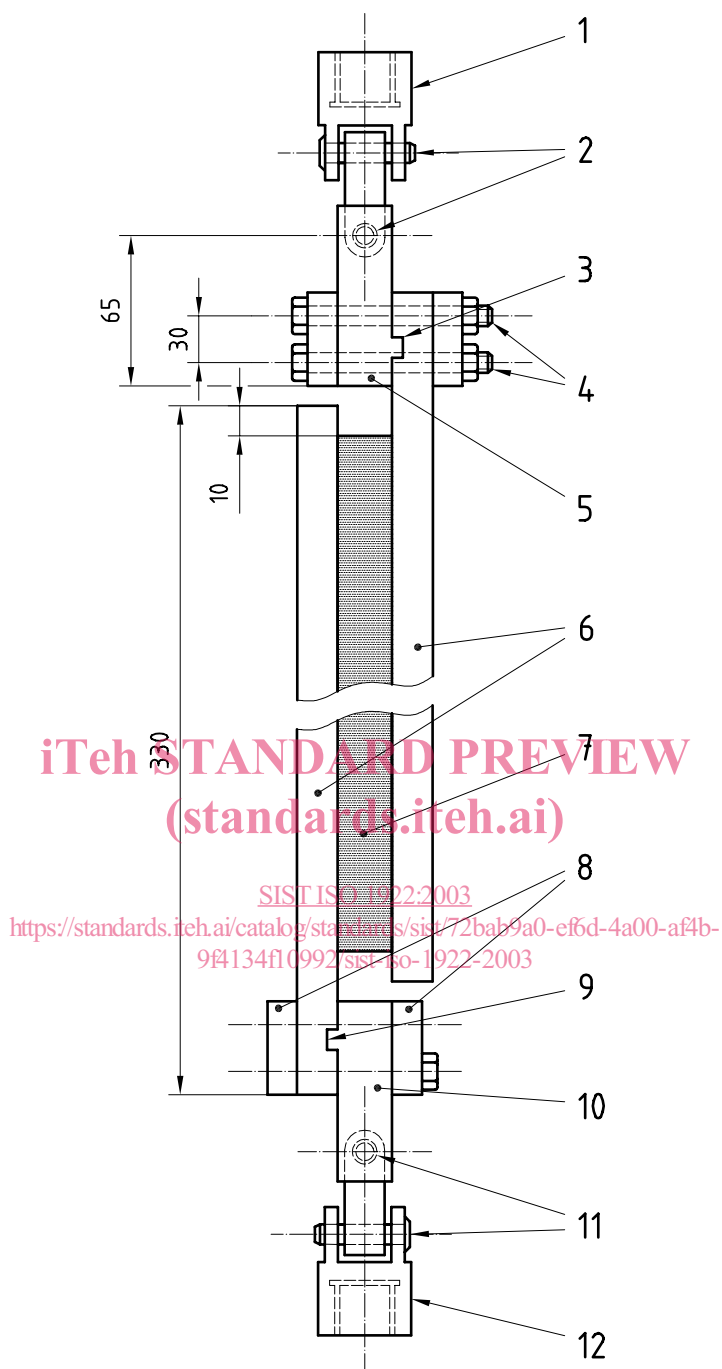
**Key**

- 1 Fixed machine grip
- 2 Universal-joint connection pins, allowing rotation about axis
- 3 Tongue and groove
- 4 Nut and bolt supports, \varnothing 10 mm
- 5 Adaptor
- 6 Metal supports
- 7 Test specimen
- 8 Load-spreading plates measuring (50 × 50 × 5) mm
- 9 Tongue and groove
- 10 Adaptor
- 11 Universal-joint connection pins, allowing rotation about axis
- 12 Movable machine grip

Figure 1 — Test assembly

The thickness of the adaptors that connect the metal supports to the test machine grips shall be equal to the thickness of the test specimen.

4.3 Adhesive

The adhesive used to fix the metal supports to the test specimen shall be such that the shear strength and modulus of the adhesive film are significantly greater than that of the cellular material under test, so as to ensure ultimate failure in the cellular material rather than at the adhesive interface. The adhesive shall also be compatible with the material under test. Details of a suitable adhesive and the method of application are given in annex A.

5 Test specimens

5.1 The test specimens shall be right parallelepipeds of the following dimensions:

- a) length: $250 \begin{smallmatrix} 0 \\ -5 \end{smallmatrix}$ mm;
- b) width: $50 \begin{smallmatrix} 0 \\ -1 \end{smallmatrix}$ mm;
- c) thickness: $(25 \pm 0,5)$ mm.

The distance between two parallel surfaces shall not vary by more than 1 %.

Measure the dimensions in accordance with the principles specified in ISO 1923.

5.2 Prepare test specimens without moulding skins. Machine their surfaces without modifying the original structure.

Bond the two machined surfaces of the metal supports to the larger surfaces of the dust-free test specimens so that the edges of the two metal supports are parallel to each other, as shown in Figure 1.

6 Number of test specimens

Test a set of five specimens. When testing materials suspected of being anisotropic, prepare sets of specimens having their major axes parallel with and normal to the suspected directions of anisotropy.

Reject specimens that fail at the adhesive interface before failure of the cellular material and test additional specimens so that the number of significant results is not less than five.

7 Conditioning and test temperature

Condition specimens immediately before testing for a period of not less than 16 h at a temperature of (23 ± 2) °C and at (50 ± 5) % relative humidity, in accordance with ISO 291.

Conduct the test at a temperature of (23 ± 2) °C.

8 Procedure

Attach a test specimen to the grips of the test machine and apply a force by separating the movable grip from the fixed grip at a rate of $(1 \pm 0,5)$ mm per minute, with a variation not greater than 10 % during the test.

Record the force-deflection diagram.