



**SLOVENSKI STANDARD**  
**SIST ISO 2896:2003**

01-julij-2003

---

DYb^Yb]`dc`]a Yfb]`a UHf]U]`!`HfXY`dYbY!`8c`c Yj Ub^Yj d]Ub^Uj cXY

Rigid cellular plastics -- Determination of water absorption

Plastiques alvéolaires rigides -- Détermination de l'absorption d'eau

Ta slovenski standard je istoveten z: **ISO 2896:2001**

[SIST ISO 2896:2003](https://standards.iteh.ai/catalog/standards/sist/a8861d46-4a60-4d08-874a-abdb6d733f59/sist-iso-2896-2003)

<https://standards.iteh.ai/catalog/standards/sist/a8861d46-4a60-4d08-874a-abdb6d733f59/sist-iso-2896-2003>

**ICS:**

83.100

Penjeni polimeri

Cellular materials

**SIST ISO 2896:2003**

**en**

**iTeh STANDARD PREVIEW**  
**(standards.iteh.ai)**

SIST ISO 2896:2003

<https://standards.iteh.ai/catalog/standards/sist/a8861d46-4a60-4d08-874a-abdb6d733f59/sist-iso-2896-2003>

# INTERNATIONAL STANDARD

**ISO  
2896**

Third edition  
2001-07-01

---

---

## Rigid cellular plastics — Determination of water absorption

*Plastiques alvéolaires rigides — Détermination de l'absorption d'eau*

**iTeh STANDARD PREVIEW**  
**(standards.iteh.ai)**

[SIST ISO 2896:2003](https://standards.iteh.ai/catalog/standards/sist/a8861d46-4a60-4d08-874a-abdb6d733f59/sist-iso-2896-2003)

<https://standards.iteh.ai/catalog/standards/sist/a8861d46-4a60-4d08-874a-abdb6d733f59/sist-iso-2896-2003>



Reference number  
ISO 2896:2001(E)

© ISO 2001

## ISO 2896:2001(E)

**PDF disclaimer**

This PDF file may contain embedded typefaces. In accordance with Adobe's licensing policy, this file may be printed or viewed but shall not be edited unless the typefaces which are embedded are licensed to and installed on the computer performing the editing. In downloading this file, parties accept therein the responsibility of not infringing Adobe's licensing policy. The ISO Central Secretariat accepts no liability in this area.

Adobe is a trademark of Adobe Systems Incorporated.

Details of the software products used to create this PDF file can be found in the General Info relative to the file; the PDF-creation parameters were optimized for printing. Every care has been taken to ensure that the file is suitable for use by ISO member bodies. In the unlikely event that a problem relating to it is found, please inform the Central Secretariat at the address given below.

## iTeh STANDARD PREVIEW (standards.iteh.ai)

SIST ISO 2896:2003

<https://standards.iteh.ai/catalog/standards/sist/a8861d46-4a60-4d08-874a-abdb6d733f59/sist-iso-2896-2003>

© ISO 2001

All rights reserved. Unless otherwise specified, no part of this publication may be reproduced or utilized in any form or by any means, electronic or mechanical, including photocopying and microfilm, without permission in writing from either ISO at the address below or ISO's member body in the country of the requester.

ISO copyright office  
Case postale 56 • CH-1211 Geneva 20  
Tel. + 41 22 749 01 11  
Fax + 41 22 749 09 47  
E-mail [copyright@iso.ch](mailto:copyright@iso.ch)  
Web [www.iso.ch](http://www.iso.ch)

Printed in Switzerland

## Contents

Page

Foreword.....	iv
1 Scope .....	1
2 Normative references .....	1
3 Principle.....	1
4 Materials .....	1
5 Apparatus .....	1
6 Specimens .....	4
7 Procedure .....	5
8 Corrections for swelling and cut surfaces.....	5
9 Expression of results .....	7
10 Precision and accuracy.....	8
11 Test report .....	9
Annex A (normative) Determination of average cell diameter (see 8.1.3.1) .....	10

iTeh STANDARD PREVIEW  
(standards.iteh.ai)

SIST ISO 2896:2003

<https://standards.iteh.ai/catalog/standards/sist/a8861d46-4a60-4d08-874a-abdb6d733f59/sist-iso-2896-2003>

**ISO 2896:2001(E)****Foreword**

ISO (the International Organization for Standardization) is a worldwide federation of national standards bodies (ISO member bodies). The work of preparing International Standards is normally carried out through ISO technical committees. Each member body interested in a subject for which a technical committee has been established has the right to be represented on that committee. International organizations, governmental and non-governmental, in liaison with ISO, also take part in the work. ISO collaborates closely with the International Electrotechnical Commission (IEC) on all matters of electrotechnical standardization.

International Standards are drafted in accordance with the rules given in the ISO/IEC Directives, Part 3.

Draft International Standards adopted by the technical committees are circulated to the member bodies for voting. Publication as an International Standard requires approval by at least 75 % of the member bodies casting a vote.

Attention is drawn to the possibility that some of the elements of this International Standard may be the subject of patent rights. ISO shall not be held responsible for identifying any or all such patent rights.

International Standard ISO 2896 was prepared by Technical Committee ISO/TC 61, *Plastics*, Subcommittee SC 10, *Cellular plastics*.

This third edition cancels and replaces the second edition (ISO 2896:1987), which has been technically revised.

Annex A forms a normative part of this International Standard.

SIST ISO 2896:2003  
<https://standards.iteh.ai/catalog/standards/sist/a8861d46-4a60-4d08-874a-abdb6d733f59/sist-iso-2896-2003>

# Rigid cellular plastics — Determination of water absorption

## 1 Scope

This International Standard specifies a method for the determination of the water absorption of rigid cellular plastics by measuring the buoyant force on a test specimen after immersion under a 50 mm head of water for 4 days. Corrections are specified to take account of any change in volume of the specimen and also to correct for the volume of water in the cut surface cells of the specimen. The water absorption is expressed as the average, for several specimens, of the percentage increase in volume relative to the original volume.

The method described is intended for quality control and for use in product specifications.

## 2 Normative references

The following normative documents contain provisions which, through reference in this text, constitute provisions of this International Standard. For dated references, subsequent amendments to, or revisions of, any of these publications do not apply. However, parties to agreements based on this International Standard are encouraged to investigate the possibility of applying the most recent editions of the normative documents indicated below. For undated references, the latest edition of the normative document referred to applies. Members of ISO and IEC maintain registers of currently valid International Standards.

ISO 291:1997, *Plastics — Standard atmospheres for conditioning and testing*

<https://standards.iteh.ai/catalog/standards/sist/a8861d46-4a60-4d08-874a->

ISO 1923:1981, *Cellular plastics and rubbers — Determination of linear dimensions*

## 3 Principle

The water absorption of a material is determined by measurement of the buoyant force on a specimen immersed in distilled water for a specified time.

## 4 Materials

4.1 **Distilled water**, de-aerated (by storage for at least 48 h after distillation), for use as the immersion liquid.

## 5 Apparatus

5.1 **Balance**, accurate to 0,1 g and capable of suspending the cage (5.2).

5.2 **Underwater-weighing cage**, made of a stainless material not attacked by distilled water and large enough to contain a test specimen. A sinker heavy enough to compensate for the upthrust produced by the test specimen shall be attached to the base of the cage. The cage shall be fitted with a means of suspending it from the balance. See Figure 1 for an example.

5.3 **Cylindrical vessel**, at least 250 mm in diameter and 250 mm in height.

5.4 **Low-permeability plastic film**, for example polyethylene.

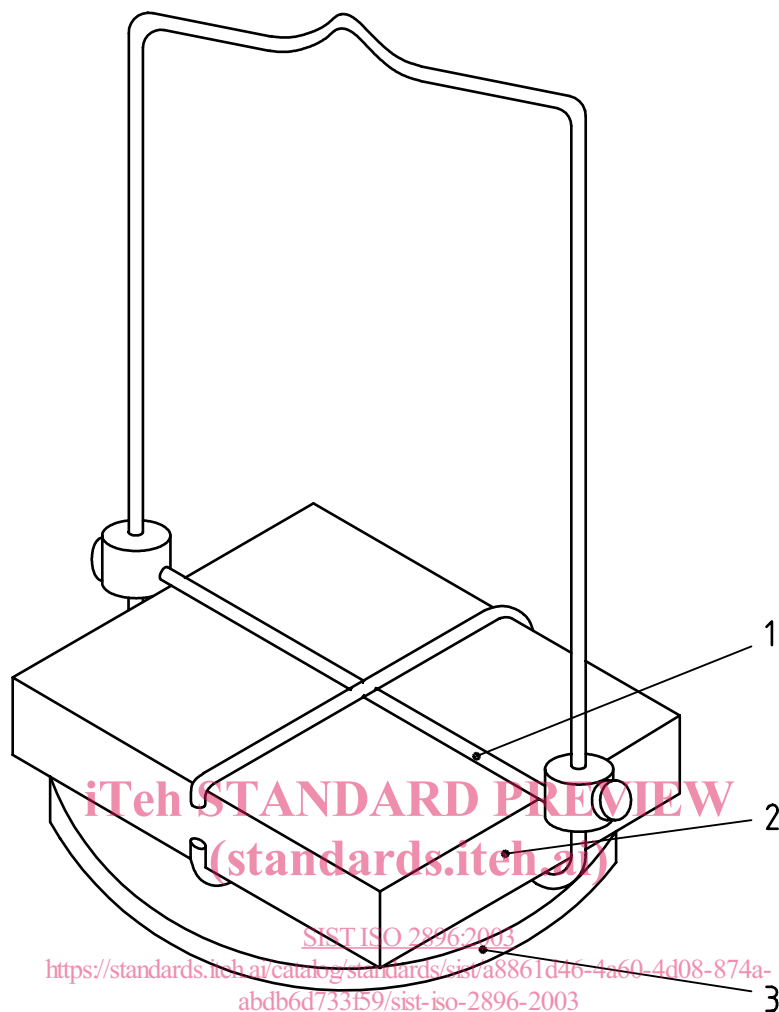

#### Key

- 1 Mesh cage
- 2 Specimen
- 3 Sinker

**Figure 1 — Test specimen in mesh underwater-weighing cage**

**5.5 Slicer:** cutting-blade apparatus capable of preparing thin specimens (0,1 mm to 0,4 mm thick) for cell size viewing. Figure 2 shows an acceptable apparatus.

**5.6 Slide assembly,** consisting of two pieces of slide glass hinged by tape along one edge, between which is placed a calibrated scale (3 cm in length) printed on a thin plastic sheet (see Figure 3).

**5.7 Projector:** conventional 35 mm slide projector that accepts standard 50 mm × 50 mm slides, or a projection microscope with a calibrated scale.



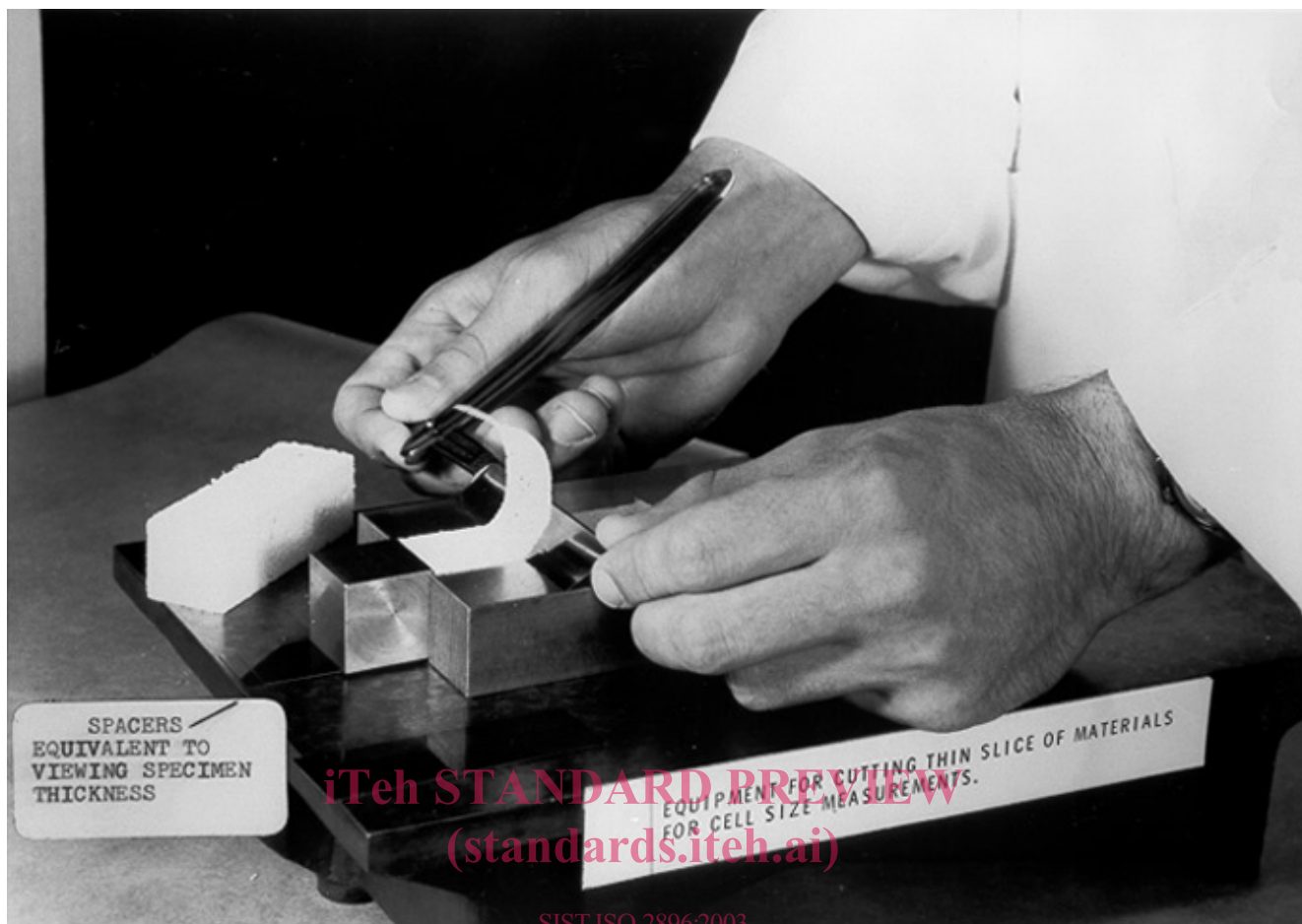

SIST ISO 2896:2003

NOTE <https://standards.iteh.ai/catalog/standards/sist/a8861d46-4a60-4d08-874a-ab06d755159/sist-iso-2896-2003>  
The spacer thickness is chosen to give the required viewing-specimen thickness.

Figure 2 — Razor-blade equipment for slicing cellular plastics for determination of average cell diameter