



**INTERNATIONAL STANDARD ISO 9409-1:1996
TECHNICAL CORRIGENDUM 1**

Published 1998-07-15

INTERNATIONAL ORGANIZATION FOR STANDARDIZATION • МЕЖДУНАРОДНАЯ ОРГАНИЗАЦИЯ ПО СТАНДАРТИЗАЦИИ • ORGANISATION INTERNATIONALE DE NORMALISATION

Manipulating industrial robots — Mechanical interfaces —

**Part 1:
Plates (form A)**

TECHNICAL CORRIGENDUM 1

Robots manipulateurs industriels — Interfaces mécaniques —

Partie 1: Interfaces à plateau (forme A)

RECTIFICATIF TECHNIQUE 1

**iTeh STANDARD PREVIEW
(standards.iteh.ai)**

Technical Corrigendum 1 to International Standard ISO 9409-1:1996 was prepared by Technical Committee ISO/TC 184, *Industrial automation systems and integration*, Subcommittee SC 2, *Robots for manufacturing environment*.

Page 3

Replace Figure 1 by the following.

ICS 25.040.30

Ref. No. ISO 9409-1:1996/Cor.1:1998(E)

© ISO 1998

Printed in Switzerland

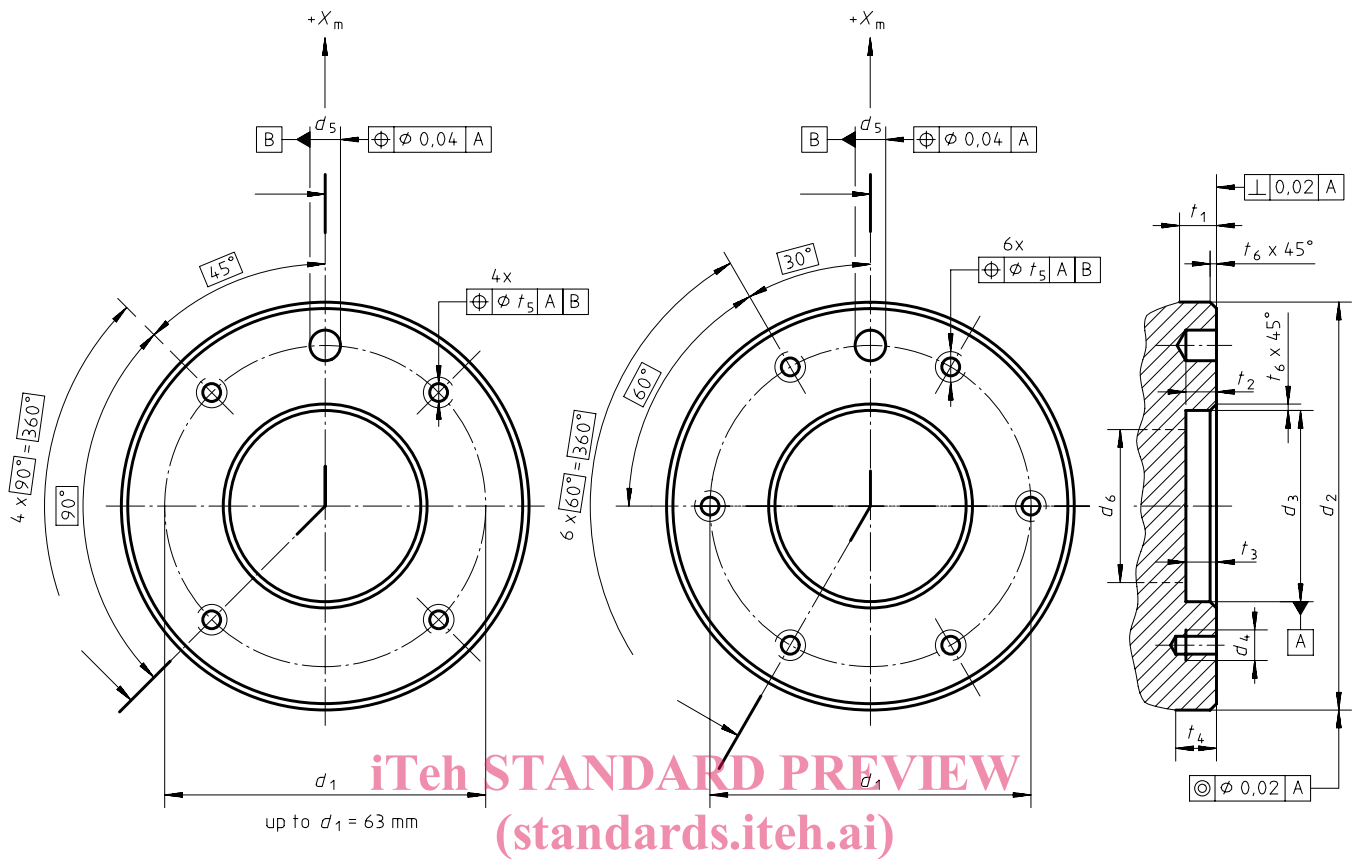

Figure 1 — Basic layout of the circular mechanical interface

ISO 9409-1:1996/Cor 1:1998

<https://standards.iteh.ai/catalog/standards/sist/91c39ca0-5b65-4753-9791-ca5445b68c44/iso-9409-1-1996-cor-1-1998>