



Designation: D 3663 – 03

## Standard Test Method for Surface Area of Catalysts and Catalyst Carriers<sup>1</sup>

This standard is issued under the fixed designation D 3663; the number immediately following the designation indicates the year of original adoption or, in the case of revision, the year of last revision. A number in parentheses indicates the year of last approval. A superscript epsilon ( $\epsilon$ ) indicates an editorial change since the last revision or reapproval.

### 1. Scope

1.1 This test method covers the determination of surface areas of catalyst and catalyst carriers that have Type II or IV nitrogen adsorption isotherms, and at least 1 m<sup>2</sup>/g of area. A volumetric measuring system is used to obtain at least four data points which fit on the linear BET<sup>2</sup> line.

1.2 The values stated in SI units are to be regarded as the standard. The values given in parentheses are for information only.

1.3 *This standard does not purport to address all of the safety concerns, if any, associated with its use. It is the responsibility of the user of this standard to establish appropriate safety and health practices and determine the applicability of regulatory limitations prior to use.*

### 2. Referenced Documents

#### 2.1 ASTM Standards:<sup>3</sup>

- D 3766 Terminology Relating to Catalysts and Catalysis
- E 177 Practice for Use of the Terms Precisions and Bias in ASTM Test Methods
- E 456 Terminology Relating to Quality and Statistics
- E 691 Practice for Conducting an Interlaboratory Study to Determine the Precision of a Test Method

### 3. Terminology

3.1 Consult Terminology D 3766 for definitions of other terms used.

#### 3.2 Definition:

3.2.1 *surface area of a catalyst*—the total surface of the catalyst. It is expressed in square metres per gram.

#### 3.3 Symbols:

$P_{H_1}$  = initial helium pressure, torr

$P_{H_2}$  = helium pressure after equilibration, torr  
 $T_{H_1}$  = temperature of manifold at initial helium pressure, °C  
 $T_{H_2}$  = temperature of manifold after equilibration, °C  
 $P_1$  = initial  $N_2$  pressure, torr  
 $T_1$  = manifold temperature at initial  $N_2$  pressure, K  
 $T_1'$  = manifold temperature at initial  $N_2$  pressure, °C  
 $P_2$  = pressure after equilibration, torr  
 $P_0$  = liquid nitrogen vapor pressure, torr  
 $T_s$  = liquid nitrogen temperature, K  
 $X$  = relative pressure,  $P_2/P_0$ <sup>3</sup>  
 $V_d$  = volume of manifold, cm<sup>3</sup>  
 $V_x$  = extra volume bulb, cm<sup>3</sup>  
 $V_s$  = dead-space volume, cm<sup>3</sup>  
 $W_s$  = mass of sample, g  
 $W_1$  = tare mass of sample tube, g  
 $W_2$  = sample + tare mass of tube, g  
 $V_{ds}$  = volume of nitrogen in the dead-space, cm<sup>3</sup>  
 $V_1$  = see 10.4.4  
 $V_2$  = see 10.4.6  
 $V_t$  = see 10.4.7  
 $V_a$  = see 10.4.9  
 $V_m$  = see 10.8  
 $T_{1x}$  = initial extra-volume bulb temperature, K  
 $T_{1x}'(i)$  = initial extra-volume bulb temperature, °C  
 $T_{2x}$  = extra-volume bulb temperature after equilibrium, K  
 $T_{2x}'(i)$  = extra-volume bulb temperature after equilibrium, °C

### 4. Summary of Method

4.1 The surface area of a catalyst or catalyst carrier is determined by measuring the volume of nitrogen gas adsorbed at various low-pressure levels by the catalyst sample. Pressure differentials caused by introducing the catalyst surface area to a fixed volume of nitrogen in the test apparatus are measured and used to calculate BET surface area.

### 5. Apparatus<sup>4</sup>

5.1 A schematic diagram of the apparatus is shown in Fig. 1. It may be constructed of glass or of metal. It has the following features:

5.1.1 *Distribution Manifold*, having a volume between 20 and 35 cm<sup>3</sup>, ( $V_d$ ), known to the nearest 0.05 cm<sup>3</sup>. This volume

<sup>4</sup> Automated equipment is commercially available.

<sup>1</sup> This test method is under the jurisdiction of ASTM Committee D32 on Catalysts and is the direct responsibility of Subcommittee D32.01 on Physical-Chemical Properties.

Current edition approved Oct. 1, 2003. Published October 2003. Originally approved in 1978. Last previous edition approved in 1999 as D 3663-99.

<sup>2</sup> Brunauer, Emmett, Teller, *Journal of American Chemical Society*, JACS, No. 60, 1938, p. 309.

<sup>3</sup> For referenced ASTM standards, visit the ASTM website, www.astm.org, or contact ASTM Customer Service at service@astm.org. For *Annual Book of ASTM Standards* volume information, refer to the standard's Document Summary page on the ASTM website.

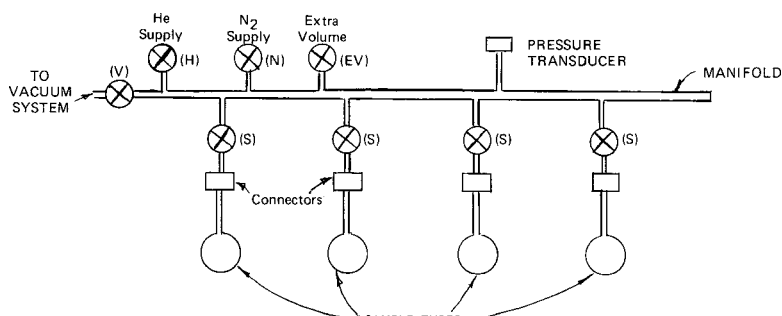

FIG. 1 Schematic Diagram of Surface Area Apparatus

is defined as the volume between the stopcocks or valves and includes the pressure gage.

5.1.2 *Vacuum System*, capable of attaining pressures below  $10^{-4}$  torr (1 torr = 133.3 Pa). This will include a vacuum gage (not shown in Fig. 1). Access to the distribution manifold is through the valve V.

5.1.3 *Constant-Volume Gage or Mercury Manometer*, capable of measurements to the nearest 0.1 torr, in the range from 0 to 1000 torr (1 torr = 133.3 Pa).

NOTE 1—See, for example, the article by Joy<sup>5</sup> for a description of a constant-volume manometer.

5.1.4 *Valve (H)*, from the helium supply to the distribution manifold.

5.1.5 *Valve (N)*, from the nitrogen supply to the distribution manifold.

5.1.6 The connection between the sample tube and the S valve can be a standard-taper glass joint, a glass-to-glass seal, or a compression fitting.

5.1.7 *Extra Volume Bulb*, ( $V_x$ ), should be 100 to 150 cm<sup>3</sup>, known to the nearest 0.05 cm<sup>3</sup>.  $V_x$  includes the volume of the stopcock bore in the glass apparatus.

5.2 *Sample Tubes*, with volumes from 5 to 100 cm<sup>3</sup> depending on the application. Markings should be placed on the sample tubes about 30 to 50 mm below the connectors to indicate the desired liquid nitrogen level.

5.3 *Heating Mantles or Small Furnaces*.

5.4 *Dewar Flasks*.

5.5 *Laboratory Balance*, with 0.1-mg ( $10^{-7}$ -kg) sensitivity.

5.6 *Thermometer or Thermocouple*, for measuring the temperature of the distribution manifold [ $T_1'(i)$  or  $T_2'(i)$ ] in degrees Celsius.

5.6.1 It is preferred that the manifold be thermostated at a particular temperature, a few degrees above ambient, to obviate the necessity of recording this temperature at each reading.

5.7 *Thermometer*, for measuring the temperature of the liquid nitrogen bath [ $T_s(i)$ ] in kelvins. This will preferably be a nitrogen vapor-pressure thermometer, often referred to in a commercial instrument as a pressure saturation tube, from which  $P_0$  values may be derived.

## 6. Reagents

6.1 *Purity of Reagents*—Reagent grade chemicals shall be used in all tests. Unless otherwise indicated, it is intended that

all reagents shall conform to the specifications of the Committee on Analytical Reagents of the American Chemical Society, where such specifications are available.<sup>6</sup> Other grades may be used, provided it is first ascertained that the reagent is of sufficiently high purity to permit its use without lessening the accuracy of the determination.

6.2 *Helium Gas*—A cylinder of helium gas at least 99.9 % pure.

6.3 *Liquid Nitrogen*, of such purity that  $P_0$  is not more than 20 torr above barometric pressure. A fresh daily supply is recommended.

6.4 *Nitrogen Gas*—A cylinder of nitrogen gas at least 99.999 % pure.

## 7. Procedure—Sample Preparation and Degassing

7.1 Select a sample tube of the desired size. A 5-cm<sup>3</sup> sample tube is preferred for samples not exceeding about 1 g, to minimize the dead-space. However, a 25-cm<sup>3</sup> sample tube may be preferred for finely powdered catalysts, to avoid “boiling” when degassing is started.

7.2 Fill the sample tube with nitrogen or helium, at atmospheric pressure, after removing air by evacuation. This may be done on the surface area unit, or on a separate piece of equipment.

7.3 Remove the sample tube from the system, cap, and weigh. Record the mass as  $W_1$ .

7.4 Place the catalyst sample, whose mass is known approximately, into the sample tube. Choose the sample size to provide an estimated total sample surface area of 20 to 100 m<sup>2</sup>.

7.5 Attach the sample tube to the apparatus. If other samples are to be run, attach them at this time to the other ports.

7.6 Open the S valves where there are samples.

7.7 It may be necessary to close the V valve system periodically to protect the diffusion pump fluid from exposure to pressures above 0.1 torr for periods of more than 30 s. Close the valve off for 2 min.

7.8 Install a heating mantle or furnace around each sample and raise the temperature to about 300°C (573 K).

NOTE 2—Take special precautions if the moisture content exceeds

<sup>5</sup> Joy, A. S., *Vacuum*, Vol 3, 1953, p. 254.

<sup>6</sup> *Reagent Chemicals, American Chemical Society Specifications*, American Chemical Society, Washington, DC. For suggestions on the testing of reagents not listed by the American Chemical Society, see *Annual Standards for Laboratory Chemicals*, BDH Ltd., Poole, Dorset, U.K., and the *United States Pharmacopeia and National Formulary*, U.S. Pharmacopeial Convention, Inc. (USPC), Rockville, MD.