**Information technology — Radio
frequency identification (RFID) for item
management — Data protocol: data
encoding rules and logical memory
functions**

*Technologies de l'information — Identification par radiofréquence
(RFID) pour la gestion d'objets — Protocole de données: règles
d'encodage des données et fonctions logiques de mémoire*

iTeh STANDARD PREVIEW
(standards.iteh.ai)

ISO/IEC 15962:2004

<https://standards.iteh.ai/catalog/standards/sist/0c97ea38-0c08-4c93-bb4f-5af8b6352bfc/iso-iec-15962-2004>

PDF disclaimer

This PDF file may contain embedded typefaces. In accordance with Adobe's licensing policy, this file may be printed or viewed but shall not be edited unless the typefaces which are embedded are licensed to and installed on the computer performing the editing. In downloading this file, parties accept therein the responsibility of not infringing Adobe's licensing policy. The ISO Central Secretariat accepts no liability in this area.

Adobe is a trademark of Adobe Systems Incorporated.

Details of the software products used to create this PDF file can be found in the General Info relative to the file; the PDF-creation parameters were optimized for printing. Every care has been taken to ensure that the file is suitable for use by ISO member bodies. In the unlikely event that a problem relating to it is found, please inform the Central Secretariat at the address given below.

iTeh STANDARD PREVIEW
(standards.iteh.ai)

[ISO/IEC 15962:2004](https://standards.iteh.ai/catalog/standards/sist/0c97ea38-0c08-4c93-bb4f-5af8b6352bfc/iso-iec-15962-2004)

<https://standards.iteh.ai/catalog/standards/sist/0c97ea38-0c08-4c93-bb4f-5af8b6352bfc/iso-iec-15962-2004>

© ISO/IEC 2004

All rights reserved. Unless otherwise specified, no part of this publication may be reproduced or utilized in any form or by any means, electronic or mechanical, including photocopying and microfilm, without permission in writing from either ISO at the address below or ISO's member body in the country of the requester.

ISO copyright office
Case postale 56 • CH-1211 Geneva 20
Tel. + 41 22 749 01 11
Fax + 41 22 749 09 47
E-mail copyright@iso.org
Web www.iso.org

Published in Switzerland

Contents

Page

Foreword.....	vi
Introduction	vii
1 Scope.....	1
2 Normative references	1
3 Terms, definitions and abbreviated terms.....	2
3.1 Terms and definitions.....	2
3.2 Abbreviated terms.....	4
4 Protocol model	4
4.1 Overview	4
4.2 Layered protocol	5
4.3 Functional processes	6
5 Data structure	8
5.1.1 The 8-bit byte.....	8
5.1.2 N-bit encoding.....	8
6 Data Protocol Processor and the application interface.....	8
6.1 Processing transfers from ISO/IEC 15961.....	9
6.2 Universal Types.....	9
6.3 Length encoding and decoding.....	10
6.4 Decoding of Type values.....	10
6.4.1 Decoding of a BOOLEAN value.....	10
6.4.2 Decoding an INTEGER value.....	10
6.4.3 Decoding an OBJECT IDENTIFIER value.....	11
6.4.4 Decoding the OCTET STRING value.....	11
6.4.5 Decoding the SEQUENCE or SEQUENCE OF value.....	11
7 Data Protocol Processor and the air interface.....	12
7.1 Air interface services.....	12
7.2 Defining the system information	13
7.2.1 Tag Identifier.....	13
7.2.2 Physical block size	14
7.2.3 Number of blocks.....	14
7.2.4 Application Family Identifier.....	14
7.2.5 Storage Format.....	14
7.3 Configuring the Logical Memory.....	15
7.3.1 Non- directory structure of the Logical Memory	15
7.3.2 Directory structure of the Logical Memory	16
7.3.3 Self mapping RF tags	16
8 Data flows and processes.....	17
8.1 Application data	17
8.1.1 Processing data transferred from ISO/IEC 15961	17
8.1.2 Processing example	18
8.2 Data object processing.....	19
8.2.1 Compaction process.....	19
8.2.2 Compaction Schemes.....	20
8.2.3 Compaction Type codes.....	21
8.2.4 Encoding the length of the compacted object.....	21
8.2.5 Example of encoding for the Logical Memory after compaction.....	21
8.3 Data formatting.....	22
8.3.1 Data Formatter Functions	22

8.3.2	Formatting the objectId	23
8.3.3	The Precursor for dataFormat not equal 2	24
8.3.4	The Precursor for the root-OID for dataFormat = 2	24
8.3.5	Encoding the RELATIVE-OID	24
8.3.6	Encoding the OBJECT IDENTIFIER	26
8.3.7	Encoding the root-OID for dataFormat = rootOidEncoded (2).....	26
8.3.8	Encoding the object and its length.....	27
8.3.9	The offset byte	27
8.3.10	The Precursor expansion byte.....	27
8.3.11	The directory structure	27
8.3.12	Addressing from the directory.....	28
8.3.13	Structures of Logical Memory.....	28
8.4	Decoding the Logical Memory	28
8.4.1	Overall decode strategy.....	28
8.4.2	Decoding the storageFormat	28
8.4.3	Decoding the Precursor.....	29
8.4.4	Decoding the leading byte(s) of the encoded objectId.....	30
9	The Command / Response unit.....	31
9.1	Commands	31
9.1.1	Configure Application Family Identifier command.....	31
9.1.2	Configure Storage Format command.....	31
9.1.3	Inventory Tags command.....	32
9.1.4	Add Single Object command	32
9.1.5	Delete Object command	32
9.1.6	Modify Object command.....	32
9.1.7	Read Single Object command	33
9.1.8	Read ObjectIds command	33
9.1.9	Read All Objects command.....	34
9.1.10	Read Logical Memory Map command.....	34
9.1.11	Inventory And Read Objects command.....	34
9.1.12	Erase Memory command.....	35
9.1.13	Get Application-based System Information command.....	35
9.1.14	Add Multiple Objects command.....	35
9.1.15	Read Multiple Objects command.....	35
9.1.16	Read First Object command.....	36
9.2	Processing arguments.....	36
9.2.1	afiLock	36
9.2.2	avoidDuplicate	36
9.2.3	checkDuplicate	37
9.2.4	identifyMethod and numberOfTags.....	37
9.2.5	lockStatus	38
9.2.6	maxAppLength	38
9.2.7	objectLock.....	38
9.2.8	storageFormatLock.....	38
9.3	Completion codes	39
9.4	Execution codes	40
10	Communications between the Data Protocol and the RF tag.....	41
11	Compliance, or classes of compliance, to this International Standard.....	41
11.1	Compliance of the Data Protocol Processor	41
11.2	Compliance of the Tag Driver	41
Annex A	(normative) Pro Forma Description for the Tag Driver	42
A.1	Defining the tagId	42
A.2	System information : applicationFamilyId.....	42
A.3	System information : storageFormat	42
A.4	Memory-related parameters	42
A.5	Support for commands	43

THE STANDARD PREVIEW
 (standards.iteh.ai)
 ISO/IEC 15962:2004
<http://standards.iteh.ai/catalog/standards/sist/0c97ca38-0c08-4c95-bb4f-5a1800352b1c/iso-iec-15962-2004>

Annex B (normative) ISO/IEC 18000 Tag Driver Descriptions	44
B.1 Tag Driver for ISO/IEC 18000-2: Parameters for Air Interface Communications below 135 kHz	44
B.2 Tag Driver for Mode 1 of ISO/IEC 18000-3: Parameters for Air Interface Communications at 13,56 MHz	45
B.3 Tag Driver for Mode 2 of ISO/IEC 18000-3: Parameters for Air Interface Communications at 13,56 MHz	46
B.4 Tag Driver for ISO/IEC 18000-4: Parameters for Air Interface Communications at 2,45 GHz - Mode 1	47
B.5 Tag Driver for ISO/IEC 18000-4: Parameters for Air Interface Communications at 2,45 GHz - Mode 2	48
B.6 Tag Driver for ISO/IEC 18000-6: Parameters for Air Interface Communications at 860 MHz to 960 MHz	49
Annex C (normative) Data Compaction Schemes	51
C.1 Integer compaction	51
C.2 Numeric compaction	51
C.3 5-bit compaction	52
C.4 6-bit compaction	52
C.5 7-bit compaction	53
C.6 Octet encodation	54
Annex D (normative) ISO/IEC 646 Characters Supported by the Compaction Schemes	55
Annex E (informative) Encoding Example	59
E.1 Starting position	59
E.2 The initial state of the entry for the Logical Memory	59
E.3 The Logical Memory after data compaction	59
E.4 The Logical Memory after formatting with a noDirectory accessMethod	60
Annex F (informative) Logical Memory Structures	62
F.1 Notation	62
F.2 Non-directory structured Logical Memory with root-OID implicitly encoded	62
F.3 Non-directory structured Logical Memory with root-OID explicitly encoded	63
F.4 Directory structured Logical Memory with root-OID implicitly encoded	63
F.5 Directory structured Logical Memory with root-OID explicitly encoded	63

Foreword

ISO (the International Organization for Standardization) and IEC (the International Electrotechnical Commission) form the specialized system for worldwide standardization. National bodies that are members of ISO or IEC participate in the development of International Standards through technical committees established by the respective organization to deal with particular fields of technical activity. ISO and IEC technical committees collaborate in fields of mutual interest. Other international organizations, governmental and non-governmental, in liaison with ISO and IEC, also take part in the work. In the field of information technology, ISO and IEC have established a joint technical committee, ISO/IEC JTC 1.

International Standards are drafted in accordance with the rules given in the ISO/IEC Directives, Part 2.

The main task of the joint technical committee is to prepare International Standards. Draft International Standards adopted by the joint technical committee are circulated to national bodies for voting. Publication as an International Standard requires approval by at least 75 % of the national bodies casting a vote.

Attention is drawn to the possibility that some of the elements of this document may be the subject of patent rights. ISO and IEC shall not be held responsible for identifying any or all such patent rights.

ISO/IEC 15962 was prepared by Joint Technical Committee ISO/IEC JTC 1, *Information technology*, Subcommittee SC 31, *Automatic identification and data capture techniques*.

ITEH STANDARD PREVIEW

(standards.iteh.ai)

ISO/IEC 15962:2004

<https://standards.iteh.ai/catalog/standards/sist/0c97ea38-0c08-4c93-bb4f-5af8b6352bfc/iso-iec-15962-2004>

Introduction

The technology of Radio Frequency Identification (RFID) is based on non-contact electronic communication across an air interface. The structure of the bits stored on the memory of the RF tag is invisible and accessible between the RF tag and the interrogator only by the use of the appropriate air interface protocol, as specified in the different ISO/IEC 18000 parts. The transfer of data between the application and the interrogator in open systems requires data to be presented in a consistent manner on any RF tag that is part of that open system. Functional commands from the application and responses from the interrogator also require being processed in a standard way. This is not only to allow equipment to be interoperable, but in the special case of data carrier, for the data to be encoded on the RF tag in one systems implementation for it to be read at a later time in a completely different and unknown systems implementation. The data bits stored on each RF tag must be formatted in such a way as to be reliably read at the point of use if the RF tag is to fulfil its basic objective. The integrity of this is achieved through the use of a data protocol as specified in ISO/IEC 15961 and this International Standard.

Manufacturers of radio frequency identification equipment (interrogators, RF tags, etc) and the users of RFID technology require a publicly available data protocol for RFID for item management. ISO/IEC 15961 and this International Standard specify this data protocol, which is independent of any of the air interface standards defined in the various parts of ISO/IEC 18000. As such, the data protocol is a consistent component in the RFID system that may independently evolve to include additional air interface protocols

The transfer of data to and from the application, supported by appropriate commands is the subject of the companion standard: ISO/IEC 15961. This International Standard specifies the overall process and the methodologies developed to format the application data into a structure to store on the RF tag.

[ISO/IEC 15962:2004](https://standards.iteh.ai/catalog/standards/sist/0c97ea38-0c08-4c93-bb4f-5af8b6352bfc/iso-iec-15962-2004)

<https://standards.iteh.ai/catalog/standards/sist/0c97ea38-0c08-4c93-bb4f-5af8b6352bfc/iso-iec-15962-2004>

iTeh STANDARD PREVIEW
(standards.iteh.ai)

[ISO/IEC 15962:2004](#)

<https://standards.iteh.ai/catalog/standards/sist/0c97ea38-0c08-4c93-bbf4-5af8b6352bfc/iso-iec-15962-2004>

Information technology — Radio frequency identification (RFID) for item management — Data protocol: data encoding rules and logical memory functions

1 Scope

The data protocol used to exchange information in an RFID system for item management is specified in ISO/IEC 15961 and in this International Standard. Both International Standards are required for a complete understanding of the data protocol in its entirety; but each focuses on one particular interface:

- ISO/IEC 15961 addresses the interface with the application system.
- This International Standard deals with the processing of data and its presentation to the RF tag, and the initial processing of data captured from the RF tag.

This International Standard focuses on encoding the transfer syntax, as defined in ISO/IEC 15961 according to the application commands defined in that International Standard. The encodation is in a Logical Memory as a software analogue of the physical memory of the RF tag being addressed by the interrogator.

This International Standard

[ISO/IEC 15962:2004](https://standards.iteh.ai/catalog/standards/sist/0c97ea38-0c08-4c93-bb44-62-2004)

<https://standards.iteh.ai/catalog/standards/sist/0c97ea38-0c08-4c93-bb44-62-2004>

- defines the encoded structure of object identifiers;
- specifies the data compaction rules that apply to the encoded data;
- specifies a Precursor for encoding syntax features efficiently;
- specifies formatting rules for the data, e.g. depending on whether a directory is used or not;
- defines how application commands, e.g. to lock data, are transferred to the Tag Driver;
- defines other communication to the application.

NOTE Conventionally in International Standards, long numbers are separated by a space character as a "thousands separator". This convention has not been followed in this International Standard, because the arcs of an object identifier are defined by a space separator (according to ISO/IEC 8824 and ISO/IEC 8825). As the correct representation of these arcs is vital to this International Standard, all numeric values have no space separators except to denote a node between two arcs of an object identifier.

2 Normative references

The following referenced documents are indispensable for the application of this document. For dated references, only the edition cited applies. For undated references, the latest edition of the referenced document (including any amendments) applies.

ISO/IEC 8824-1, *Information technology — Abstract Syntax Notation One (ASN.1) — Specification of basic notation* (equivalent to ITU-T Recommendation X.680)

ISO/IEC 8825-1, *Information technology — ASN.1 encoding rules — Specification of Basic Encoding Rules (BER), Canonical Encoding Rules (CER) and Distinguished Encoding Rules (DER)* (equivalent to ITU-T Recommendation X.690)

ISO/IEC 15961:2004, *Information technology — Radio frequency identification (RFID) for item management — Data protocol: application interface*

ISO/IEC 18000 (all parts), *Information technology — Radio frequency identification for item management*

ISO/IEC 19762-1, *Information technology — Automatic identification and data capture (AIDC) techniques — Harmonized vocabulary — Part 1: General terms for AIDC¹⁾*

ISO/IEC 19762-3, *Information technology — Automatic identification and data capture (AIDC) techniques — Harmonized vocabulary — Part 3: Radio frequency identification (RFID)¹⁾*

3 Terms, definitions and abbreviated terms

iTech STANDARD PREVIEW
(standards.iteh.ai)

3.1 Terms and definitions

For the purposes of this document, the terms and definitions given in ISO/IEC 19762-1, ISO/IEC 19762-3 and the following apply.

ISO/IEC 15962:2004
<https://standards.iteh.ai/catalog/standards/sist/0c97ea38-0c08-4c93-bb14-5af8b6352bfc/iso-iec-15962-2004>

NOTE For terms defined below and in ISO/IEC 19762-1 or ISO/IEC 19762-3, the definitions given below apply.

3.1.1 Application commands

The instruction issued from the application to the Data Protocol Processor in order to initiate an action or operation with the RF tag(s) via the interrogator.

3.1.2 Application memory

The area of the RF tag available for storing data written to it. Sometimes known as *user memory*.

3.1.3 Arc

A specific branch of an object identifier tree, with new arcs added as required to define a particular object. The top three arcs of all object identifiers compliant with ISO/IEC 9834-1 are defined in Annex A of ISO/IEC 15961.

3.1.4 Block

The minimum number of bytes on an RF tag that can be in a write transaction, or read transaction, across the air interface.

3.1.5 Command / Response Unit

That part of the Data Protocol Processor that processes application commands and sends responses to control encoding, decoding, structuring of the Logical Memory and transfer to the Tag Driver.

1) To be published.

3.1.6 Data compaction

A mechanism, or algorithm, to process the original data so that it is represented efficiently in fewer bytes in a data carrier than in the original presentation.

3.1.7 Data Compactor

The implementation of the data compaction process defined in this International Standard.

3.1.8 Data Protocol Processor

The implementation of the processes defined in this International Standard, including the Data Compactor, Formatter, Logical Memory, and Command/Response Unit.

3.1.9 elementName

A component of a ReferenceType or enumerated list in ASN.1 Syntax.

3.1.10 Formatter

The implementation of the data formatting process defined in this International Standard.

3.1.11 Logical Memory

A software analogue on the Data Protocol Processor of the Logical Memory Map.

3.1.12 Logical Memory Map

An array of contiguous bytes of memory on the RF tag, representing the application (or user) memory to be used exclusively for the encoding of objects, objectIds, and their associated Precursor on the RF tag. The system information shall be defined by different means or stored in a separate area on the RF tag. This can be achieved by partitioning memory, partly for system information and mainly for the Logical Memory Map purpose.

3.1.13 Object

A well-defined piece of information, definition, or specification which requires a name in order to identify its use in an instance of communication.

3.1.14 Object identifier

A value (distinguishable from all other such values) which is associated with an object.

3.1.15 OBJECT IDENTIFIER type

A simple ASN.1 type whose distinguished values are the set of all object identifiers allocated in accordance with the rules of ISO/IEC 8824-1 (ITU-T X.680).

3.1.16 Precursor

A byte, sometimes a sequence of bytes, within the encodation on the Logical Memory and Logical Memory Map that acts as metadata for the subsequent objectId and object.

3.1.17 RELATIVE-OID type

A particular object identifier where a common root-OID (for the first and subsequent arcs) is implied, and remaining arcs after the root-OID are defined by the RELATIVE-OID.

3.1.18 Response

The feedback received by the application from an application command sent to the Data Protocol Processor.

3.1.19 root-OID

That part of a set of OBJECT IDENTIFIERS that has a common first, second, and subsequent arcs. The root-OID is a prefix to a RELATIVE-OID to construct a complete OBJECT IDENTIFIER.

3.1.20 Tag Driver

The implementation of the process to transfer data between the Data Protocol Processor and the RF tag.

3.1.21 Transfer syntax

The abstract syntax and concrete syntax used in the transfer of data between open systems.

NOTE: The term "transfer syntax" is sometimes used to mean encoding rules, and sometimes used to mean the representation of bits in data while in transit.

3.2 Abbreviated terms

- BER Basic Encoding Rules (of ASN.1)
- EAN.UCC EAN International & Uniform Code Council, Inc
- IATA International Air Transport Association
- UPU Universal Postal Union

4 Protocol model

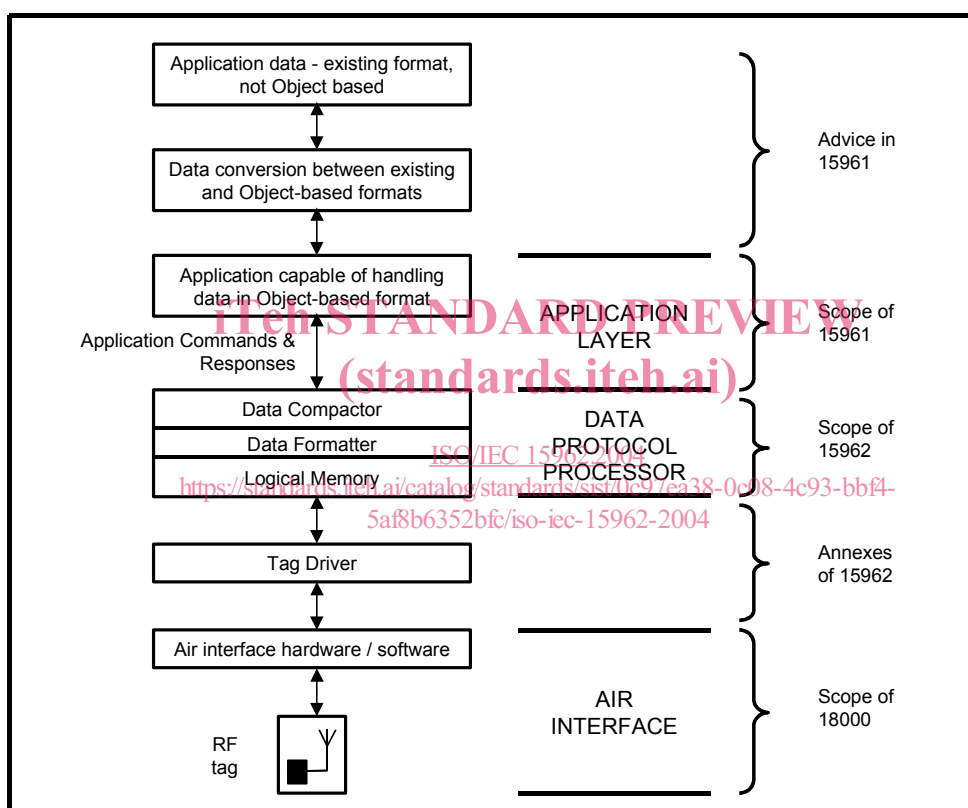

Figure 1 — Schematic of Protocol Layers for an Implementation of RFID for Item Management

4.1 Overview

RFID supports bit encodation in the RF tag memory. Unlike other data carrier standards prepared by ISO/IEC JTC1 SC31 which require encodation schemes that are specific to the individual data carrier technology, ISO/IEC 18000 does not specify the interpretation of bits or bytes encoded on the RF tag memory. However, as an RF tag is a relay in a communication system, each tag used for open systems item management needs to have data encoded in a consistent manner. The prime function of ISO/IEC 15961 is to specify a common interface between the application programs and the RF interrogator. The prime function of this International Standard is to specify the common encoding rules and logical memory functions.

RF tags utilise electronic memory that is typically capable of increasing data capacity as new generations of product are introduced. Differences in data capacity of each RF tag type, whether similar or dissimilar, are recognised by the data protocol defined in these two International Standards.

Different application standards may have their own particular data sets or data dictionaries. Each major application standard for item management needs to have its data treated in an unambiguous manner, avoiding confusion with data from other applications and even with data from closed systems. The data protocol specified in these International Standards ensures the unambiguous identification of data.

4.2 Layered protocol

The protocol layers of an implementation of RFID for item management are illustrated schematically in Figure 1.

The data protocol specified in this International Standard is independent of the different RF tag technologies specified in ISO/IEC 18000, which is concerned with different air interface protocols that function between the interrogator and the RF tag. This independence is achieved by implementing the standards at different levels in the protocol hierarchy. The RFID data protocol defined in this International Standard is primarily concerned with the upper layers as described below:

Application layer - as defined in ISO/IEC 15961

- The RFID data protocol specifies how data is presented as objects, each uniquely identified with an object identifier, which are meaningful to the application and can be encoded on the RF tag.
- This RFID data protocol defines application commands and responses so that application programs can specify what data to transfer to and from the RF tag and to append, update or delete data on the RF tag.
- This RFID data protocol also defines error messages as responses to the application.

The application interface of this RFID data protocol is based on ASN.1, which:

- provides a means of defining the protocol which is independent of the host application, operating system, and programming language and also independent of the specific command structures between the interrogator and tag driver.
- identifies any data object distinctly from all others using object identifiers, even to enable different data formats to be intermixed on the same RF tag.
- defines unambiguous commands and responses, so that they can be intermixed with data on the same wired or wireless network.
- provides the abstract syntax for defining the commands and responses in a structured and consistent and verifiable manner, and provides the transfer syntax that defines the byte stream transferred between the processes of ISO/IEC 15961 and those of this International Standard.
- enables implementation in a variety of computer languages through the use of compilers, alternatively programs can be written from the specification. In either case there is a vital need for the transfer syntax to be fully consistent and compliant to function in open systems where the sender and recipient can be unknown to one another.

Data Protocol Processing - as defined in this International Standard

- The RFID data protocol specifies how data is encoded, compacted and formatted on the RF tag and how this data is retrieved from the RF tag to be meaningful to the application.
- This RFID data protocol provides for a set of schemes that compact the data to make more use of the memory space.
- This RFID data protocol also supports various storage formats to enable efficient use of memory and efficient access procedures.

All these features are described and specified later in this International Standard and its companion standard. Figure 1, and the outline description above, applies to a general process. Different rules may apply to RF tags that are capable of executing commands (see 7.3.3).

This RFID data protocol specifies the application level communication and the RF tag interrogator level rules for data encoding, compaction and storage formats. This protocol may be implemented:

- on the same platform as the application.
- on a separate platform linked to the application platform e.g. linked via a serial link, LAN or internet connection.
- on an embedded platform e.g. in a bar code printer/RFID encoder, in a bar code/RFID scanner, or a dedicated RFID interrogator.

This RFID data protocol has been designed such that the actual platform on which it is implemented is transparent to the application. It is also independent of the programming language used by the application. If both standards are not implemented, care will need to be taken to maintain the functionality between the two standards. The compliance clauses of both standards address these points in greater detail.

The rules specified in these International Standards create a complete independence between the application and the technology of the air interface and RF tag. The type of RF tag used in an implementation can be changed without requiring the application to change.

4.3 Functional processes

iTeh STANDARD PREVIEW

There are various functional processes that need to take place to write data to an RF tag and to read data from it. Figure 2 shows a schematic of an implementation where the processing of the data protocol resides in the interrogator. This illustration is provided to help with the understanding of the processes, and although a typical implementation, many others are possibly compliant with this data protocol.

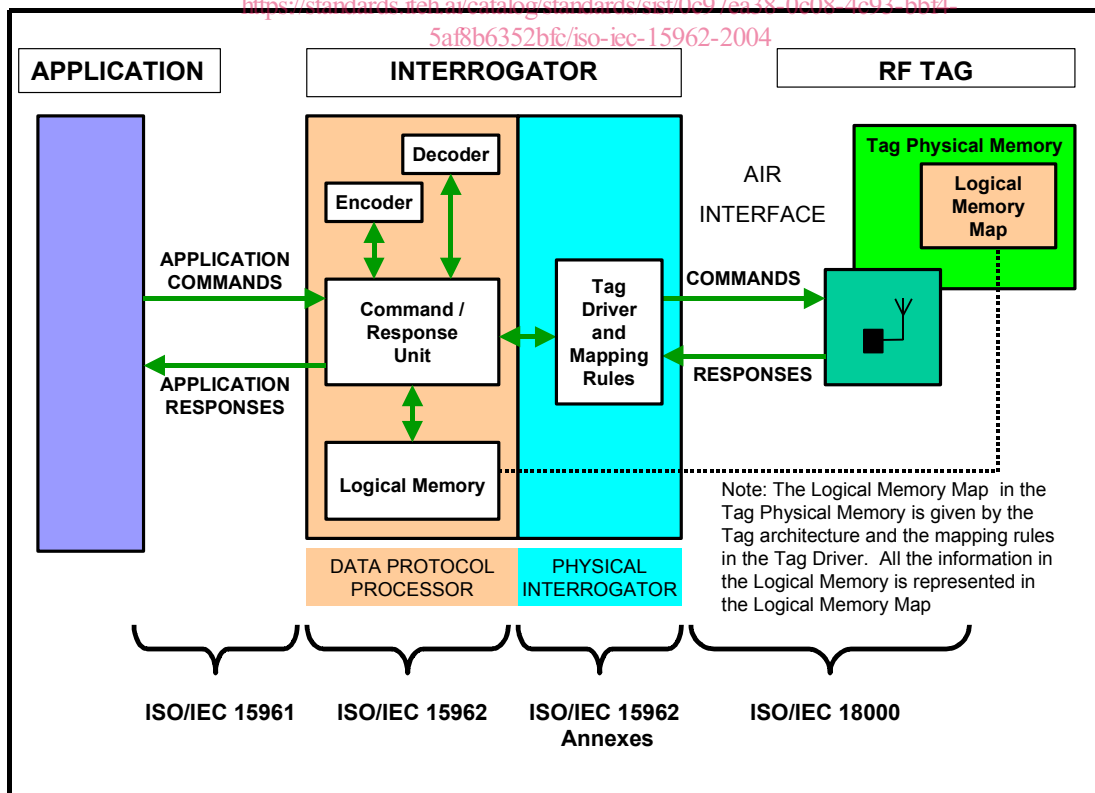

Figure 2 — Logical Functions and Interfaces

Application is the user application database and software.

The data flows between the application and the Data Protocol Processor are formatted according to ISO/IEC 15961 and are uncompact. However, there are numerous established systems where data is formatted to be compliant, for example, with a bar code related syntax. It is therefore reasonable to insert interface modules in the data flow to convert from and to existing application formats.

NOTE: Careful consideration should be given to the extent that established systems need to be supported relative to the potential benefits to be gained from adopting the data protocol specified in ISO/IEC 15961 and this International Standard. This is because this protocol has been developed around the features of RFID, such as selective read/write and the ability to lock data. Older protocols are unlikely to support such features.

Interrogator is the module in which all the basic processing of the data protocol takes place and there is an interface to the RF tag.

Data Protocol Processor provides all the processing, which is as specified in this International Standard and is required for handling application data. It consists of the following components, all of which are described more fully below: Command/Response Unit, Logical Memory, Encoder (which supports a Data Compactor and Formatter function) and Decoder (which supports the inverse functions of the Encoder). The Data Protocol Processor can physically reside anywhere between the application software and the tag driver but shall contain all the components.

Command/Response Unit for receiving the application commands from the application in a format specified in ISO/IEC 15961, acting upon these commands where appropriate and converting to the specific RF tag lower level command codes.

EXAMPLE:

(standards.iteh.ai)

An application command of *write Data Object {name}* is application related. The data protocol recognises this and can format the data onto the Logical Memory in the Data Protocol Processor. The information from the particular RF tag is required to set the parameters of the Logical Memory Map (e.g. number of octets, whether a directory is in use, etc) on the RF Tag. The Tag Driver converts the application command into a tag-specific command.

It can be seen from this example that there is a distinct boundary between the Data Protocol Processor and the Tag Driver.

Logical Memory. This is an array of contiguous octets (or bytes) of memory acting as a common representation of the Logical Memory Map in the user memory of the RF tag to which the object identifiers and data objects are mapped in octets. The Logical Memory takes into account some parameters of the real RF tag, for example the block size, the number of blocks and the storage format. The Logical Memory ignores any detailed tag architecture.

The use of the Logical Memory means that an application can interface with an application-compliant RF tag, but that individual RF tags can have completely different memory capacities and architectures. This enables an implementation to benefit from new technological developments permitted within the framework of ISO/IEC 18000, such as larger capacity or faster access RF tags, without changing the application.

Encoder controls the process of writing data through the functional processes performed by the Data Compactor Module and Formatter Module.

Data Compactor provides the standard compaction rules to reduce the number of octets stored on the RF tag and transferred across the air interface. Numeric data, for example, is octet based to some coded character set for the application, but can be encoded in a compact form on the RF tag memory.

Formatter provides the processes to place the object identifier and object (data) into an appropriate and efficient format for storing on the Logical Memory.