



Designation: D 5154 – 03

## Standard Test Method for Determining Activity and Selectivity of Fluid Catalytic Cracking (FCC) Catalysts by Microactivity Test<sup>1</sup>

This standard is issued under the fixed designation D 5154; the number immediately following the designation indicates the year of original adoption or, in the case of revision, the year of last revision. A number in parentheses indicates the year of last reapproval. A superscript epsilon ( $\epsilon$ ) indicates an editorial change since the last revision or reapproval.

### 1. Scope

1.1 This test method covers determining the activity and selectivity of either equilibrium or laboratory deactivated fluid catalytic cracking (FCC) catalysts. The activity is evaluated on the basis of weight percent conversion of gas oil in a microactivity unit. The selectivities are evaluated on the basis of weight percent yields of specifically defined products resulting from the catalytic cracking of gas oil.

1.2 The values stated in SI units are to be regarded as standard. The values given in parentheses are provided for information only.

1.3 *This standard does not purport to address all of the safety concerns, if any, associated with its use. It is the responsibility of the user of this standard to establish appropriate safety and health practices and determine the applicability of regulatory limitations prior to use.*

### 2. Referenced Documents

#### 2.1 ASTM Standards:<sup>2</sup>

- D 2887 Test Method for Boiling Range Distribution of Petroleum Fractions by Gas Chromatography
- D 3907 Test Method for Testing Fluid Catalytic Cracking (FCC) Catalysts by Microactivity Test
- D 4463 Guide for Metals Free Steam Deactivation of Fresh Fluid Catalytic Cracking Catalysts
- E 105 Practice for Probability Sampling of Materials
- E 177 Practice for Use of the Terms Precision and Bias in ASTM Test Methods
- E 456 Terminology Relating to Quality and Statistics
- E 691 Practice for Conducting an Interlaboratory Study to Determine the Precision of a Test Method

### 3. Terminology

#### 3.1 Definitions of Terms Specific to This Standard:

<sup>1</sup> This test method is under the jurisdiction of ASTM Committee D32 on Catalysts and is the direct responsibility of Subcommittee D32.04 on Catalytic Properties.

Current edition approved Oct. 1, 2003. Published October 2003. Originally approved in 1991. Discontinued in 2000 and reinstated as D 5154–03. Last previous edition approved as D 5154–99.

<sup>2</sup> For referenced ASTM standards, visit the ASTM website, www.astm.org, or contact ASTM Customer Service at service@astm.org. For *Annual Book of ASTM Standards* volume information, refer to the standard's Document Summary page on the ASTM website.

3.1.1 *activity*—calculated as conversion divided by the difference of 100 minus conversion.

3.1.2 *ASTM reference catalysts*—a set of equilibrium FCC catalysts within the useful range of this test method is used to improve the reproducibility of test results between different laboratories. Each catalyst has a consensus mean conversion value assigned to it by Committee D32. Samples of the ASTM reference catalysts can be obtained through NIST.

3.1.3 *ASTM standard feed*—a specific batch of gas oil that is used as feedstock in the described test method.<sup>3</sup>

3.1.4 *catalyst/oil (C/O) ratio*—the weight of catalyst used in the test divided by the weight of feed fed to the reactor. In practice, the weight of catalyst is usually maintained at a constant value and the total weight of feed is varied.

3.1.5 *contact time*—calculated as  $3600/(\text{WHSV} \cdot \text{C/O})$ . This is the delivery time, in seconds, during which feed is introduced to the reactor.

3.1.6 *HCO*—the heavy cycle oil product defined to have a minimum boiling point of 343°C (650°F).

3.1.7 *LCO*—the light cycle oil product defined to have a boiling point range of 216 to 343°C (421 to 650°F).

3.1.8 *measured conversion*—calculated as the difference between the weight of feed used and the weight of unconverted material divided by the weight of feed used times 100 %. The unconverted material is defined as all liquid product with a boiling point above 216°C (42°F).

3.1.9 *normalized product yield*—the result obtained when each product yield has been corrected for non-perfect weight balances. For a run to be judged acceptable, the total recovery, wt % of feed, should be in the range of 96 to 101 % prior to normalization. If the recovery is outside this range the test data should be discarded.

3.1.10 *product yield*—one hundred times the weight of a specific product divided by the weight of feed used in the test.

3.1.11 *reaction severity*—an indication of the severity of the cracking reaction which allows a range of conversions to be obtained from any particular catalyst without changing reactor temperature. Changing reaction severity is achieved by changing WHSV or C/O ratio or both.

<sup>3</sup> Available from National Institute of Standards and Technology (NIST), 100 Bureau Dr., Stop 3460, Gaithersburg, MD 20899-3460.

3.1.12 *weight hourly space velocity (WHSV)*—the oil feed rate in grams per hour divided by the weight of catalyst in grams. Units are  $\text{hr}^{-1}$ .

#### 4. Summary of Test Method

4.1 At least two samples of FCC catalysts, one of which is chosen as a reference, are separately contacted with gas oil (ASTM Standard Feed or other suitable feedstock) in a fixed bed reactor at a specified reaction temperature and at more than one reaction severity. Reaction products (liquid, gas, and coke on catalyst) are analyzed. Conversion, activity, and product yields are calculated for each experiment.

4.2 Following analysis of the products, the total recovery (that is, weight balance) of the feed as converted and unconverted products is determined. If the recovery is less than 96 % or greater than 101 %, the test is rejected as unsatisfactory.

4.3 For each catalyst tested, normalized product yields are plotted against conversion or activity to generate a yield curve. The data comprising the yield curve may be used to obtain the parameters of an appropriate mathematical expression for the curve. Comparisons among catalysts can be made by interpolating the yield curves to obtain the product yields at some specified conversion.

#### 5. Significance and Use

5.1 The microactivity test provides data to assess the relative performance of FCC catalysts. Because results are affected by catalyst pretreatment, feedstock characteristics, test equipment, and operating parameters, adherence to this test method is a prerequisite for correct interpretation of results. Apparatus, test conditions, and analytical procedures actually used should closely resemble those described in this test method. Significant variations in apparatus, test conditions and/or analytical procedures may result in activity and selectivity data which do not correlate with data developed by other laboratories on identical catalyst/feedstock samples.

5.2 The standard method reaction temperature is  $516^{\circ}\text{C}$  ( $960^{\circ}\text{F}$ ). Other reaction temperatures can be used; however, catalyst selectivity data developed at temperatures other than  $516^{\circ}\text{C}$  may not correlate with selectivity data developed at  $516^{\circ}\text{C}$ . Also, precision at other reaction temperatures may change compared to data obtained at  $516^{\circ}\text{C}$ .

#### 6. Apparatus

6.1 The apparatus of this test method is essentially that described in Test Method D 3907, as shown in Figs. 1-4, with the addition of a gas collection system on the effluent gas vent line. In a typical gas collection system, a fluid is displaced by the collected gas and the volume of displaced liquid provides a quantitative measurement of the amount of gas collected. To minimize the solubility of gases like  $\text{H}_2$  and  $\text{H}_2\text{S}$  in the fluid, a saturated brine ( $\text{NaCl}$ ) solution is recommended. Some publications have appeared which give example flow schematics and more detailed descriptions of typical apparatus.<sup>4</sup> Alternatively, there are several vendors as listed in Research

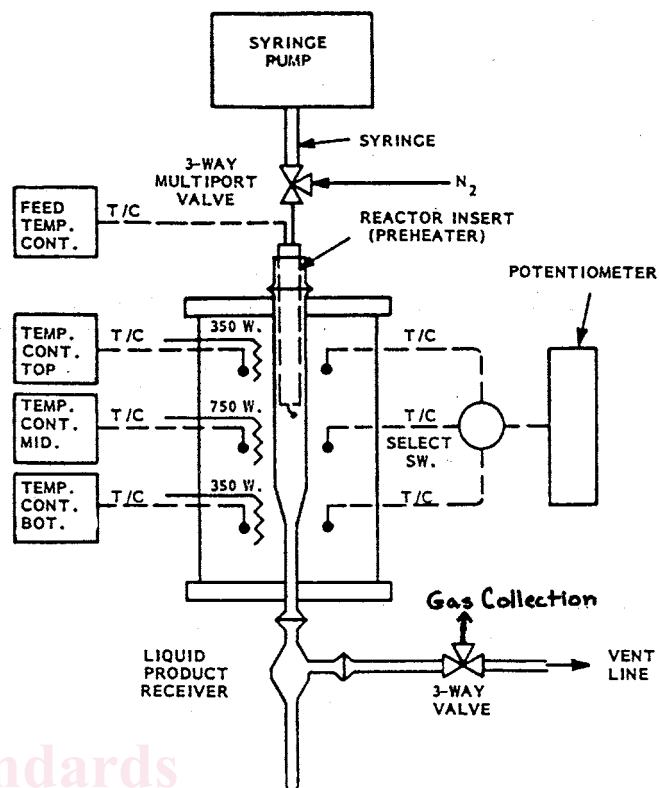

NOTE—This drawing is not to scale. For engineering details, see other drawings.

FIG. 1 Microactivity Flow Chart

Report RR: D32-1030<sup>5</sup> who can provide specific equipment for performing this test. However, Committee D32 can only suggest and will not recommend nor certify any specific vendor. Significant variations from the test apparatus of this method most likely will result in significantly different activity and selectivity data from identical catalyst samples.

#### 6.2 Chromatographic Equipment:

6.2.1 Liquid product analyses should be performed using Test Method D 2887 on a gas chromatograph (G.C.) equipped with a flame ionization detector.

6.2.2 Gas product analyses may be accomplished in two parts. First, an analysis using a G.C. equipped with a thermal conductivity detector, employing  $\text{N}_2$  as a carrier gas, and using a G.C. column that permits the separation and quantitative identification of  $\text{H}_2$  and  $\text{H}_2\text{S}$ . Second, an analysis using a G.C. equipped with a FID or TCD, employing  $\text{He}$  as a carrier gas and using a column that permits the separation and quantitative identification of methane, ethane, ethylene, propane, propylene, n-butane, iso-butane, 1-butene and iso-butene, cis-2-butene, and trans-2-butene,  $\text{C}_5$ 's and a  $\text{C}_5^+$  lump that is not resolved. The  $\text{C}_5$ 's and the  $\text{C}_5^+$  group are included as part of the gasoline fraction.

<sup>4</sup> Campagna, R. J., Wick, J. P., Brady, M. F., and Fort, D. L., "Fresh FCC Catalyst Tests Predict Performance," *OGJ*, March 24, 1986, p. 85.

<sup>5</sup> Supporting data have been filed at ASTM International Headquarters and may be obtained by requesting Research Report RR: D32-1030.

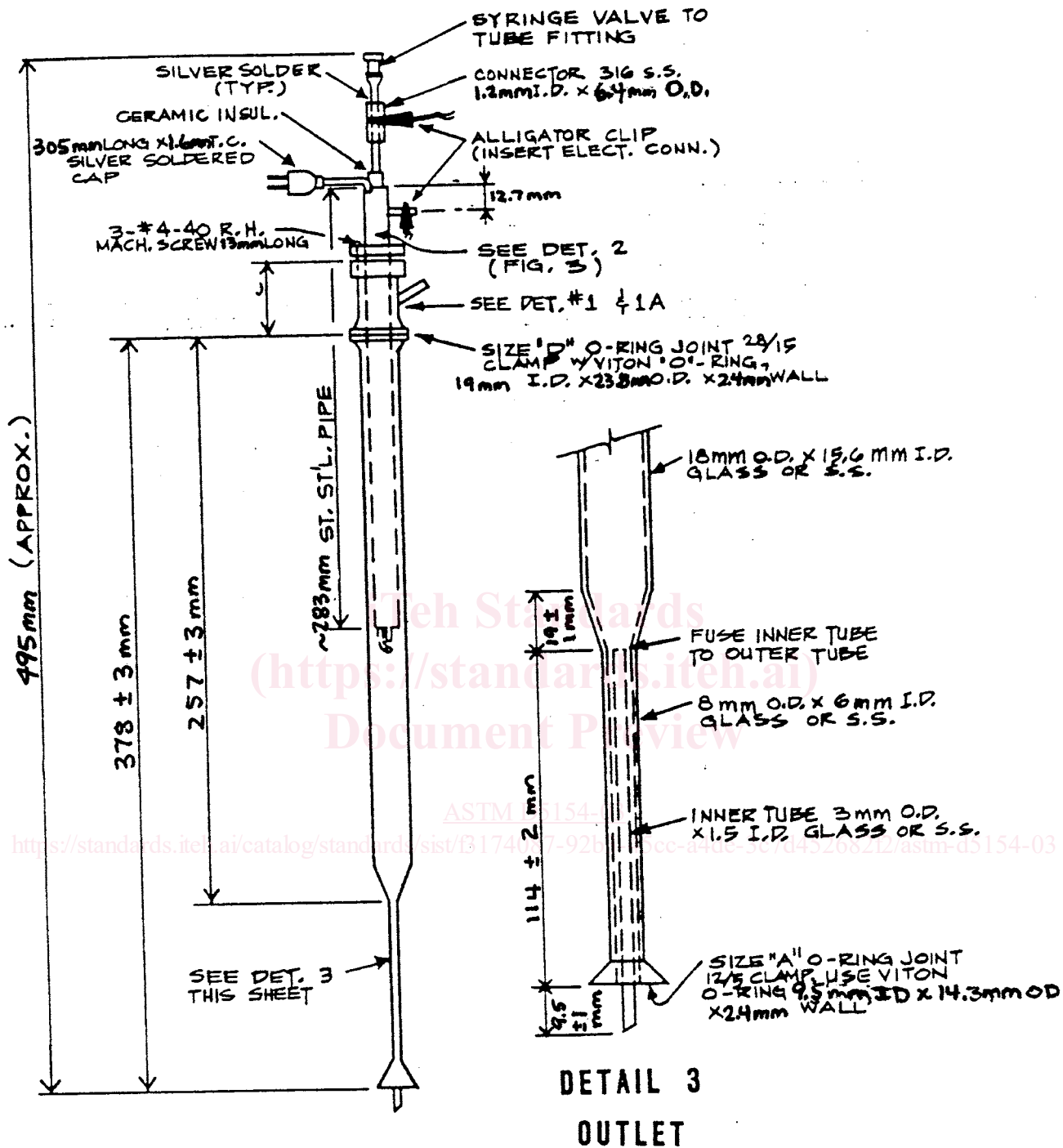

FIG. 2 Microactivity Reactor

6.3 Carbon analysis of a representative sample of the spent catalyst (that is, after the cracking reaction has been completed) may be accomplished using a commercially available carbon analyzer.

**7. Sampling**

7.1 A. sampling procedure is needed. Practice E 105 is appropriate.

**8. Sample Preparation**

8.1 *Equilibrium Catalysts*—Dry samples or decoke, or both, by heating a shallow (less than 10 mm thick) bed of catalyst in a porcelain crucible at 590 ± 20°C (1094 ± 36°F) for a length of time sufficient to remove any coke. This typically requires approximately three hours. Sufficient air should be available in the furnace to burn the sample free of coke. Insufficient decoking is indicated by a difference in color of the top and

3.1mm D.A. DRILL - 3  
EQ. SPA. ON 24mm DIA.

2.4mm DRILL, TAP # 4-40,  
3 EQ. SPA. ON 24mm DIA.

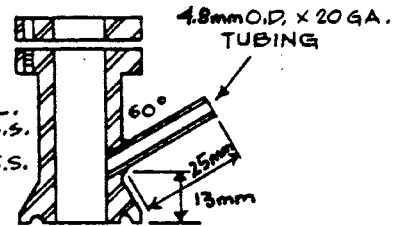
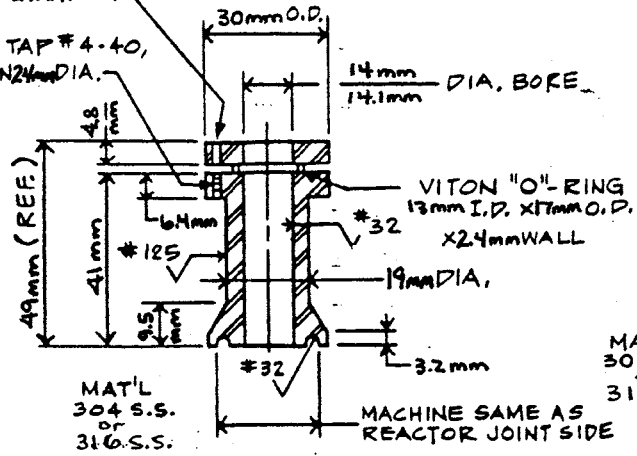

DETAIL 1

DETAIL 1A

WITH SIDE ARM FOR PRESS.  
MEASUREMENT DURING RUN

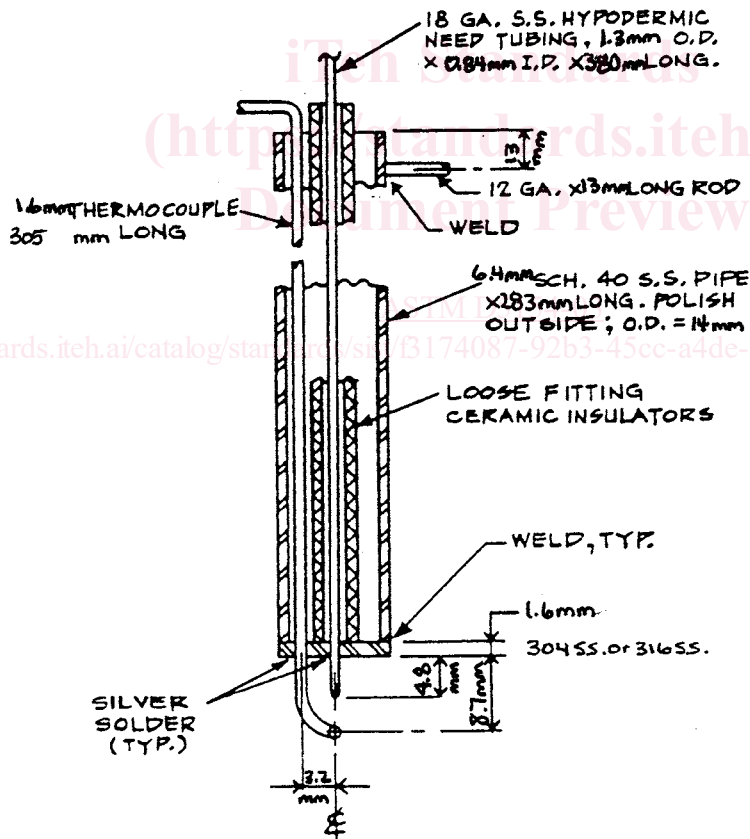

DETAIL 2

FIG. 3 Reactor Feed Tube Insert