Aerospace — Rivets, solid — Test method

Aéronautique et espace — Rivets ordinaires — Méthode de contrôle et d'essai

iTeh STANDARD PREVIEW
(standards.iteh.ai)

[ISO 17057:1999](https://standards.iteh.ai/catalog/standards/sist/658f075e-0d64-4c7d-84da-b88406db5cd5/iso-17057-1999)

<https://standards.iteh.ai/catalog/standards/sist/658f075e-0d64-4c7d-84da-b88406db5cd5/iso-17057-1999>



PDF disclaimer

This PDF file may contain embedded typefaces. In accordance with Adobe's licensing policy, this file may be printed or viewed but shall not be edited unless the typefaces which are embedded are licensed to and installed on the computer performing the editing. In downloading this file, parties accept therein the responsibility of not infringing Adobe's licensing policy. The ISO Central Secretariat accepts no liability in this area.

Adobe is a trademark of Adobe Systems Incorporated.

Details of the software products used to create this PDF file can be found in the General Info relative to the file; the PDF-creation parameters were optimized for printing. Every care has been taken to ensure that the file is suitable for use by ISO member bodies. In the unlikely event that a problem relating to it is found, please inform the Central Secretariat at the address given below.

iTeh STANDARD PREVIEW
(standards.iteh.ai)

ISO 17057:1999

<https://standards.iteh.ai/catalog/standards/sist/658f075e-0d64-4c7d-84da-b88406db5cd5/iso-17057-1999>

© ISO 1999

All rights reserved. Unless otherwise specified, no part of this publication may be reproduced or utilized in any form or by any means, electronic or mechanical, including photocopying and microfilm, without permission in writing from either ISO at the address below or ISO's member body in the country of the requester.

ISO copyright office
Case postale 56 • CH-1211 Geneva 20
Tel. + 41 22 749 01 11
Fax + 41 22 734 10 79
E-mail copyright@iso.ch
Web www.iso.ch

Printed in Switzerland

Foreword

ISO (the International Organization for Standardization) is a worldwide federation of national standards bodies (ISO member bodies). The work of preparing International Standards is normally carried out through ISO technical committees. Each member body interested in a subject for which a technical committee has been established has the right to be represented on that committee. International organizations, governmental and non-governmental, in liaison with ISO, also take part in the work. ISO collaborates closely with the International Electrotechnical Commission (IEC) on all matters of electrotechnical standardization.

International Standards are drafted in accordance with the rules given in the ISO/IEC Directives, Part 3.

Draft International Standards adopted by the technical committees are circulated to the member bodies for voting. Publication as an International Standard requires approval by at least 75 % of the member bodies casting a vote.

Attention is drawn to the possibility that some of the elements of this International Standard may be the subject of patent rights. ISO shall not be held responsible for identifying any or all such patent rights.

International Standard ISO 17057 was prepared by Technical Committee ISO/TC 20, *Aircraft and space vehicles*, Subcommittee SC 4, *Aerospace fastener systems*.

Annex A forms a normative part of this International Standard.

ITEH STANDARD PREVIEW
(standards.iteh.ai)

[ISO 17057:1999](https://standards.iteh.ai/catalog/standards/sist/658f075e-0d64-4c7d-84da-b88406db5cd5/iso-17057-1999)

<https://standards.iteh.ai/catalog/standards/sist/658f075e-0d64-4c7d-84da-b88406db5cd5/iso-17057-1999>

Aerospace — Rivets, solid — Test method

1 Scope

This International Standard specifies the test method for solid rivets. It describes the test device and the method.

It applies to rivets intended for use in aerospace construction in conjunction with the relevant procurement specification, provided that the specification refers to this International Standard.

2 Normative reference

The following normative document contains provisions which, through reference in this text, constitute provisions of this International Standard. For dated references, subsequent amendments to, or revisions of, any of these publications do not apply. However, parties to agreements based on this International Standard are encouraged to investigate the possibility of applying the most recent edition of the normative document indicated below. For undated references, the latest edition of the normative document referred to applies. Members of ISO and IEC maintain registers of currently valid International Standards.

ISO 7500-1:1999, *Metallic materials — Verification of static uniaxial testing machines — Part 1: Tension/compression testing machines — Verification and calibration of the force-measuring system.*

[ISO 17057:1999](https://standards.iteh.ai/catalog/standards/sist/658f075e-0d64-4c7d-84da-b88406db5cd5/iso-17057-1999)

<https://standards.iteh.ai/catalog/standards/sist/658f075e-0d64-4c7d-84da-b88406db5cd5/iso-17057-1999>

3 Double shear inspection and test

3.1 Apparatus

3.1.1 Testing machine, the accuracy of which shall be verified to the requirements of ISO 7500-1:1999, with class of testing machine range 1,0.

The test machine shall be calibrated as specified in annex A.

3.1.2 Test fixture, made of steel with a minimum hardness of 530 HV 30. The dimensions of the fixture shall be in conformity with those in Figure 1.

To minimize the possible effect of distortion of the fixture under load, fitted machined steel bolts shall be used.

The interfaces between the middle part and the leg part shall be well polished.

3.2 Procedure

3.2.1 Place the rivet or riveting wire in the test fixture so that contact is made with the full bearing surface.

3.2.2 Record the maximum load F to fracture.

Shear strength is:

$$R_s = 0,5 \frac{F}{\pi \left(\frac{d_a^2}{4} \right)} = \frac{2F}{\pi d_a^2}$$

where d_a is the actual diameter of the specimen at the shear zone.

3.2.3 The speed of testing shall be less than or equal to 20 mm/min (0,75 in/min).

3.2.4 The test may be discontinued without a complete shear failure once the required minimum ultimate test load has been achieved.

iTeh STANDARD PREVIEW
(standards.iteh.ai)

ISO 17057:1999

<https://standards.iteh.ai/catalog/standards/sist/658f075e-0d64-4c7d-84da-b88406db5cd5/iso-17057-1999>

Dimensions in millimetres
(Dimensions in inches in parentheses)

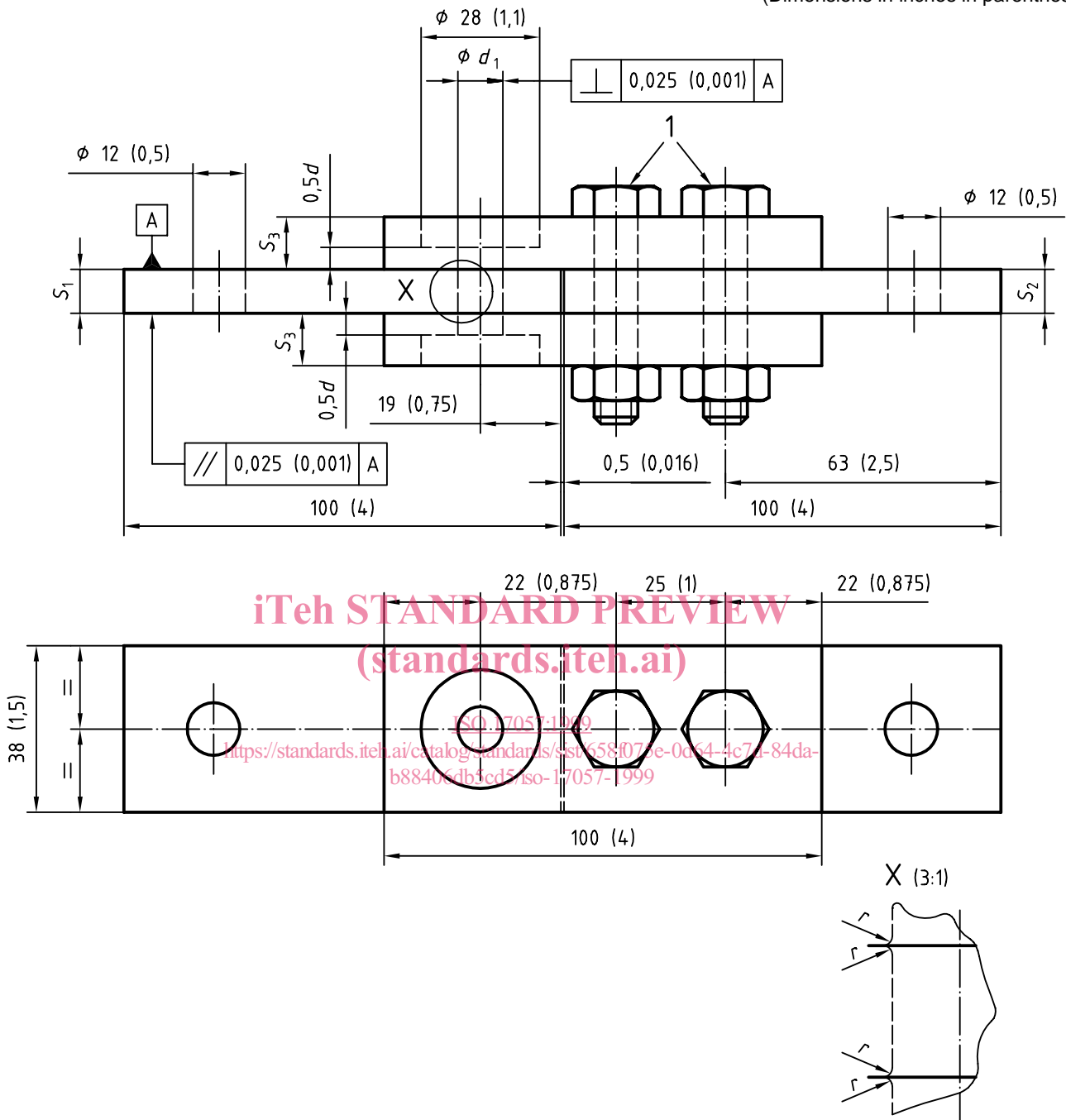

d is the nominal diameter of wire or rivet
 r is the resulting radius subsequent to wear of the edges of the diameter d_1 hole
 $d_1 = 1,020 d + 0,075 \text{ mm} \pm 0,015 \text{ mm}$ (0,003 in \pm 0,000 6 in)
 $r \leq 0,13 \text{ mm}$ (0,005 in)
 $S_1 = d - \overset{0}{-0,3 \text{ mm}}$ ($\overset{0}{-0,012 \text{ in}}$)

$S_2 = S_1 \pm 0,025 \text{ mm} \overset{+0,03 \text{ mm}}{0}$ ($0,001 \text{ in} \overset{+0,0012 \text{ in}}{0}$)
 $S_3 = 6 \text{ mm} \pm 0,4 \text{ mm}$ (0,25 in \pm 0,016 in) for
 $d = 1,5 \text{ mm}$ (0,063 in) to 4 mm (0,156 in)
 $12 \text{ mm} \pm 0,4 \text{ mm}$ (0,5 in \pm 0,016 in) for
 $d = 5 \text{ mm}$ (0,188 in) to 10 mm (0,375 in)
Tolerances on $0,5d$: $\overset{+0,03 \text{ mm}}{0}$ ($\overset{+0,0012 \text{ in}}{0}$)

Key

- 1 Fitted M10 (0,375) steel bolts

Figure 1

Annex A
(normative)

Calibration of test apparatus

Test apparatus in use shall be calibrated periodically at intervals not exceeding 12 months by one of the following means:

- a) a national official body;
- b) an organization controlled by a national official body;
- c) by using standards or devices which are traceable back to a national standards body.

iTeh STANDARD PREVIEW
(standards.iteh.ai)

ISO 17057:1999

<https://standards.iteh.ai/catalog/standards/sist/658f075e-0d64-4c7d-84da-b88406db5cd5/iso-17057-1999>

iTeh STANDARD PREVIEW
(standards.iteh.ai)

ISO 17057:1999

<https://standards.iteh.ai/catalog/standards/sist/658f075e-0d64-4c7d-84da-b88406db5cd5/iso-17057-1999>

ICS 49.030.60

Price based on 4 pages