



# Standard Test Method for Pressure-Sensitive Adhesive-Coated Tapes Used for Electrical and Electronic Applications<sup>1</sup>

This standard is issued under the fixed designation D 1000; the number immediately following the designation indicates the year of original adoption or, in the case of revision, the year of last revision. A number in parentheses indicates the year of last reapproval. A superscript epsilon ( $\epsilon$ ) indicates an editorial change since the last revision or reapproval.

*This standard has been approved for use by agencies of the Department of Defense.*

## 1. Scope

1.1 These test methods cover procedures for testing pressure-sensitive adhesive-coated tapes to be used as electrical insulation. These tapes are classified as follows:

1.1.1 *Class 1*—Non-elastomeric backings made from materials such as:

- Paper, flat or creped,
- Fabric, uncoated or coated,
- Cellulose ester films,
- Polyethylene terephthalate (polyester) films,
- Fluorocarbon polymer films,
- Composite filament films,
- Polyamide films,
- Polyimide films, and
- Combinations thereof.

1.1.2 *Class 2*—Elastomeric backings that are characterized by both high stretch and substantial recovery. These backings are made from materials such as:

- Vinyl chloride and co-polymers,
- Vinylidene chloride and co-polymers, and
- Polyethylene and co-polymers.

1.2 Laminates of Class 1 and Class 2 backings should be tested according to Class 1 test methods.

1.3 *This standard does not purport to address all of the safety concerns, if any, associated with its use. It is the responsibility of the user of this standard to establish appropriate safety and health practices and determine the applicability of regulatory limitations prior to use.* For specific hazards see Section 3.

1.4 The procedures appear in the sections indicated below and in alphabetical order:

Adhesion Strength to Steel and Backing at Room Temperature	46-53
Adhesion Strength to Steel and Backing at Low Temperatures	46-53
Bond Strength After Solvent Immersion	110-115
Breaking Strength and Elongation at Room Temperature	37-45
Breaking Strength and Elongation at Low Temperatures	37-45
Conditioning	6-8
Curling and Twisting	140-146

<sup>1</sup> These test methods are under the jurisdiction of ASTM Committee D-9 on Electrical and Electronic Insulating Materials, and are the direct responsibility of Subcommittee D09.07 on Flexible and Rigid Insulating Materials.

Current edition approved March 10, 1999. Published June 1999. Originally published as D 1000 – 48. Last previous edition D 1000 – 93.

Dielectric Breakdown Voltage	83-90
Effect of Accelerated Aging on High-Temperature Tapes	97-103
Flagging	66-76
Flammability	104-109
Hazards/Precautions	3
Insulation Resistance at High Humidity	91-96
Length of Tape in a Roll	28-36
Oil Resistance	116-122
Puncture Resistance	123-128
Resistance to Accelerated Aging (Heat and Moisture)	129-139
Sampling	4
Specimen Preparation	5
Thermosetting Properties	77-82
Thickness	21-27
Unwind Force at Room Temperature	54-65
Unwind Force at Low Temperatures	54-65
Width	11-20

NOTE 1—These procedures apply to both Class 1 and Class 2 tapes except as noted above.

1.5 The values stated in SI units are the standard, unless otherwise noted. If a value for measurement is followed by a value in inch-pound or English units in parentheses, the second value may only be approximate and is for information only. The first stated value is the preferred unit.

NOTE 2—These test methods are similar to IEC 60454-3, but may differ sometimes in some details.

1.6 This is a fire-test response standard.

## 2. Referenced Documents

### 2.1 ASTM Standards:

- A 167 Specification for Stainless and Heat-Resisting Chromium-Nickel Steel Plate, Sheet, and Strip<sup>2</sup>
- D 149 Test Method for Dielectric Breakdown Voltage and Dielectric Strength of Solid Electrical Insulating Materials at Commercial Power Frequencies<sup>3</sup>
- D 257 Test Methods for DC Resistance or Conductance of Insulating Materials<sup>3</sup>
- D 295 Test Methods for Varnished Cotton Fabrics Used for Electrical Insulation<sup>3</sup>
- D 374 Test Methods for Thickness of Solid Electrical Insulation<sup>3</sup>

<sup>2</sup> Annual Book of ASTM Standards, Vol 01.03.

<sup>3</sup> Annual Book of ASTM Standards, Vol 10.01.

- D 1711 Terminology Relating to Electrical Insulation<sup>3</sup>
- D 3487 Specification for Mineral Insulating Oil Used in Electrical Apparatus<sup>4</sup>
- D 5032 Practice for Maintaining Constant Relative Humidity by Means of Aqueous Glycerin Solutions<sup>5</sup>
- E 691 Practice for Conducting an Interlaboratory Study to Determine the Precision of a Test Method<sup>6</sup>
- 2.2 IEC Standard:
- IEC 60454-3 Specification for Pressure-Sensitive Adhesive Tapes for Electrical Purposes<sup>7</sup>

### 3. Hazards

3.1 The following specific substances are flammable liquids. Do not use them in the vicinity of open flames or electrical contacts: *acetone* (see 50.1 and 94.1), *heptane* (see 50.1 and 94.1), and *toluene* (see 70.6). They must be stored in closed containers, and it is imperative to clean apparatus in a well-ventilated area.

3.2 As a toxic substance, toluene should be used only where adequate ventilation is provided and in such manner as to avoid any absorption through the skin (see 70.6).

3.3 **Warning**— *Lethal voltages may be present during test methods which evaluate electrical properties. It is essential that the test apparatus, and all associated equipment that may be electrically connected to it, be properly designed and installed for safe operation. Solidly ground all electrically conductive parts that any person might come in contact with during the test. Provide means for use, at the completion of any test, to ground any parts which: were at high voltage during the test; may have acquired an induced charge during the test; may retain a charge even after disconnection of the voltage source. Thoroughly instruct all operators in the proper way to conduct tests safely. When making high voltage tests, particularly in compressed gas or in oil, the energy released at breakdown may be sufficient to result in fire, explosion, or rupture of the test chamber. Design test equipment, test chambers, and test specimens so as to minimize the possibility of such occurrences and to eliminate the possibility of personal injury.*

### SAMPLING

#### 4. Sample and Specimen Requirements

4.1 Unless otherwise specified, select one sample roll for each 10 000 rolls in a lot, with a minimum of three sample rolls per lot.

4.2 For sampling purposes, a lot consists of identifiable materials of the same type, manufactured in one production run and offered for delivery at the same time.

4.3 All test methods in this standard are intended to produce a test value for a single roll. Any reference to averaging of measurements refers to the averaging of measurements on a single roll and not to the average of all sample rolls.

4.4 See Table 1 for a summary of standard requirements for the number of test specimens to select from each sample roll, the number of test measurements to make per test specimen, and the value to be reported.

4.5 Include in every report the complete identification of the tape tested.

### SPECIMEN PREPARATION

#### 5. Test Specimen Preparation

5.1 Place any roll of tape to test on a freely revolving mandrel. Except for determination of length of tape in a roll, remove and discard a minimum of three layers before removing tape for preparation of test specimens.

5.2 Remove sufficient length of tape, at the rate of approximately 50 mm/s (2 in./s), to provide the specimens required for all tests. Cut the tape with a sharp razor blade or scissors, unless otherwise specified. Place the tape on a smooth clean surface, adhesive side up, or suspend it from one end in free air. Protect the adhesive surface from dust. Do not allow the adhesive surface to contact the operator's fingers or other foreign objects. From this tape material, prepare specimens as required in the individual test methods. See also Table 1.

5.3 Use test specimens that are the width of the tape as received, if possible. If it is necessary to prepare narrower specimens as prescribed in the test method, use extreme care since hand trimming may materially affect the test results. Two recommended procedures are (1) to slit the specimen with a sharp razor blade free of nicks while the specimen is held down with a pattern of the desired width, or (2) to slit with mounted parallel sharp razor blades free of nicks to the desired width.

### CONDITIONING

#### 6. Terminology

6.1 Definitions: B-17e11 ffe68a7/astm-d1000-99

**TABLE 1 Testing and Reporting**

Test	Section	Tests per Specimen <sup>A</sup>	Specimens per Roll <sup>A</sup>	Report <sup>B</sup>
Width	14, 19	3	1	avg
Thickness	26	3	1	avg
Length of tape in a roll	35	1	1	value
Breaking strength	44	1	3	avg
Elongation	44	1	3	avg
Adhesion strength	52	1	3	avg
Unwind force				
Fast rate of removal	64	1	1	value
Slow rate of removal	64	3	1	avg
Flagging				
Class 1 Tape	71	3	1	avg
Class 2 Tape	75	1	3	avg
Thermosetting properties	81	1	3	avg
Dielectric breakdown voltage	89	3	3	avg
Insulation resistance at high humidity	95	5	1	med
Effect of accelerated aging	102	3	2	avg
Flammability	108	1	3	avg
Bond strength after solvent immersion	114	1	3	avg
Oil resistance	121	1	4	avg
Puncture resistance	127	1	5	avg
Resistance to accelerated aging	129, 133	1	6	avg
Curling and twisting	140	1	3	avg

<sup>A</sup> When referee testing is involved, use an average of 5 determinations wherever 1 or 3 are specified above.

<sup>B</sup> Minimum and maximum values may also be required when average values are reported.

<sup>4</sup> Annual Book of ASTM Standards, Vol 10.03.

<sup>5</sup> Annual Book of ASTM Standards, Vol 10.02.

<sup>6</sup> Annual Book of ASTM Standards, Vol 14.02.

<sup>7</sup> Available from American National Standards Institute, 11 W. 42<sup>nd</sup> St., New York, NY 10036.

6.1.1 *conditioning, n*—the exposure of a material to the influence of a prescribed atmosphere for a stipulated period of time or until a stipulated relation is reached between material and atmosphere.

## 7. Significance and Use

7.1 The physical and electrical properties such as adhesion, elongation, breaking strength, and dielectric breakdown will vary with temperature and moisture content. Actual service results are influenced by these factors. In order that test methods yield consistent and reproducible results, control the temperature and moisture content of the sample or specimen.

## 8. Conditioning for Room Temperature Measurements

8.1 Condition all rolls of tape for a minimum of 24 h to a temperature of 20 to 25°C (68 to 77°F) before removing specimens for test.

8.2 For referee testing purposes, subject all sample rolls to a controlled laboratory temperature of  $23 \pm 1^\circ\text{C}$  ( $73.4 \pm 1.8^\circ\text{F}$ ) for a minimum period of 24 h before removing specimens for test.

8.3 Unless otherwise specified, condition all test specimens for a period of 1 h in a controlled laboratory atmosphere at  $23 \pm 1^\circ\text{C}$  ( $73.4 \pm 1.8^\circ\text{F}$ ) and  $50 \pm 2\%$  relative humidity.

## 9. Conditioning for Low Temperature Measurements

9.1 Elastomeric backings of Class 2 tapes may be subject to cold temperature tests. In these cases, place prepared specimens or rolls of tape in a cold room and condition for at least 2 h at the desired temperature (for example, 10°C, 0°C, -10°C, -18°C, etc.).

## 10. Apparatus for Low Temperature Conditioning

10.1 Cold room or cold chamber capable of maintaining the desired cold temperatures during testing.

### WIDTH OF TAPE

#### *Method A—Steel Ruler*

## 11. Apparatus

11.1 A steel scale having divisions at 0.5 mm or 1/64-in. intervals.

## 12. Test Specimens

12.1 Select test specimens of approximately 450 mm (18-in.) lengths of tape taken from each sample roll in accordance with 5.2 and conditioned in accordance with Section 8.

## 13. Procedure

13.1 Place the test specimen, after conditioning, without tension or pressure, adhesive side down on a hard smooth surface. Measure the width perpendicular to the edge with the steel scale at three approximately equally-spaced points along the length.

## 14. Report

14.1 Report the average width in millimetres or inches, plus the maximum and minimum, if specified.

## 15. Precision and Bias

15.1 This test method has been in use for many years, but no statement of precision has been made and no activity is planned to develop such a statement.

15.2 This test method has no bias because the value for width is defined in terms of this test method.

#### *Method B—Caliper*

## 16. Apparatus

16.1 A pair of calipers with a scale length larger than width of the roll of tape, having divisions at 0.5-mm or 1/64-in. intervals.

## 17. Test Specimen

17.1 One roll of tape, conditioned in accordance with Section 8. Unless damaged, no outer layers need to be removed.

## 18. Procedure

18.1 The outer turns of the roll must have clean and sharp edges. Discard any damaged or crushed edges. After conditioning the roll of tape, place it on a table in a vertical position. Open the jaws of the calipers and slide them over the cut edges of the tape so that the scale shaft is parallel to the table. Close the caliper jaws slowly so as to just touch the sides of the tape roll. Be careful not to crush the edges and keep the caliper jaws perpendicular to the edges of the tape. Measure the width perpendicular to the edges in mm (in.) to the nearest 0.5 mm (1/64 in.) at three approximately equally-spaced points along the circumference of the roll.

## 19. Report

19.1 Report the average width in millimetres or inches, plus the maximum and minimum, if specified.

## 20. Precision and Bias

20.1 This test method has been in use for many years, but no statement of precision has been made and no activity is planned to develop such a statement.

20.2 This test method has no bias because the value for width is defined in terms of this test method.

### THICKNESS

## 21. Terminology

21.1 *Definitions of Terms Specific to This Standard:*

21.1.1 *thickness, n*—the perpendicular distance between the opposite surfaces of pressure-sensitive adhesive tape as determined in accordance with this test method.

## 22. Significance and Use

22.1 The thickness is of value in controlling uniformity and providing design data, as well as for use in determining physical and electrical properties.

## 23. Apparatus

23.1 *Thickness Gage*—A dead weight thickness gage as prescribed in Apparatus C of Test Methods D 374, with the following modifications:

23.1.1 *Presser Foot Diameter*—6 mm (¼ in.).

23.1.2 *Anvil Diameter*—6 mm to 50 mm (¼ to 2 in.).

23.1.3 A weighted presser foot so that the total pressure applied to a specimen is equal to 50 ± 5 kPa (7.6 ± 0.5 psi). Calibrate the gage for the actual load exerted by the presser foot.

NOTE 3—Any commercial instrument, including hand-held micrometer, that satisfies 23.1.3 may be used for the thickness measurement.

**24. Test Specimens**

24.1 In accordance with 5.2 and Section 8, prepare and condition specimens of tape of a single thickness a minimum length of 450 mm (18 in.). Let flexible specimens relax for at least 2 min before testing.

**25. Procedure**

25.1 Place the test specimen upon the anvil of the gage, smoothly, with adhesive side down, but without tension. Lower the presser foot onto the tape gradually to minimize any impact force, allowing it to rest upon the tape for 2 s, and then observe the reading to the nearest 0.0025 mm (0.0001 in.) of the thickness gage scale. Make sure no air bubbles are trapped.

25.2 Take three measurements uniformly distributed over the surface of the test specimen.

**26. Report**

26.1 Report the following information:

26.1.1 The average thickness to the nearest 0.0025 mm (0.0001 in.) plus the maximum and minimum, if specified.

**27. Precision and Bias**

27.1 Data obtained from a round-robin investigation on several types of pressure-sensitive adhesive tape indicate that thickness measurements within a single laboratory can be expected to fall within ±5 % of the mean value, and that measurements between laboratories can be expected to fall within ±10 % of the overall mean value.<sup>8</sup>

27.2 A statement of bias is not applicable in view of the unavailability of a standard reference material for this property.

**LENGTH OF TAPE IN A ROLL**

**28. Terminology**

28.1 *Definitions of Terms Specific to This Standard:*

28.1.1 *length of tape in a roll, n*—the number of linear metres or yards of tape wound into a roll as measured in accordance with these test methods.

**29. Significance and Use**

29.1 Measurement of the length of tape in a roll is necessary to ensure receiving correct quantities.

*Method A—Balance Method*

**30. Apparatus**

30.1 *Balance*—Two required, one capable of weighing to the nearest 0.1 g, the other capable of weighing to 1 mg.

30.2 *Steel Rule*—Capable of measuring to the nearest 2 mm (0.1 in.).

**31. Test Specimen**

31.1 A test specimen is a single thickness of pressure-sensitive adhesive tape approximately 1 m (3 ft) long removed from a full roll of tape as received from the manufacturer. Condition each specimen as described in Section 8.

**32. Procedure**

32.1 Determine the number of rolls to be tested for length in accordance with the schedule described in Section 4.

32.2 Remove the core from the roll. Weigh each roll to the nearest 0.1 g (Note 4). Remove a specimen of tape approximately 1 m (3 ft) long from the roll in accordance with the procedure described in Section 5, except DO NOT DISCARD the first three layers. After conditioning, measure the relaxed length of the specimen to the nearest 2 mm or 0.1 in. and weigh to the nearest mg.

NOTE 4—If it is desired to run additional tests on the tape in the roll, it is permissible to first weigh the roll with the core in place and then subtract the weight of the core after all test specimens are removed.

32.3 Calculate the metres per roll as follows:

$$\text{Metres per roll} = \frac{\text{weight of roll less core} \times \text{length of specimen, mm}}{\text{weight of specimen} \times 1000} \tag{1}$$

32.4 Calculate the yards per roll as follows:

$$\text{Yards per roll} = \frac{\text{weight of roll less core} \times \text{length of specimen, in.}}{\text{weight of specimen} \times 36} \tag{2}$$

*Method B—Length Sensor Method*

**33. Apparatus**

33.1 *Length Sensor*—A device to measure length by using a benchmarked rotating wheel which rolls, with low torque and contact pressure, against the circumference of the roll as it unwinds. The apparatus includes a spindle for mounting the tape, the length sensor mechanism, and a read-out and rotating wind-up roll that can be used to either manually or automatically unwind the roll of tape. See Fig. 1.

**34. Procedure**

34.1 Determine the number of rolls to be tested for length in accordance with the schedule described in Section 4. Use only full rolls of tape. Do not remove any outer layer.

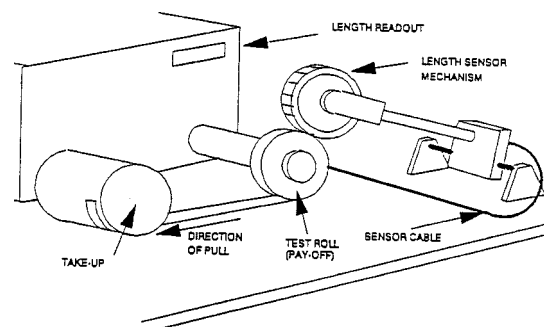

**FIG. 1 Measuring Device for Determination of Length of Tape in a Roll (Length Sensor Method)**

<sup>8</sup> Supporting data are available from ASTM Headquarters. Request RR: D09:1008.



34.2 Mount the roll on the shaft adjacent to the sensor. Position the roll and length sensor so that the sensor is in contact with the circumference of the roll and the leading end of the roll is directly under the sensor. Zero the sensor and manually pull the leading edge of the tape and fix it to the wind-up roll. At the start of the unwinding, make sure that the length sensor maintains good contact with the roll and does not slip or bind. After unwinding is completed, take the reading of the length sensor.

### 35. Report

35.1 Report the following information:

35.1.1 The length of tape in each roll to the nearest 0.1 m (0.1 yd).

### 36. Precision and Bias

36.1 These test methods have been in use for many years, but no statement of precision has been made and no activity is planned to develop such a statement.

36.2 These test methods have no bias because the value for length is defined in terms of these test methods.

## BREAKING STRENGTH AND ELONGATION

### 37. Terminology

37.1 *Definitions of Terms Specific to This Standard:*

37.1.1 *breaking strength of pressure-sensitive adhesive tape, n*—the force required, per unit width, to break the tape when tested under prescribed conditions.

37.1.2 *elongation of pressure-sensitive adhesive tape, n*—the increase in length at break when the tape is tested under prescribed conditions.

37.1.2.1 *Discussion*—In the case of Class 1 tapes, the elongation may include creep in the jaws which is often partially compensated for by “necking” of the specimen.

### 38. Significance and Use

38.1 *Breaking Strength*—Breaking strength of tape is important as a measurement of its uniformity, quality, and ability to withstand tensile stress in application and service.

38.2 *Elongation*—Elongation of tape is important as a measurement of its uniformity and quality, as well as a rough indication of its ability to conform to contours of uneven surfaces.

38.3 In the case of Class 2 tapes, testing at low temperature is necessary to ensure that the tape performs well at cold winter temperatures.

NOTE 5—Values obtained in dry ice chambers and walk-in cold rooms may not be equivalent.

### 39. Apparatus

39.1 *Testing Machine*—A testing machine of the constant-rate-of-extension (CRE) type is preferred. Equip the machine with a device for recording the tensile load and the amount of separation of the grips (Note 6) such that both of these measuring systems are accurate to  $\pm 2\%$  of the breaking load or the amount of separation of the grips. The apparatus must be capable of providing smooth, uniform jaw movement during testing, and the rate adjustable in increments necessary to

produce strain rates that are specified for the materials under test. Equip the machine with a load cell with a capacity such that the breaking load of the material under test falls between 10 and 90 % of the maximum capacity of the load cell.

NOTE 6—A high response speed in the recording system is desirable, particularly when relatively high strain rates are employed. The speed of pen response for recorders is supplied by manufacturers of this equipment. Take care to conduct tests at conditions such that response time (ability of recorder to follow actual load) will produce less than 2 % error.

39.2 *Extension Indicator*—A suitable instrument for determining the distance between two fixed points located within the gage length of the test specimen at any time during the test. It is desirable, but not essential, that this instrument automatically record this distance as a function of the load on the test specimen, or of the elapsed time for the start of the test, or both. If only the latter is obtained, also take load-time data. The extension indicator will usually have a separation of 25 mm (1 in.) between points and be a minimum of 25 mm (1 in.) from both the top and bottom jaws.

39.3 *Holding Fixtures*—The holding fixtures may be any of the following types, provided that the fixture does not cut the specimen or cause slippage:

39.3.1 *Air Jaws*—A device that can be fitted with various types of grips that will clamp onto a specimen through lever arms actuated by compressed air cylinders built into the body. The design provides a high gripping force with standard air pressure. Increased air pressure raises the gripping force to accommodate materials that are often difficult to hold in other types of grips.

39.3.2 *Drum Jaws*—Two smooth cylindrical metallic drums, 50 mm (2 in.) in diameter with a minimum length of 38 mm (1½ in.), suitably marked to aid in proper specimen alignment.

NOTE 7—While drum jaws are permissible, they are not preferred. The design of drum jaws makes it extremely difficult to identify accurately the gage length between jaws.

39.3.3 *Manual Jaws*—A device that can be fitted with various types of grips that will clamp onto a specimen through a manually operated lever.

39.3.4 *Grips*—For manual jaws.

39.3.4.1 *Line Contact* grips have faces designed to concentrate the entire gripping force along a single line perpendicular to the direction of testing stress. This is usually done by combining one standard flat face with an opposing face from which protrudes a half-round.

39.3.4.2 *Flat Faced* grips have their surfaces finished in order to give the best clamping force on the material for test. The choice is determined largely by practical experience with the materials tested. The faces may be smooth-ground, rubber-coated, or serrated. In general, the smooth-ground surface offers high gripping efficiency with most flat materials. The rubber-coated surface is of value with materials that tend to be weakened by pinching at the edge of the jaw face. The serrated surface is recommended for stronger materials that require the greatest gripping action.

NOTE 8—Double coated tape may be used to reinforce gripping, by applying a thin piece of tape on each side of the flat grips.

39.3.4.3 *Cold Chamber*—For cold temperatures testing, if a cold chamber is used for conditioning, it must be equipped with a slot suitable for inserting the tape.

39.3.4.4 *Gloves*—White cotton for handling very cold samples.

**40. Conditioning**

40.1 Condition rolls of tape or specimens according to Sections 6-10 for either room or low temperature testing.

**41. Test Specimens**

41.1 Select specimens in accordance with 5.2 and Section 8. Use specimens that are the width of the tape as received if possible. If it is necessary to trim the specimens due to the machine or jaw width limitations, take extreme care since hand trimming may materially affect the test results. See 5.3 for recommended procedures to slit narrower widths. Put benchmarks on the specimens, if needed.

**42. Procedure**

42.1 *Air Jaws or Manual Jaws*—Position the crosshead at the desired gage length and insert the specimen in the grips. Tighten the movable grip first. If this process applies a preload on the specimen, do not change the balance adjustment to compensate for it. Adjust the initial length of the specimen between contact points to 100 mm (4 in.).

42.2 *Drum Jaws*—Hold the test specimen in place by placing approximately three quarters of a turn of the tape around each holding fixture with the adhesive side in contact with the drum. Place the tape in the center of the drums with the edges parallel to the scribed lines. Adjust the initial length of the specimen between contact points to 100 mm (4 in.).

42.3 Use a constant jaw speed of  $300 \pm 13$  mm/min ( $12 \pm \frac{1}{2}$  in./min), unless otherwise specified.

42.4 Discard breaks that occur at the jaws. Make a minimum of three acceptable determinations.

**43. Calculation**

43.1 Read the breaking strength directly from the recording chart or digital readout.

43.2 Read the percent elongation from the chart or digital readout or record the distance between benchmarks at the instant of break or rupture, and note the jaw separation or the distance between benchmarks at the instant of break or rupture, and calculate the percent elongation as follows:

$$\text{Elongation, \%} = [(D_2 - D_1)/D_1] \times 100 \quad (3)$$

where:

- $D_1$  = original distance between jaws or benchmarks, and
- $D_2$  = distance at instant of break or rupture between jaws or benchmarks.

**44. Report**

44.1 Report the following information:

44.1.1 Temperature conditions,

44.1.2 Average breaking strength expressed in newtons per 10 mm of width (N/10 mm) or in pounds-force per inch of width, plus the maximum and minimum, if specified, and

44.1.3 Average percent elongation, plus the maximum and minimum, if specified.

**45. Precision and Bias**

45.1 Data obtained from a round-robin investigation on several types of pressure-sensitive adhesive tape indicate that breaking-strength measurements within a single laboratory can be expected to fall within  $\pm 15\%$  of the mean value, and elongation measurements to within  $\pm 25\%$  of the mean value. Among different laboratories they can be expected to fall within  $\pm 20\%$  and  $\pm 30\%$ , respectively, of the overall mean value.<sup>8</sup>

45.2 A statement of bias is not applicable in view of the unavailability of a standard reference material for these properties.

**ADHESION STRENGTH TO STEEL AND BACKING**

**46. Terminology**

46.1 *Definitions of Terms Specific to This Standard:*

46.1.1 *adhesion strength of pressure-sensitive adhesive tape, n*—the force necessary to remove the tape from a prescribed surface when measured in accordance with this test method.

**47. Significance and Use**

47.1 In many applications the use of a pressure-sensitive adhesive tape depends upon adhesion strength to give satisfactory performance. The adhesion property is also important in determining the uniformity of quality.

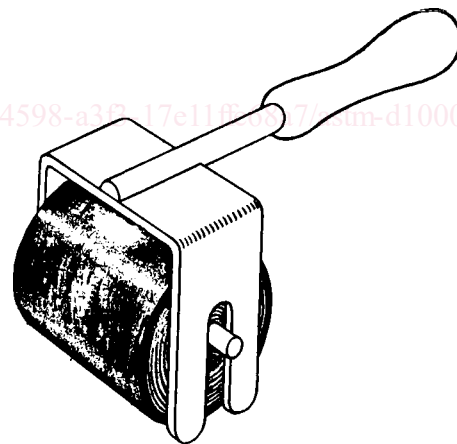

**FIG. 2 Suggested Construction of Roller for Adhesion Strength Test**

**48. Apparatus**

48.1 *Testing Machine*—A crosshead type (constant rate of extension) testing machine, with two clamps with centers in the same plane, parallel with the direction of the motion of the stressing clamp, and so aligned that the clamps will hold the specimen entirely in the same plane, and with a graduated tension weighing device having an accuracy of at least 45 g (0.1 lb) or less per scale division, and preferably 23 g (0.05 lb) or less per scale division. Equip the machine with a device that allows a head separation of a minimum of 250 mm (10 in.).