



Standard Test Method for Freezing Points of High-Purity Hydrocarbons¹

This standard is issued under the fixed designation D 1015; the number immediately following the designation indicates the year of original adoption or, in the case of revision, the year of last revision. A number in parentheses indicates the year of last approval. A superscript epsilon (ϵ) indicates an editorial change since the last revision or reapproval.

1. Scope

1.1 This test method describes a procedure for the precise measurement of the freezing points of high-purity hydrocarbons.

1.2 The values stated in SI units are to be regarded as the standard. The values in parentheses are for information only.

1.3 *This standard does not purport to address all of the safety concerns, if any, associated with its use. It is the responsibility of the user of this standard to establish appropriate safety and health practices and determine the applicability of regulatory limitations prior to use.* For specific hazard statements, see 5.1, 6.1 and 6.2.

NOTE 1—For the calculation of the molal purity of essentially pure compounds from measured freezing points and for procedures to be used for the sampling and determination of purity of certain specific compounds, see Test Method D 1016.

2. Referenced Documents

2.1 ASTM Standards:

D 1016 Test Method for Purity of Hydrocarbons from Freezing Points²

D 1265 Practice for Sampling Liquefied Petroleum (LP) Gases (Manual Method)²

D 4057 Practice for Manual Sampling of Petroleum and Petroleum Products³

3. Summary of Test Method

3.1 The precise experimental measurement of the freezing point is made from interpretation of time-temperature freezing or melting curves.⁴

¹ This test method is under the jurisdiction of ASTM Committee D-2 on Petroleum Products and Lubricants and is the direct responsibility of Subcommittee D02.04.OD on Physical Methods.

Current edition approved Nov. 10, 1999. Published December 1999. Originally published as D 1015 – 49 T. Last previous edition D 1015 – 94.

² *Annual Book of ASTM Standards*, Vol 05.01.

³ *Annual Book of ASTM Standards*, Vol 05.02.

⁴ For details not given here, see Glasgow, A. R., Jr., Rossini, F. D., and Streiff, A. J., "Determination of the Purity of Hydrocarbons by Measurement of Freezing Points," *Journal of Research*, JNBAA, National Institute of Standards and Technology, Vol 35, No. 6, 1945, p. 355.

4. Significance and Use

4.1 The freezing point measured by this test method, when used in conjunction with the physical constants for the hydrocarbons listed in Test Method D 1016, allows the determination of the purity of the material under test. A knowledge of the purity of these hydrocarbons is often needed to help control their manufacture and to determine their suitability for use as reagent chemicals or for conversion to other chemical intermediates or finished products.

5. Apparatus

5.1 *Freezing-Point Apparatus*,⁵ as shown in Fig. 1, Fig. 2, and Fig. 3, comprising a freezing tube, a metal sheath for the freezing tube, a Dewar flask for the cooling bath, a Dewar flask for the warming bath, a stirring mechanism, suitable clamps and holders for the parts, and the absorption tubes. The outer walls of all Dewar flasks can be covered with adhesive tape to minimize danger from glass in case of breakage. (**Warning:** When using liquid nitrogen as a refrigerant, provide a means to prevent condensation of oxygen in the space between the freezing tube and the metal sheath and subsequent sealing of the space by ice forming on the asbestos collar. Provide the metal sheath with suitable openings in the *sides* and *bottom*. Failure to do this may result in breakage of the freezing tube when the liquefied oxygen evaporates within the sealed space.)

5.2 *Resistance Bridge*,⁶ Mueller type, reading from 0.0001 to 50 Ω , in steps of 0.001 Ω .

⁵ A suitable apparatus is available from Reliance Glass Works, Inc., Bensenville, IL, Cat. No. R6878-100.

⁶ Apparatus described in 5.2, 5.3, 5.4 and 5.5 was manufactured by the Leeds and Northrup Co., Philadelphia, PA, under the following catalog numbers: resistance bridge, No. 8069 B; platinum resistance thermometer, No. 8163 B; galvanometer, highest precision, No. 2284 D; galvanometer, routine precision, No. 2430 A; lamp and scale, No. 2100. The galvanometer, routine precision, No. 2430-A, and the lamp and scale, No. 2100, are still available from Leeds and Northrup. The platinum resistance thermometer, No. 8163-B, is no longer available from Leeds and Northrup, but is available with the same part number from Yellow Springs Instrument Co., Yellow Springs, OH. The resistance bridge No. 8069-B, and the galvanometer, highest precision, No. 2284-D, are no longer available; however, they may be obtainable from instrument exchanges or used equipment suppliers. If other available instrumentation is substituted for the original, the precision statement of Section 13 will not apply.

Legend for Fig. 1 (see following page):

- A—Bracket for motor, with rubber pad.
- B—Motor, with reduction gears, to give 120 r/min.
- C—Coupling. (See Fig. 3).
- D—Wheel. (See Fig. 3).
- E—Steel rod. (See Fig. 3).
- F—Bearing. (See Fig. 3).
- G—Support for bearing. (See Fig. 3).
- H—Support for freezing tube.
- I—Adjustable clamp holder.
- J—Clamp for freezing tube.
- K—Stirrer. (See Fig. 3).
- L—Thermometer.
- M—Tube for inlet of dry air, with 12/5 spherical joint.
- M'—12/5 spherical joint connection to rotameter.
- N—Cork stopper, with holes as shown, plus a small hole for the “seed” wire.
- O—Freezing tube, with silvered jacket. (See Fig. 2.)
- P—Stopcock on freezing tube.
- P'—Stopcock (high vacuum) to drying tube.
- P''—Stopcock (high vacuum) to vacuum line.
- Q—Asbestos collar.
- R—Brass cylinder, 317.5 mm (12½ in.) in length and 54 mm (2⅛ in.) in inside diameter, with bakelite collar; when liquid nitrogen is used, the metal shield must be provided with suitable openings in sides and bottom (see 5.1). If liquid air is used, the metal shield should be constructed so as to keep hydrocarbon from contact with liquid air (see 6.2).
- S—Dewar flask, for cooling or warming bath; approximate inside diameter, 101 mm (4 in.); approximate inside depth, 330 mm (13 in.).
- T—Asbestos pad at bottom of cylinder R.
- U—Wood block support.
- V—Table top.
- W—Wall.
- X, X'—Spherical joint, 18/7.
- Y—Standard metal (copper or brass) to glass taper connections soldered.
- Z—Connection to vacuum pump.
- a—Anhydrous calcium sulfate, with indicator.
- b—Anhydrous magnesium perchlorate, granular.
- d—Separating layer of glass wool.
- e—Ascarite.
- f—Anhydrous calcium sulfate.
- g—To air.
- h—To source of compressed air.
- i—Flow meter, for rates of 10 to 20 mL/min.

5.3 *Platinum Resistance Thermometer*, ⁶ precision grade, with a resistance near 25.5 Ω at 0°C, calibrated by the National Institute of Standards and Technology for the range from –190 to 500°C.

5.4 *Null Point Indicator*, may be either a galvanometer or a microvolt ammeter.

5.4.1 *Galvanometer*, ⁶ having a sensitivity of 0.1 mV/m at 1 m for highest precision or a sensitivity of 0.5 mV/m at 1 m for routine precision.

5.4.2 *Microvolt Ammeter*. ⁷

5.5 *Lamp and Scale*,⁶ any suitable type.

5.6 *Stopwatch or Clock*, preferably having graduations in minutes and hundredths of minutes.

5.7 *High-Vacuum Oil Pump*, ⁸ capable of evacuating the jacket of the freezing tube to a pressure of 0.133 Pa in 10 min or less.

5.8 *Seeding Apparatus*, as shown in Fig. 4, for inducing crystallization.

5.9 *Silica Gel Funnel*, as shown in Fig. 5, for filtering compounds through silica gel to remove water. To be used only when specified in Test Method D 1016.

⁷ Model No. 155, manufactured by Keithley Instruments, Inc., 28775 Aurora Rd., Cleveland, OH, or equivalent, has been found satisfactory for this purpose.

⁸ A suitable pump is available from Boekel Industries, Inc. Philadelphia, PA, Cat. No. 91105.

6. Materials

6.1 *Carbon Dioxide Refrigerant*—Solid carbon dioxide in a suitable liquid. (**Warning:** Extremely cold (–78.5°C). Liberates heavy gas which can cause suffocation. Contact with skin causes burns or freezing, or both. Vapors can react violently with hot magnesium or aluminum alloys.) Acetone is recommended. (**Warning**—Extremely flammable. Harmful if inhaled. High concentrations can cause unconsciousness or death. Contact can cause skin irritation and dermatitis. Use refrigerant bath only with adequate ventilation.)

6.2 *Liquid Nitrogen or Liquid Air*— (**Warning:** Extremely cold. Liberates gas which can cause suffocation. Contact with skin causes burns or freezing, or both. Vapors can react violently with hot magnesium or aluminum alloys.) For use as a refrigerant. If obtainable, liquid nitrogen is preferable because of its safety.

6.2.1 Use liquid nitrogen refrigerant only with adequate ventilation. If liquid air is used as a refrigerant, it is imperative that any glass vessel containing hydrocarbon or other combustible compound and immersed in liquid air be protected with a suitable metal shield. The mixing of a hydrocarbon or other combustible compound with liquid air due to the breaking of a glass container would almost certainly result in a violent explosion. If liquid nitrogen is used as a refrigerant, no hydrocarbon sample should ever be permitted to cool below the condensation temperature of oxygen (–183°C at 1 atm). This

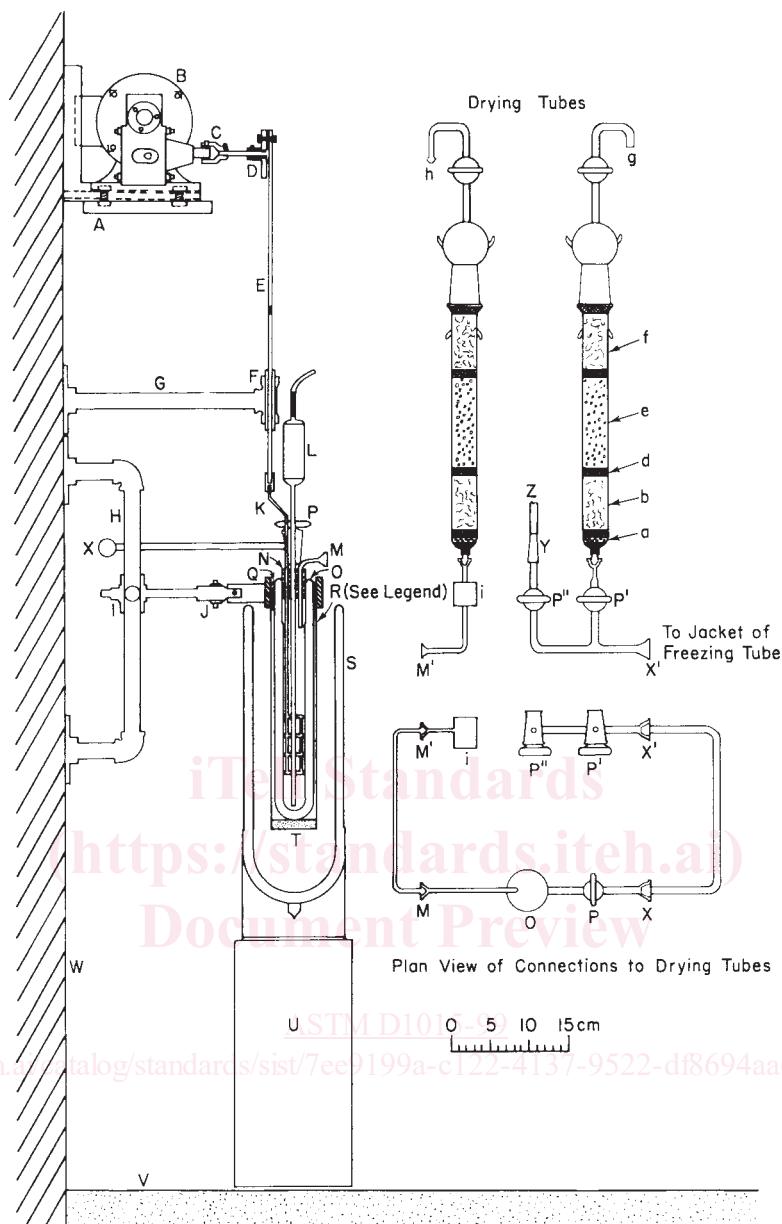

FIG. 1 Assembly of the Freezing-Point Apparatus (See preceding page for legend.) (continued)

would not be likely to occur in normal operation, but might occur if the apparatus were left unattended for some time.

6.3 *Silica Gel*, for use in silica gel funnel.⁹ If the gel has been exposed to the atmosphere because of punctured or loosely sealed containers, before use, dry the gel in a shallow vessel at 150 to 205°C for 3 h, then transfer while hot to an air-tight container.

7. Sampling

7.1 *Sampling from Bulk Storage:*

⁹ A satisfactory gel of 28 to 200 mesh may be obtained from the Davison Chemical Co., Baltimore 3, MD. Specify grade 12.

7.1.1 *Cylinder*—Refer to Practice D 1265 for instructions on introducing samples into a cylinder from bulk storage.

7.1.2 *Open Containers*—Refer to Practice D 4057 for instructions on introducing samples into open-type containers from bulk storage.

8. Calibration of Thermometric System and Conversion of Resistance Readings to Temperature

8.1 *Calibration of Resistance Bridge*— The Mueller type resistance bridge should have its calibration checked at appropriate intervals by measurement of a suitable external certified resistance, with intercomparison of the resistances of the bridge.

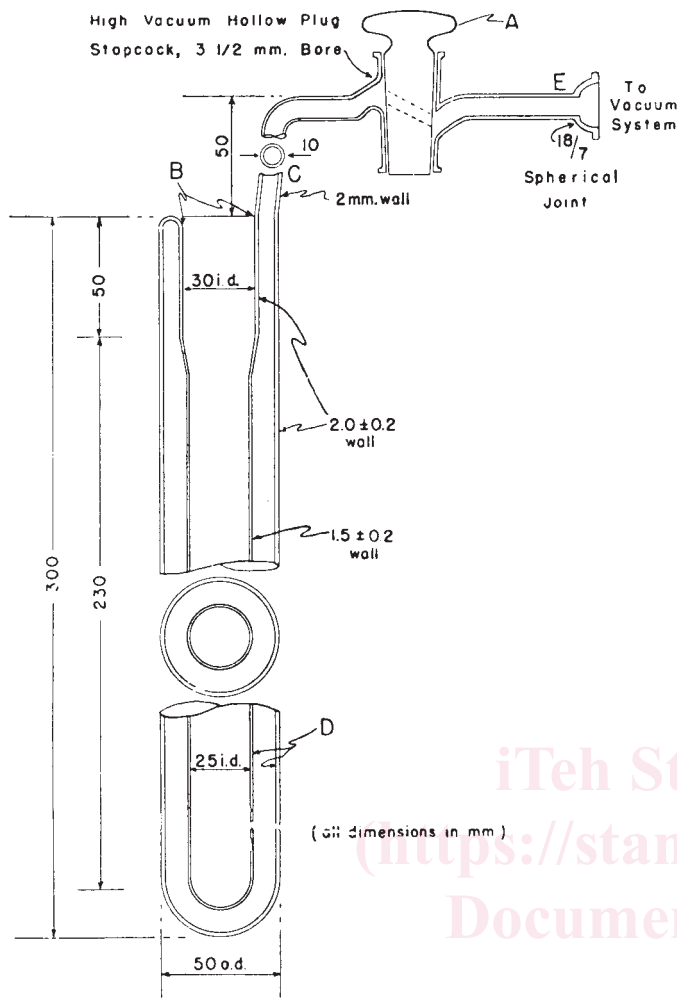

A—High-vacuum stopcock, hollow plug, oblique 3½-mm bore.
 B—Inside opening of freezing tube, which must have no bulge at this point.
 C—Slanted connection to jacket of freezing tube.
 D—Internal walls of jacket of freezing tube, silvered.
 E—Spherical joint, 18/7.

FIG. 2 Details of the Freezing Tube

8.2 *Calibration of Resistance Thermometer*—The platinum-resistance thermometer is provided with four calibration constants certified by the National Institute of Standards and Technology for use in converting the resistance of the thermometer into temperature according to the International Temperature Scale, for use in the range from -190 to 500°C, namely, R_0 , C , δ , and β . If the thermometer has been properly constructed and annealed, the certified constants C , δ , and β will not change significantly with time, but the value of R_0 may change slightly.

NOTE 2—*International Practical Temperature Scale*—In 1968 a new IPTS was adopted, replacing the previous scale in use since 1948. The 1948 IPTS was based on the boiling point of oxygen, the sulfur point, ice point, and steam point. The 1968 IPTS is based on the triple point of water, tin point, zinc point, and boiling point of oxygen. The differences in the two temperature scales T_{68} – T_{48} vary. Above 100°C the differences are plus; below 100°C they may be either plus or minus.

If the measured freezing point is to be used for the determination of purity according to Test Method D 1016, the measured freezing point t_f ,

and the freezing point of the pure material t_{f_0} , should be on the same temperature scale. The values of t_{f_0} given in Test Method D 1016 are on the 1968 IPTS. Therefore, values of t_f determined using thermometers calibrated on the 1948 scale should be converted to their 1968 IPTS equivalent. This conversion can be made by applying the appropriate correction from Table 1.

8.3 *Checking of the Ice Point*—Frequent measurements (at least once every month) should be made of the resistance of the given platinum thermometer at the ice point, 0°C, as measured on the given resistance bridge.¹⁰ This value should differ only slightly from the certified value of R_0 . If the difference becomes appreciable (approaching 0.001 Ω), the calibration of the bridge should be checked. If the bridge has not changed, the change has occurred in the thermometer, and a recalibration of it is recommended.

8.4 *Conversion of Resistance Readings to Temperature*—When determinations are made on a number of substances having freezing points at different temperatures, time will be saved by making up a table giving values of the resistance, R , for each unit degree of temperature in the given range. Values of resistance for unit degrees, for the ranges from -190 to +50°C and +50 to 290°C, with differences between successive unit degrees tabulated for linear interpolation (which is permissible), may be easily placed on a single 300 by 400-mm (14 by 16-in.) sheet for each range. Calculate values for the resistance, R , from unit values of temperature, t , by means of one of the following equations:

For temperatures below 0°C:

$$R = R_0 \{1 + Ct[(1 + 0.01 \delta) - 10^{-4} \delta t - 10^{-3} \beta(t - 100)t^2]\} \quad (1)$$

For temperatures above 0°C:

$$R = R_0 \{1 + Ct[(1 + 0.01 \delta) - 10^{-4} \delta t]\} \quad (2)$$

where:

- t = given temperature, °C, on the International Temperature Scale (see Note 2),
- R = resistance of the thermometer in ohms at the temperature t ,
- R_0 = resistance of the thermometer in ohms at 0°C, and
- C , δ , and β = constants certified for the given platinum thermometer by the National Institute of Standards and Technology.

9. General Procedure for Determining a Freezing Curve

9.1 Assemble the apparatus, with no refrigerant and no sample yet in place, but with a stream of air, freed of carbon dioxide and water, flowing at a rate of 10 to 20 mL/min. Fill the jacket of the freezing tube with air freed of carbon dioxide and water.

9.2 As required, the operator must be prepared to induce crystallization in the sample as soon as possible after the temperature has passed below the freezing point of the sample

¹⁰ The ice point may be measured according to the procedure described by J. Busse, "Temperature, Its Measurement and Control in Science and Industry," Section VIII, Reinhold Publishing Corp., 1941, p. 241. See also "Notes to Supplement Resistance Thermometer Certificates." National Institute of Standards and Technology, 1949.

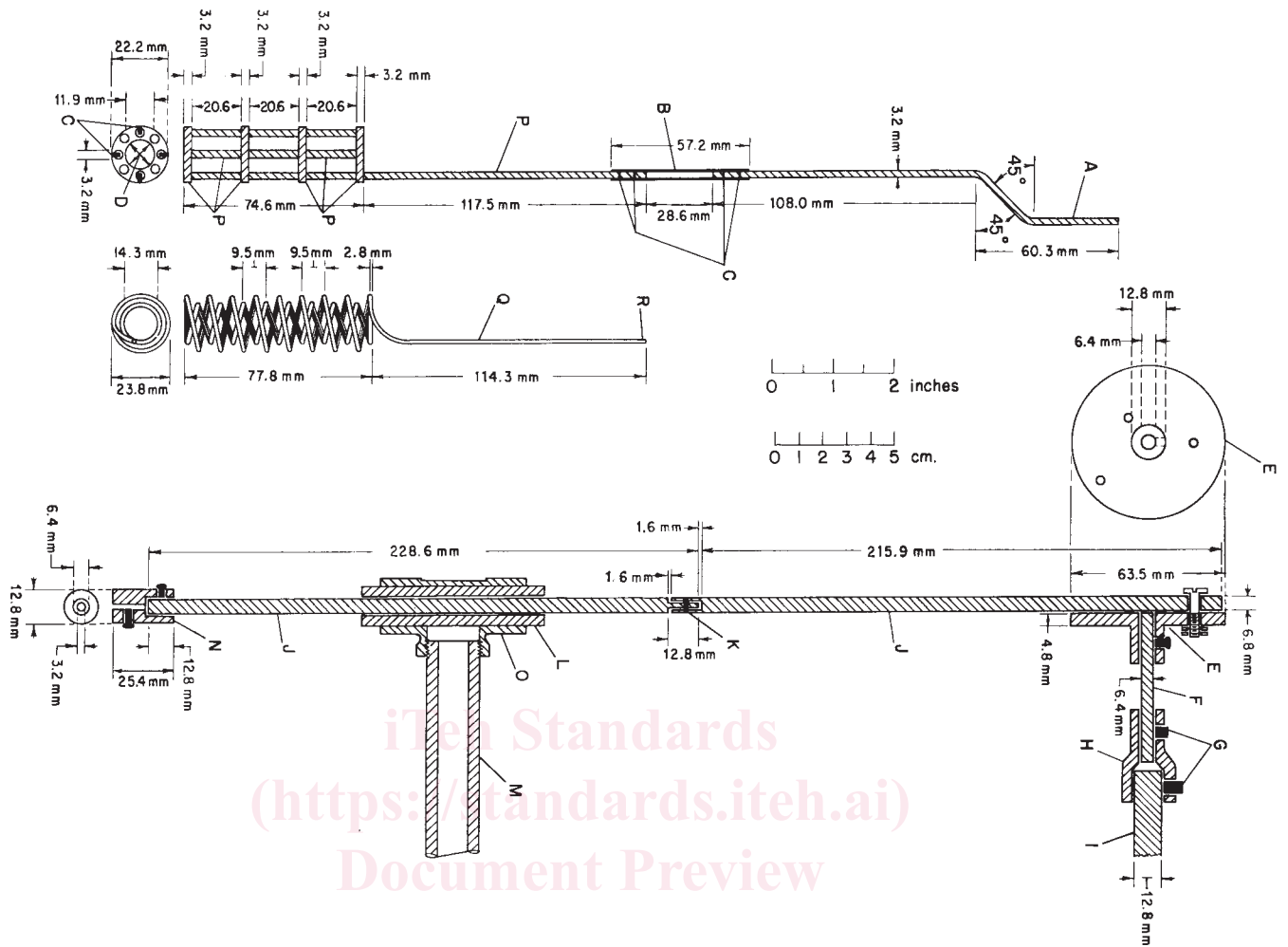

- A—Stainless steel rod, round.
- B—German-silver tube.
- C—Pins.
- D—Holes, 3.2 mm (1/8 in.) in diameter.
- E—Brass wheel, with three holes; tapped for machine screws, spaced 12.7 mm (1/2 in.), 19.05 mm (3/4 in.), and 25.4 mm (1 in.) from center; normal position is 19.05 mm (3/4 in.) from center.
- F—Steel rod.
- G—Set screws.
- H—Brass coupling.
- I—Steel shaft.
- J—Steel rod, round.
- J—Steel rod, square.
- K—Connecting pin.
- L—Brass sleeve bearing.
- M—Steel pipe, 12.7 mm (1/2 in.) nominal size.
- N—Brass coupling.
- O—Brass tee.
- P—Aluminum.
- Q—Double helical stirrer, made by winding 1.6 mm (1/16 in.) diameter nichrome wire downwards on a cylinder 14.3 mm (9/16 in.) in outside diameter to form the inner helix, and then upwards over a cylinder 20.7 mm (13/16 in.) in outside diameter to form the outer helix, with the two ends silver soldered together.
- R—Place where shaft of the double helical stirrer is joined to the stirrer shaft.

Metric Equivalents

mm	0.794	11.91	4.763	24	74.612	77.8	9.53	22.23	28.6	60.33	117.5	6.4	57.15	108	63.5	114.3	215.98
in.	1/32	15/32	3/16	15/16	2 15/16	37/16	3/8	7/8	1 1/8	2 3/8	4 5/8	1/4	2 1/4	4 1/4	2 1/2	4 1/2	1/2

FIG. 3 Details of the Stirring Assembly and Supports

(to prevent excessive undercooling). In some cases, crystallization may be induced by introducing into the sample at the appropriate time a small rod (ABC in Fig. 4) which has been kept at an appropriate lower temperature (near 0°C, -80°C,

or -180°C) (J in Fig. 4). In other cases, crystallization can be induced by introducing into the sample at the appropriate time crystals of the sample on the coiled end of the small rod (ABC in Fig. 4). When inducing crystallization, the cold rod (with or

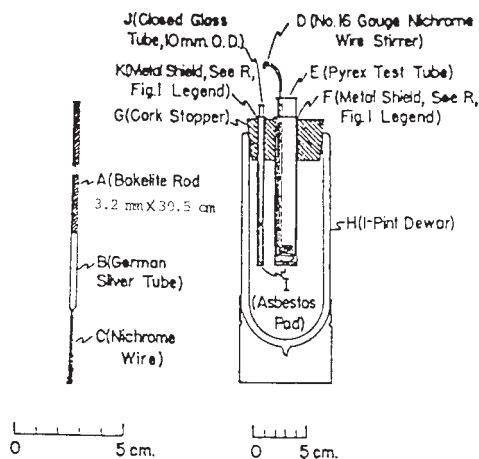

- A—Bakelite rod; 3.2 mm (1/8 in.) in diameter, 317.5 mm (12½ in.) in length.
- B—German-silver tube, sealed to nichrome wire on one end and "sweated" on bakelite rod on other.
- C—Nichrome wire, 1.191 mm (3/64 in.) in diameter, with a helical coil on one end.
- D—Stirrer, nichrome wire 1.6 to 3.2 mm (1/16 to 1/8 in.) in diameter, coiled on one end.
- E—Pyrex test tube.
- F—Metal shield; for precautions in use of liquid nitrogen and liquid air see R in legend to Fig. 1 and 5.1 and 6.2.
- G—Cork stopper, with holes as shown.
- H—Dewar flask, 1 pint size.
- I—Asbestos paddings.
- J—Pyrex glass tube closed on one side.
- K—Metal shield; for precautions in use of liquid nitrogen and liquid air see R in legend to Fig. 1 and 5.1 and 6.2.

FIG. 4 Apparatus for Inducing Crystallization

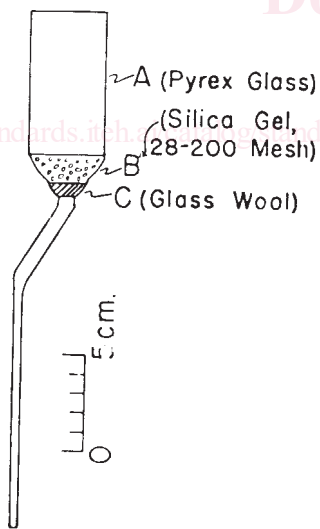

- A—Filter funnel, with extension as shown, pyrex glass.
- B—Adsorbent, silica gel, 28 to 200 mesh.
- C—Glass wool.

FIG. 5 Silica Gel Funnel

without crystals) should be immersed in the sample in the freezing tube for about 2 s (if necessary, this is repeated every 2 or 3 min). These crystals are made by placing several millilitres of the sample in a small test tube, incased in a thin metal tube, as shown at E in Fig. 4, immersed in a refrigerant

whose temperature is below the freezing point of the sample. A slurry or mush of liquid and crystals is produced. The rod (ABC in Fig. 4), with wet crystals adhering to the helical coil C, is raised above the liquid level in the tube E and held in position with a cork stopper until required for seeding.

9.3 Fill the Dewar flask surrounding the freezing tube with the appropriate refrigerant. Temporarily remove the thermometer and stopper and then introduce the sample (usually 50 mL of liquid in amount) through a pipet if the material is normally liquid, or by pouring the refrigerated liquid sample through the tapered male outlet of the reservoir trap (E in Fig. 1, of Test Method D 1016) if the material is normally gaseous. When specified in Test Method D 1016, filter the sample directly into a freezing tube (O in Fig. 1,) through silica gel to remove water. A detailed drawing of a funnel used for this purpose is shown in Fig. 5. Each time a freezing or melting curve is determined after the sample is melted, it is necessary to remove the sample from the freezing tube and refilter it through silica gel into a dry freezing tube to remove water. When the sample is volatile or normally gaseous at room temperature, cool the freezing tube before introduction of the sample in order to minimize loss by evaporation. Continue the flow of air (freed of carbon dioxide and water) into the freezing tube in order to keep out water vapor. Start the stirrer and allow the sample to cool down to within about 15°C of the freezing point, then begin evacuation of the jacket of the freezing tube.

9.4 Observe the time and the resistance of the thermometer at even intervals of 0.02 to 0.05 Ω (about 0.2 to 0.5°C) to determine the rate of cooling, which is continually changing as the pressure in the jacket of the freezing tube is reduced. Care must be taken to close the stopcock to the freezing tube when the desired cooling rate is obtained. In case the cooling rate is allowed to become too slow, the pressure and likewise the cooling rate can be increased by bleeding in air (freed of carbon dioxide and water) through stopcocks P' and P (Fig. 1,). When a cooling rate is obtained that will give a change of 1°C in about 1 to 3 min in the range of about 5 to 10°C above the freezing point, close the stopcock controlling the jacket of the freezing tube. (The optimum rate of cooling will vary with the material being examined.)

9.5 When the temperature reaches a point about 5°C above the expected freezing point, record the time to 1 s (or 0.01 min) at which the resistance of the thermometer equals 0.1 or 0.05 Ω. At the appropriate time (see 9.2) induce crystallization. The beginning of crystallization will be accompanied by a halt in the cooling of the liquid. After recovery from undercooling is substantially complete, record the resistances at intervals of about 1 min. If a galvanometer is being used, also record the galvanometer scale at full sensitivity and with no current through the galvanometer. These observations, together with the sensitivity of the galvanometer system in terms of ohms per millimetre of scale reading, yield a sensitivity of nearly 0.0001°C. Approximately equal sensitivity is obtained when using a microvolt ammeter. Continue observations until the stirrer begins to labor, then stop the stirrer. After several minutes (when a steady rate is obtained) make alternate N and R readings through the commutator at fixed intervals of about