



Designation: D 5362 – 03

Standard Test Method for Snagging Resistance of Fabrics (Bean Bag)¹

This standard is issued under the fixed designation D 5362; the number immediately following the designation indicates the year of original adoption or, in the case of revision, the year of last revision. A number in parentheses indicates the year of last approval. A superscript epsilon (ϵ) indicates an editorial change since the last revision or reapproval.

1. Scope

1.1 This test method determines the snagging resistance of a fabric.

1.2 Studies of fabric snagging have shown that this test method is suitable for a range of woven and knitted fabrics made from textured or untextured filament yarns or spun yarns or combinations of these yarns.^{2,3} This test method is not suitable for (1) open construction fabrics (such as a net) because the pins in the test chamber will snag the bean bag rather than the specimen, (2) heavy or stiff fabrics that cannot be made into a cover for the bean bag, and (3) tufted or nonwoven fabrics because the apparatus is designed for woven and knitted fabrics.

1.3 The values stated in either acceptable metric units or in other units shall be regarded separately as standard. The values stated in each system may not be the exact equivalents; therefore, each system must be used independently of the other, without combining values in any way. In case of referee decisions the metric units will prevail.

1.4 *This standard does not purport to address all of the safety concerns, if any, associated with its use. It is the responsibility of the user of this standard to establish appropriate safety and health practices and determine the applicability of regulatory limitations prior to use.* Specific precautionary statements are given in Section 7.

2. Referenced Documents

2.1 ASTM Standards:⁴

D 123 Terminology Relating to Textiles

D 1335 Test Method for Tuft Bind of Pile Floor Coverings

D 1776 Practice for Conditioning and Testing Textiles
D 2724 Test Methods for Bonded, Fused, and Laminated Apparel Fabrics
D 3136 Terminology Relating to Care Labeling for Apparel, Textile, Home Furnishing, and Leather Products
D 3939 Test Method for Snagging Resistance of Fabrics (Mace)
D 4467 Practice for Interlaboratory Testing of a Textile Test Method That Produces Non-Normally Distributed Data
D 4850 Terminology Relating to Fabrics
2.2 AATCC Standards:⁵
65 Test Method for Snag Resistance of Women's Nylon Hosiery (see Note 1)
135 Test Method for Dimensional Changes in Automatic Home Laundering of Woven and Knit Fabrics

NOTE 1—In 1988 the AATCC voted to withdraw this test method from their technical manual; however, the ASTM task group on fabric snagging decided it should be listed as an alternative for testing open construction fabrics.

3. Terminology

3.1 Definitions:

3.1.1 For definitions of textile terms used in this test method: color contrast, in textiles; distortion in fabrics; protrusion, in fabrics; snag, in fabrics; snagging resistance, in fabrics; refer to Terminology D 4850.

3.1.2 For definitions of other textile terms used in this test method, refer to Terminology D 123.

4. Summary of Test Method

4.1 A fabric specimen is made into a cover for a bean bag. Then the specimen and bean bag unit is tumbled for 100 revolutions in a cylindrical test chamber fitted on its inner surface with rows of pins. The degree of fabric snagging is evaluated by (1) comparison of the tested specimens with visual rating standards that may be either snagged fabrics or photographs of snagged fabrics, or (2) using a point system. The resistance to snagging is rated on a numerical scale ranging from 5 (no or insignificant snagging) to 1 (very severe snagging).

⁵ Available from American Association of Textile Chemists and Colorists, P.O. Box 12215, Research Triangle Park, NC 27709.

¹ This test method is under the jurisdiction of ASTM Committee D13 on Textiles and is the direct responsibility of Subcommittee D13.59 on Fabric Test Methods, General.

Current edition approved Oct. 1, 2003. Published October 2003. Originally approved in 1993. Last previous edition approved in 1997 as D 5362 – 97a.

² Stuckey, W. C., and El Shiekh, A., "Snags in Snag Testing of Knits", in *Sense and Nonsense in Knit Testing*, American Association of Textile Chemists and Colorists, 1975, pp. 45–53.

³ Cary, R. T., "Bean Bag Snag Tester: A System of Evaluation", *Textile Research Journal*, Vol 51, No. 2, 1981, pp. 61–63.

⁴ For referenced ASTM standards, visit the ASTM website, www.astm.org, or contact ASTM Customer Service at service@astm.org. For *Annual Book of ASTM Standards* volume information, refer to the standard's Document Summary page on the ASTM website.

5. Significance and Use

5.1 *Acceptance Testing*—This test method may be used for acceptance testing of commercial shipments of fabrics because the precision is acceptable (see 15.1).

5.1.1 If there are differences of practical significance between reported test results for two laboratories (or more), comparative tests should be performed to determine if there is a statistical bias between them, using competent statistical assistance. As a minimum, use the samples for such a comparative test that are as homogeneous as possible, drawn from the same lot of material as the samples that resulted in disparate results during initial testing and randomly assigned in equal number to each laboratory. The test results from the laboratories involved should be compared using a statistical test for unpaired data, at a probability level chosen prior to the testing series. If bias is found, either its cause must be found and corrected, or future test results for that material must be adjusted in consideration of the known bias.

5.2 This test method may be used for quality control testing of fabrics during manufacturing and product comparisons of different fabrics by manufacturers, retailers, and users. This test method may also be used by researchers to examine the effect of new fibers, yarns, fabric constructions, and finishes on the snagging resistance of fabrics.

5.3 This test method may be used to test the snagging resistance of most apparel and home furnishings fabrics. However, a different test method (see 5.3.1) may be needed for different types of fabrics and different end-uses (such as towels, swimwear, slacks, and upholstery).

5.3.1 Some fabrics which may not be suitable for this test method are described in 1.2. Many open construction fabrics can be tested for snagging resistance using AATCC Test Method 65. Many heavy or stiff fabrics can be tested for snagging resistance using Test Method D 3939. The snagging resistance of many pile floor coverings can be tested by Test Method D 1335.

5.4 Because fabric snagging can be affected by laundering or drycleaning, it may be advisable to test the snagging resistance of a fabric before and after laundering or drycleaning.

5.5 The snagging resistance of a specific fabric varies with individual wearers and general conditions of use. Therefore, it can be expected that garments of the same fabric will show a fairly wide snagging resistance spectrum after wear and much greater variation in wear than in replicate fabric specimens subjected to controlled laboratory tests. This factor should be considered when adopting levels of acceptability for any specification that includes snagging resistance.

5.6 Snags observed in worn garments vary appreciably in number and appearance. The appearance of a snag depends particularly on (1) the degree of color contrast between the snag and the surrounding area of the fabric, or, (2) the presence of long distortions or long protrusions. These conditions are not evaluated when snagging is rated solely on the number of snags. See Section 3 for a description of terminology such as color contrast, distortion, and protrusion See Figs. 1-3 . Because the overall acceptability of a specific fabric is dependent on both the characteristics of the snags and other factors affecting fabric appearance, it is recommended that fabrics tested in the laboratory be evaluated with regard to the defects which may be visually observed and not rated solely on the number of snags developed. A series of visual rating standards (see 6.7) may be set up to provide a basis for the ratings. The visual rating standards are most advantageous when the tested laboratory specimens correlate closely in appearance with fabrics from a wear test; for example when tested laboratory specimens and fabrics from a wear test show similar color contrasts. In the preceding example, a series of fabrics from the wear test would be a good choice for the fabric standards described in 6.7.2. Also a point rating system may be used that considers the number of the snags and the appearance

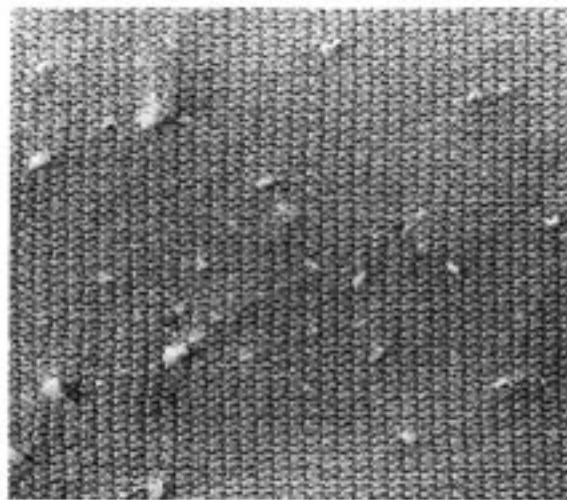

FIG. 1 A Snagged Specimen With Many Protrusion But No Distortions

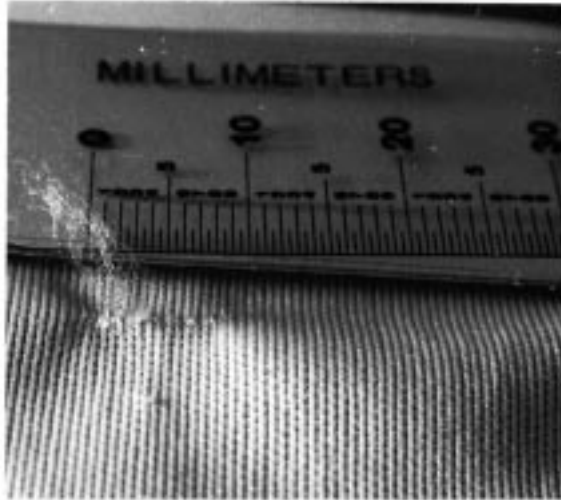

FIG. 2 A Snag That Includes Both a Protrusion and a Distortion



FIG. 4 The Bean Bag Snag Tester With Two Test Chambers

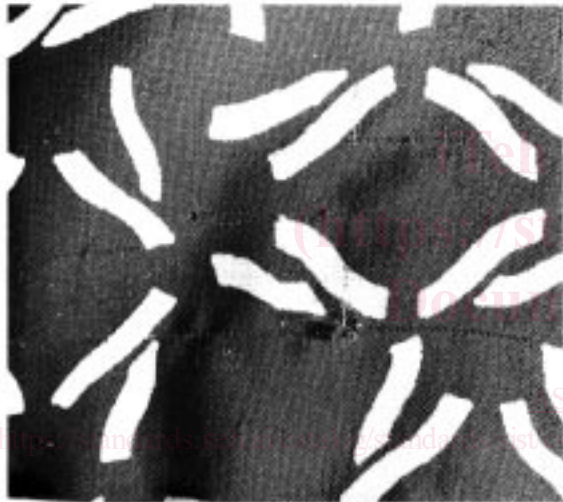

FIG. 3 A Snagged Specimen With Color Contrasts (Yarn Shifted from Dark Area to Light Area)

of the snags. (See 13 for additional information about snags, protrusions, distortions, and color contrasts. Also, see Figs. 1-3).

6. Apparatus and Materials

6.1 *Bean Bag Snag Tester*⁶, as shown in Fig. 4. Each rotating cylinder (2.1 ± 0.3 rad/s or 20 ± 3 r/min) is fitted with a snagging basket which is a removable framework of eight baffle bars attached at each end to plastic disks. Each baffle bar has a series of nine pins protruding from it. Each baffle bar is locked in the plastic disks so that when a baffle bar is exactly at the bottom of the cylinder, an angle of 0.5 ± 0.1 rad or 30

$\pm 5^\circ$ exists between the pins on that baffle bar and a theoretical horizontal line passing through the end of the baffle bar.

6.1.1 *Bean Bags*⁶, filled with shot and each weighing 450 ± 10 g or 1.0 ± 0.02 lb. A minimum of two bean bags is required, but six bean bags are suggested for efficiency.

6.2 *Specimen Template*, made of approximately 2 mm or 0.1 in. thick poster board, plastic or metal with dimensions of 215 mm by 115 mm or 8.5 in. by 4.5 in.

6.3 *Sewing Machine*, with a sewing needle that is appropriate for the fabric being tested for snagging resistance, or

6.4 *Sharps Hand Sewing Needle*.

6.5 *Sewing Thread*, cotton, Tex ticket 35 to 50, or equivalent polyester and cotton.

6.6 *Standard Calibration Fabric*, having an established snagging resistance rating that has been agreed upon by the purchaser and the supplier. (No standard calibration fabric has been specified by Subcommittee D13.59.)

6.7 *Visual Rating Standards* (for Option A):

6.7.1 *Photographic Standards*, a series of photographs of tested specimens that show the degrees of snagging, such as the Imperial Chemical Industries (ICI) photographs,⁷ or

6.7.2 *Fabric Standards*, a series of tested specimens or fabrics from a wear test that show the degrees of snagging (see 5.6 and Note 2).

NOTE 2—Fabric standards should be stored and handled under conditions that will preserve their original form and appearance. Mount the fabric standards using white poster board, plastic or metal framing.

6.8 *Equipment for Fabric Evaluation for Option A*, for illumination and simultaneous viewing of specimens and visual rating standards:

6.8.1 *Apparatus for Fabric Evaluation*:

⁶ The sole source of supply of the apparatus known to the committee at this time is (SDL Atlas LLC, 1813A Associated Lane, Charlotte, NC 28271). If you are aware of alternative suppliers, please provide this information to ASTM Headquarters. Your comments will receive careful consideration at a meeting of the responsible technical committee.

⁷ The sole source of supply of the apparatus known to the committee at this time is (SDL Atlas LLC, 1813A Associated Lane, Charlotte, NC 28271). If you are aware of alternative suppliers, please provide this information to ASTM Headquarters. Your comments will receive careful consideration at a meeting of the responsible technical committee.

6.8.1.1 *Viewing Cabinet*⁸, (see Fig. 5) having a single cool white fluorescent tube with a correlated color temperature of 4100 to 4500 K.

6.8.1.2 *Specimen Viewing Mask* (White), made of approximately 2 mm or 0.1 in. thick poster board, plastic or metal with outer dimensions of 100 mm by 100 mm or 4 in. by 4 in. and a center cutout of 75 mm by 75 mm or 3 in. by 3 in.

6.8.1.3 *Photographic Standard Viewing Mask* (White), made of approximately 2 mm or 0.1 in. thick poster board, plastic or metal with outer dimensions of 130 mm by 95 mm or 5.2 in. by 3.8 in. and a center cutout of 75 mm by 75 mm or 3 in. by 3 in. The dimensions of this mask are for photographic standards (see 6.7.1) which have outer dimensions of 130 mm by 95 mm or 5.2 in. by 3.8 in. in size. Larger or smaller photographic standards will need a mask with corresponding outer dimensions. All photographic standard viewing masks must have the same center cutout viewing dimensions as the specimen viewing mask.

⁸ The sole source of supply of the apparatus known to the committee at this time is Standard Scientific Supply Company, 601 West Market Street, Bethlehem, PA 18018-5208. If you are aware of alternative suppliers, please provide this information to ASTM Headquarters. Your comments will receive careful consideration at a meeting of the responsible technical committee.

6.8.1.4 *Fabric Standard Viewing Mask* (White), made of approximately 2 mm or 0.1 in. thick poster board, plastic or metal and with the outer dimensions the same as the dimensions of the fabric standard (see 6.7.2) and a center cutout of 75 mm by 75 mm or 3 in. by 3 in.

6.9 *Equipment for Fabric Evaluation for Option B*, for illumination and viewing of specimens:

6.9.1 *Desk Lamp*, having a single cool white fluorescent tube with a correlated color temperature of 4100 to 4500 K.

6.9.2 *Specimen Viewing Mask* (White), made of approximately 2 mm or 0.1 in. thick poster board, plastic or metal with outer dimensions of 100 mm by 100 mm or 4 in. by 4 in. and a center cutout of 75 mm by 75 mm or 3 in. by 3 in.

6.10 *Optional Equipment:*

6.10.1 *Tumble Dryer*, as described in AATCC Test Method 135.

6.10.2 *Washing Machine*, as described in AATCC Test Method 135.

6.10.3 *Detergent*, heavy duty granule, the 1993 AATCC Standard Reference Detergent as described in AATCC Test Method 135. When agreed upon by the purchaser and the supplier a substitute detergent that does not include fabric softener or bleach may be used.

6.10.4 *Equivalent for Drycleaning Specimens*, as described in Test Methods D 2724.

7. Hazards

7.1 Locate the bean bag snag tester in a low-traffic area because of the danger from the exposed rotating cylinders.

7.2 Check that both the plastic disks and the ports are secure by making sure the front disks are flush with the front rims of the cylinders and by hand-tightening the screws that secure the ports.

7.3 Wear protective gloves when examining the pins or removing debris from the cylinders as described in 11.1.

7.4 Observe the following safety precautions when operating the tester: (1) do not wear loose or dangling clothing that can get caught in the pins or moving parts, (2) do not attempt to load or unload the chambers while the cylinders are rotating, and (3) do not injure your hands on the sharp pins when placing specimens in the chambers.

8. Sampling

8.1 *Lot Sample*—As a lot sample for acceptance testing, take at random the number of rolls of fabric directed in an applicable material specification or other agreement between the purchaser and the supplier. Consider rolls of fabric to be the primary sampling units.

8.2 *Laboratory Sample Unit*—As a laboratory sampling unit for acceptance testing, take a full width swatch 1 m or 1 yd long from the end of each roll of fabric in the lot sample, after first discarding the outermost layer of fabric. When laundering and drycleaning tests are to be performed, take additional swatches for the laundering and drycleaning tests.

8.3 *Specimens*—Test three specimens from each swatch. When drycleaning and laundering tests are to be performed, test three additional specimens for drycleaning and three additional specimens for laundering.

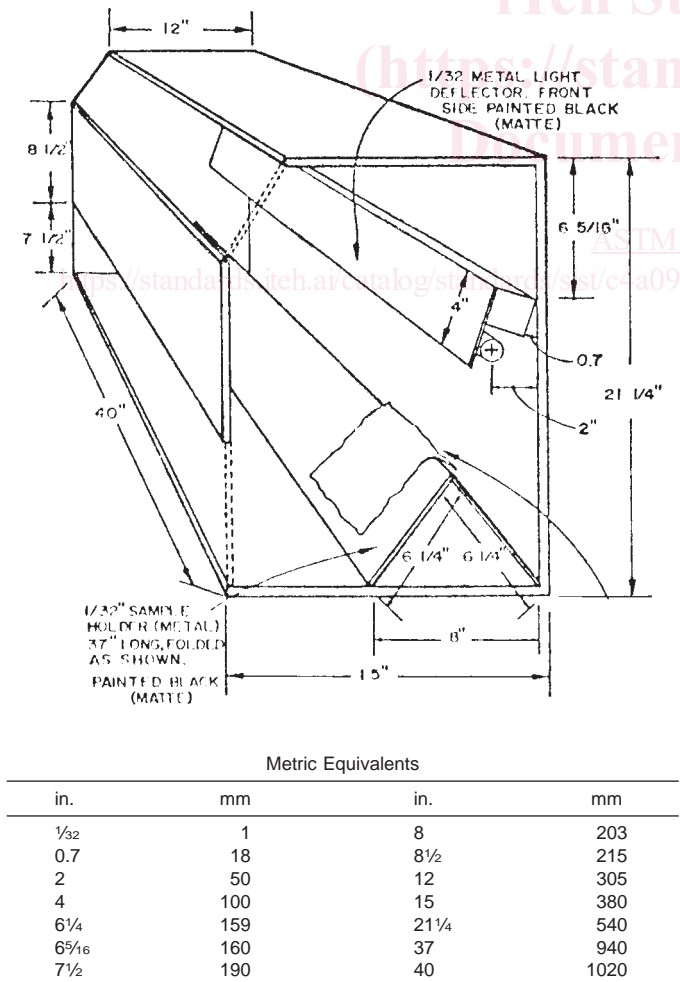

FIG. 5 Apparatus for Fabric Evaluation