



SLOVENSKI STANDARD SIST EN 2997-012:2009

01-maj-2009

5 YfcbUj h_U! ?cbY_lcf jZY_Y_fj b]žc_fc[`]ždf]_`1 Yb]n'bUj c'ba `cVfc _ca ž
cXdcfb]U]bYcXdcfb]dfc]c[b'1 žg'ghUbc'XYcj bc'hYa dYfUti fc'a YX'Ě*) `š7 `]b'%)
š7 žghUbc'&\$ \$ š7 žbUj jý'c' &* \$ š7 '! \$%&"XY. üYgfcVUa U]WU nUdf]fX]hYj in`Ybc
`i _b'c'!'GHUbXUfX'nUdfc]nj cX

Aerospace series - Connectors, electrical, circular, coupled by threaded ring, fire-resistant or non fire-resistant, operating temperatures - 65 °C to 175 °C continuous, 200 °C continuous, 260 °C peak - Part 012: Jam-nut for jam-nut receptacles - Product standard

ITeH STANDARD PREVIEW
(standards.iteh.ai)

Luft- und Raumfahrt - Elektrische Rundsteckverbinder mit Schraubkupplung, feuerbeständig oder nicht feuerbeständig, Betriebstemperaturen - 65 °C bis 175 °C konstant, 200 °C konstant, 260 °C Spitze - Teil 012: Sechskantmutter für festen Steckverbinder, Einlochmontage - Produktnorm

Série aérospatiale - Connecteurs électriques circulaires à accouplement par bague filetée, résistant au feu ou non, températures d'utilisation - 65 °C à 175 °C continu, 200 °C continu, 260 °C en pointe - Partie 012: Écrou pour embase à fixation par écrou - Norme de produit

Ta slovenski standard je istoveten z: EN 2997-012:2009

ICS:

49.060 Š^æ\ æš Ą^•[|b\ æ Aerospace electric
^|\ dā } æ] !^ { æš Ą Ą c { ā equipment and systems

SIST EN 2997-012:2009 en

iTeh STANDARD PREVIEW
(standards.iteh.ai)

SIST EN 2997-012:2009

<https://standards.iteh.ai/catalog/standards/sist/667518e1-aa8c-44f4-bb9d-b7a578456558/sist-en-2997-012-2009>

EUROPEAN STANDARD

EN 2997-012

NORME EUROPÉENNE

EUROPÄISCHE NORM

February 2009

ICS 49.060

English Version

Aerospace series - Connectors, electrical, circular, coupled by threaded ring, fire-resistant or non fire-resistant, operating temperatures - 65 °C to 175 °C continuous, 200 °C continuous, 260 °C peak - Part 012: Jam-nut for jam-nut receptacles - Product standard

Série aérospatiale - Connecteurs électriques circulaires à accouplement par bague filetée, résistant au feu ou non, températures d'utilisation - 65 °C à 175 °C continu, 200 °C continu, 260 °C en pointe - Partie 012: Écrou pour embase à fixation par écrou - Norme de produit

Luft- und Raumfahrt - Elektrische Rundsteckverbinder mit Schraubkupplung, feuerbeständig oder nicht feuerbeständig, Betriebstemperaturen - 65 °C bis 175 °C konstant, 200 °C konstant, 260 °C Spitze - Teil 012: Sechskantmutter für festen Steckverbinder, Einlochmontage - Produktnorm

iTeh STANDARD PREVIEW
(standards.iteh.ai)

This European Standard was approved by CEN on 4 July 2008.

CEN members are bound to comply with the CEN/CENELEC Internal Regulations which stipulate the conditions for giving this European Standard the status of a national standard without any alteration. Up-to-date lists and bibliographical references concerning such national standards may be obtained on application to the CEN Management Centre or to any CEN member.

This European Standard exists in three official versions (English, French, German). A version in any other language made by translation under the responsibility of a CEN member into its own language and notified to the CEN Management Centre has the same status as the official versions.

CEN members are the national standards bodies of Austria, Belgium, Bulgaria, Cyprus, Czech Republic, Denmark, Estonia, Finland, France, Germany, Greece, Hungary, Iceland, Ireland, Italy, Latvia, Lithuania, Luxembourg, Malta, Netherlands, Norway, Poland, Portugal, Romania, Slovakia, Slovenia, Spain, Sweden, Switzerland and United Kingdom.



EUROPEAN COMMITTEE FOR STANDARDIZATION
COMITÉ EUROPÉEN DE NORMALISATION
EUROPÄISCHES KOMITEE FÜR NORMUNG

Management Centre: Avenue Marnix 17, B-1000 Brussels

Contents		Page
1	Scope	4
2	Normative references	4
3	Terms and definitions	4
4	Required characteristics	5
5	Designation	6
6	Marking	6
7	Technical specification	6

iTeh STANDARD PREVIEW
(standards.iteh.ai)

[SIST EN 2997-012:2009](https://standards.iteh.ai/catalog/standards/sist/667518e1-aa8c-44f4-bb9d-b7a578456558/sist-en-2997-012-2009)

<https://standards.iteh.ai/catalog/standards/sist/667518e1-aa8c-44f4-bb9d-b7a578456558/sist-en-2997-012-2009>

Foreword

This document (EN 2997-012:2008) has been prepared by the Aerospace and Defence Industries Association of Europe - Standardization (ASD-STAN).

After enquiries and votes carried out in accordance with the rules of this Association, this Standard has received the approval of the National Associations and the Official Services of the member countries of ASD, prior to its presentation to CEN.

This European Standard shall be given the status of a national standard, either by publication of an identical text or by endorsement, at the latest by August 2009, and conflicting national standards shall be withdrawn at the latest by August 2009.

Attention is drawn to the possibility that some of the elements of this document may be the subject of patent rights. CEN [and/or CENELEC] shall not be held responsible for identifying any or all such patent rights.

According to the CEN/CENELEC Internal Regulations, the national standards organizations of the following countries are bound to implement this European Standard: Austria, Belgium, Bulgaria, Cyprus, Czech Republic, Denmark, Estonia, Finland, France, Germany, Greece, Hungary, Iceland, Ireland, Italy, Latvia, Lithuania, Luxembourg, Malta, Netherlands, Norway, Poland, Portugal, Romania, Slovakia, Slovenia, Spain, Sweden, Switzerland and the United Kingdom.

This standard was reviewed by the Domain Technical Coordinator of ASD-STAN's Electrical Domain.

After inquiries and votes carried out in accordance with the rules of ASD-STAN defined in ASD-STAN's General Process Manual, this standard has received approval for Publication.

<https://standards.iteh.ai/catalog/standards/sist/667518e1-aa8c-44f4-bb9d-b7a578456558/sist-en-2997-012-2009>

EN 2997-012:2009 (E)**1 Scope**

This standard specifies the characteristics of jam-nuts for jam-nut receptacles in the family of circular electrical connectors coupled by threaded ring.

It applies to class defined in Table 2.

For receptacles using these jam-nuts, see EN 2997-004, EN 2997-006 and EN 4067-004, EN 4067-006 for class SE only.

2 Normative references

The following referenced documents are indispensable for the application of this document. For dated references, only the edition cited applies. For undated references, the latest edition of the referenced document (including any amendments) applies.

EN 2997-001, *Aerospace series — Connectors, electrical, circular, coupled by threaded ring, fire-resistant or non fire-resistant, operating temperatures – 65 °C to 175 °C continuous, 200 °C continuous, 260 °C peak — Part 001: Technical specification*

EN 2997-002, *Aerospace series — Connectors, electrical, circular, coupled by threaded ring, fire-resistant or non fire-resistant, operating temperatures – 65 °C to 175 °C continuous, 200 °C continuous, 260 °C peak — Part 002: Specification of performance and contact arrangements*

EN 2997-004, *Aerospace series — Connectors, electrical, circular, coupled by threaded ring, fire-resistant or non fire-resistant, operating temperatures – 65 °C to 175 °C continuous, 200 °C continuous, 260 °C peak — Part 004: Jam-nut mounted receptacle — Product standard*

EN 2997-006, *Aerospace series — Connectors, electrical, circular, coupled by threaded ring, fire-resistant or non fire-resistant, operating temperatures – 65 °C to 175 °C continuous, 200 °C continuous, 260 °C peak — Part 006: Hermetic jam-nut mounted receptacle — Product standard*

EN 4067-002, *Aerospace series — Connectors, electrical, circular, scoop-proof, coupled by threaded ring, fire-resistant, operating temperature 260 °C peak — Part 002: Specification of performance and contacts arrangement*¹⁾

EN 4067-004, *Aerospace series — Connectors, electrical, circular, scoop-proof, coupled by threaded ring, fire-resistant, operating temperature 260 °C peak — Part 004: Jam-nut mounted receptacle — Product standard*¹⁾

EN 4067-006, *Aerospace series — Connectors, electrical, circular, scoop-proof, coupled by threaded ring, fire-resistant, operating temperature 260 °C peak — Part 006: Hermetic jam-nut mounted receptacle — Product standard*¹⁾

ISO 263, *ISO inch screw threads — General plan and selection for screws, bolts and nuts — Diameter range 0,06 to 6 in*

3 Terms and definitions

For the purposes of this document, the terms and definitions given in EN 2997-001 apply.

1) Published as ASD Prestandard at the date of publication of this standard.

4 Required characteristics

4.1 Dimensions

See Figure 1 and Table 1.

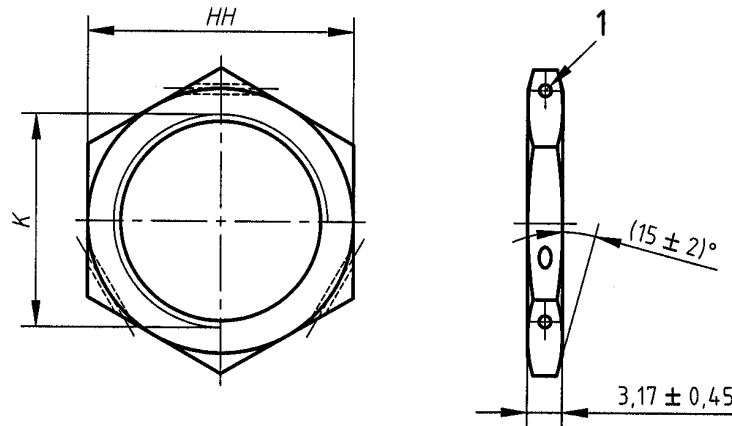

Key

- 1 3 holes \varnothing 1,07 min. equally spaced

Figure 1
Table 1

Housing size	Thread	HH
08	0,6250-25UN	21,06 20,19
10	0,7500-20UNEF	24,23 23,37
12	0,9380-20UNEF	29,01 28,14
14	1,0000-20UNEF	30,61 29,74
16	1,1250-18UNEF	33,76 32,89
18	1,2500-18UNEF	36,96 36,09
20	1,3750-18UNEF	40,11 39,24
22	1,5000-18UNEF	43,31 42,44
24	1,6250-18UNEF	46,46 45,59
28	1,8750-16UNS	54,41 53,54

^a ISO 263.

EN 2997-012:2009 (E)**4.2 Material, surface treatment**

See Table 2.

4.3 Main general characteristics

See EN 2997-002 and EN 4067-002.

5 Designation

EXAMPLE

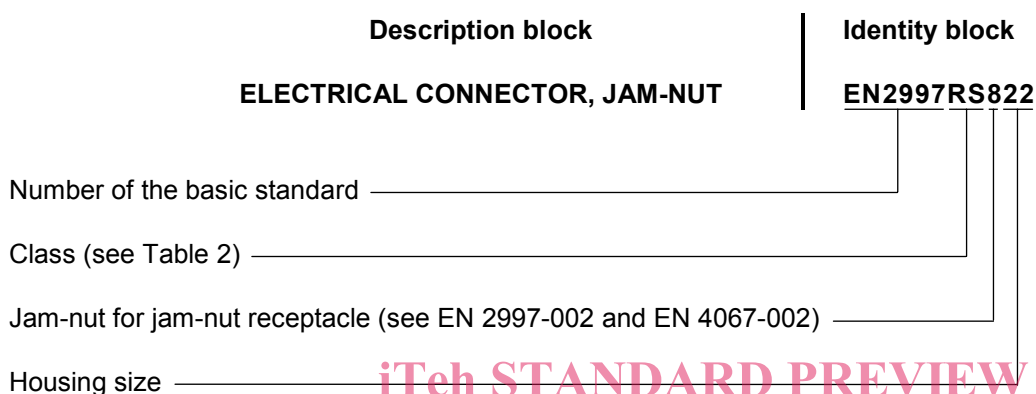

iTeh STANDARD PREVIEW
(standards.iteh.ai)

SIST EN 2997-012:2009
Table 2

<https://standards.iteh.ai/catalog/standards/sist/667518e1-aa8c-44f1-bb9d-b7a578456558/sist-en-2997-012-2009>

Class	Model description
WS	Jam-nut for receptacle with housing (shell) in olive-green, cadmium-plated aluminium alloy, conducting finish, 500 h resistance to salt mist, maximum operating temperature 175 °C continuous.
RS	Jam-nut for receptacle with housing (shell) in nickel-plated aluminium alloy, 48 h resistance to salt mist, maximum operating temperature 200 °C continuous.
SE	Jam-nut for receptacle with housing (shell) in passivated stainless steel, fire-resistant, 500 h resistance to salt mist, maximum operating temperature 260 °C peak. NOTE SE class jam-nut are used for both S, SE, Y and YE classes jam-nut receptacles.

6 Marking

Not applicable.

7 Technical specification

See EN 2997-001.