



SLOVENSKI STANDARD

SIST EN 1917:2003/AC:2008

01-julij-2008

Betonski vstopni in revizijski jaški, nearmirani, z jeklenimi vlakni in armirani

Concrete manholes and inspection chambers, unreinforced, steel fibre and reinforced

Einsteig- und Kontrollschächte aus Beton, Stahlfaserbeton und Stahlbeton

Regards de visite et boîtes de branchement ou d'inspection en béton non armé, béton fibré acier et béton armé

(standards.iteh.ai)

Ta slovenski standard je istoveten z: **EN 1917:2002/AC:2008**

<https://standards.iteh.ai/catalog/standards/sist/dbc46b0-135a-4808-bb9d-2175be8e2be9/sist-en-1917-2003-ac-2008>

ICS:

93.030 Zunanji sistemi za odpadno vodo External sewage systems

SIST EN 1917:2003/AC:2008

en,fr,de

iTeh STANDARD PREVIEW
(standards.iteh.ai)

SIST EN 1917:2003/AC:2008

<https://standards.iteh.ai/catalog/standards/sist/dbcf46b0-135a-4808-bb9d-2175be8e2be9/sist-en-1917-2003-ac-2008>

EUROPEAN STANDARD

EN 1917:2002/AC

NORME EUROPÉENNE

April 2008

EUROPÄISCHE NORM

Avril 2008

April 2008

ICS 93.030

English version
Version Française
Deutsche Fassung

Concrete manholes and inspection chambers, unreinforced, steel fibre and reinforced

Regards de visite et boîtes de branchement
ou d'inspection en béton non armé, béton
fibré acier et béton armé

Einstieg- und Kontrollschächte aus Beton,
Stahlfaserbeton und Stahlbeton

This corrigendum becomes effective on 23 April 2008 for incorporation in the three official language versions of the EN.

Ce corrigendum prendra effet le 23 avril 2008 pour incorporation dans les trois versions linguistiques officielles de la EN.

(standards.iteh.ai)

Die Berichtigung tritt am 23. April 2008 zur Einarbeitung in die drei offiziellen Sprachfassungen der EN in Kraft.

[SIST EN 1917:2003/AC:2008](https://standards.iteh.ai/catalog/standards/sist/dbc46b0-135a-4808-bb9d-2175be8e2be9/sist-en-1917-2003-ac-2008)

<https://standards.iteh.ai/catalog/standards/sist/dbc46b0-135a-4808-bb9d-2175be8e2be9/sist-en-1917-2003-ac-2008>



EUROPEAN COMMITTEE FOR STANDARDIZATION
COMITÉ EUROPÉEN DE NORMALISATION
EUROPÄISCHES KOMITEE FÜR NORMUNG

Management Centre: rue de Stassart, 36 B-1050 Brussels

© 2008 CEN All rights of exploitation in any form and by any means reserved worldwide for CEN national Members.
Tous droits d'exploitation sous quelque forme et de quelque manière que ce soit réservés dans le monde entier aux membres nationaux du CEN.
Alle Rechte der Verwertung, gleich in welcher Form und in welchem Verfahren, sind weltweit den nationalen Mitgliedern von CEN vorbehalten.

Ref. No.: EN 1917:2002/AC:2008 D/E/F

English version

Corrigendum 1

Annex A

Figures A.1a, A.1b and A.2 shall be corrected by replacing the figures along with the above, as follows:

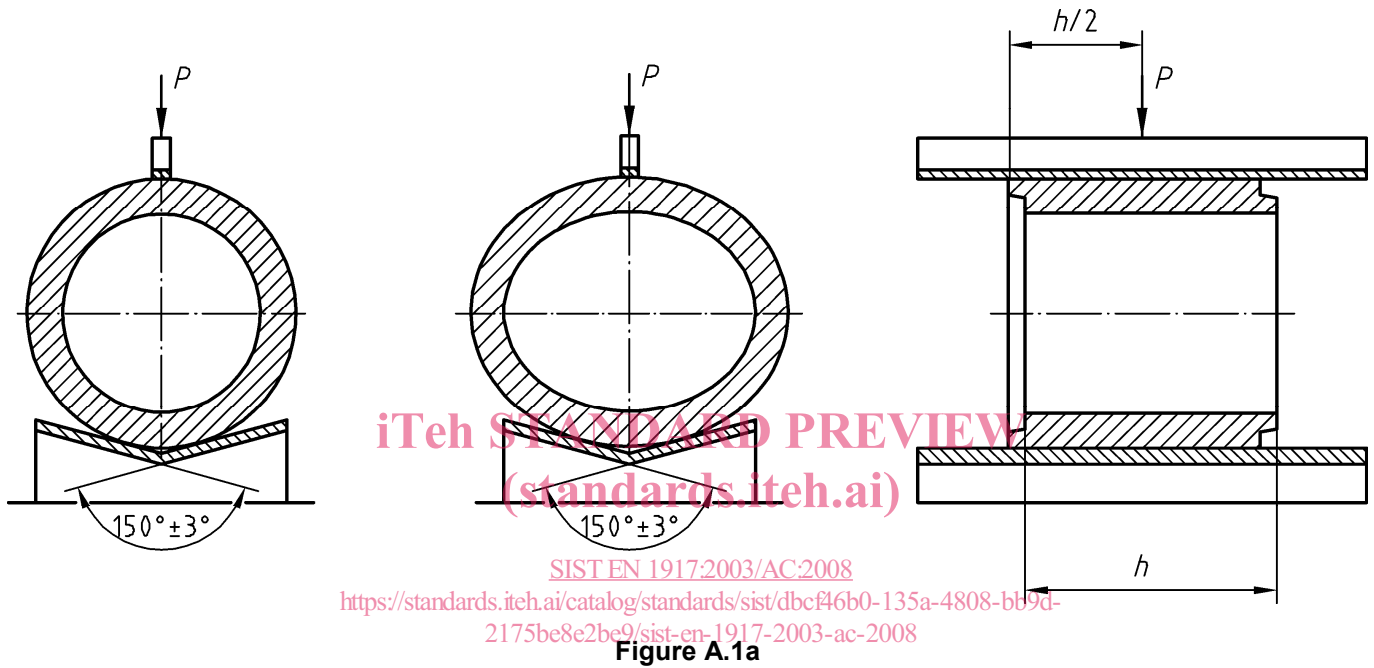

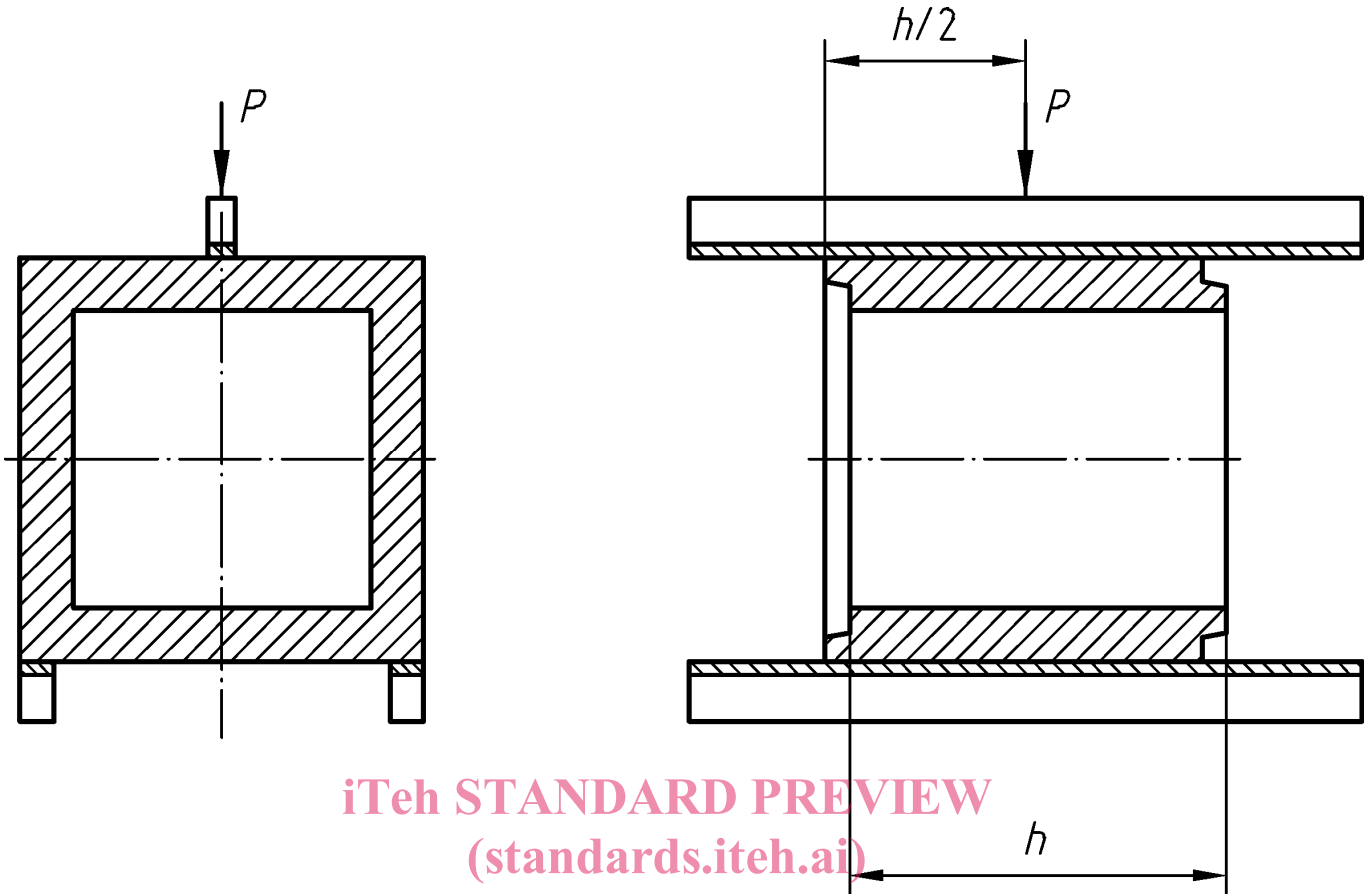

iTeh STANDARD PREVIEW
(standards.iteh.ai)

SIST EN 1917:2002/AC:2008

Figure A.1b

<https://standards.iteh.ai/catalog/standards/sist/dbc46b0-135a-4808-bb9d-c17518e2b204/sist-en-1917-2002-ac-2008>

Figure A.1 — Crushing test on units in a horizontal arrangement

Dimensions in millimetres

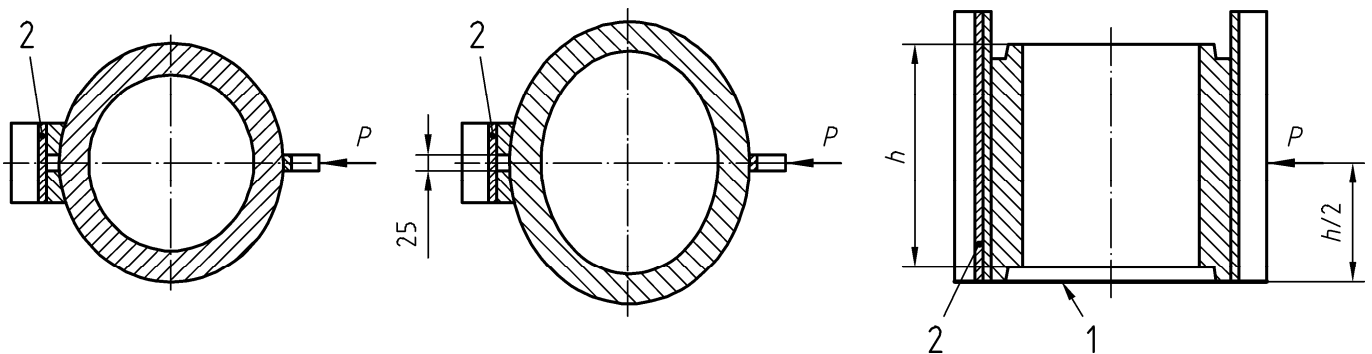

Key

- 1 Sheet material to permit any sliding or removable support
- 2 Low carbon steel facing plate, 330 mm x 25 mm minimum cross-section

Figure A.2 — Crushing test on units in a vertical arrangement

In **Annex J**, Step 8 shall be as follows ("Table H.4" and not "Table H.3"):

Step 8: Determine the acceptability as follows:

Consider the measured value x of the bending tensile stress at the ultimate (collapse) load F_u from the last n consecutive samples.

Calculate the mean value \bar{x} and the standard deviation s of these n values.

Calculate the lower quality statistic Q for the lower specification limit:

$$Q = (\bar{x} - f_{\text{des}})/s$$

where

f_{des} is the lower specification limit for the bending tensile stress,

then compare the quality statistic with the acceptability constant k obtained from the appropriate column in **Table H.4**. Interpolation for intermediate values of n is permissible.

For acceptance, the quality statistic for the lower specification limit shall be greater than or equal to the acceptability constant.

ITeh STANDARD PREVIEW
(standards.iteh.ai)

SIST EN 1917:2003/AC:2008

<https://standards.iteh.ai/catalog/standards/sist/dbc46b0-135a-4808-bb9d-2175be8e2be9/sist-en-1917-2003-ac-2008>

Corrigendum 2

3.1.1 Manhole

Add the following structures to Figure 1 and add "8

Capping unit" to the key:

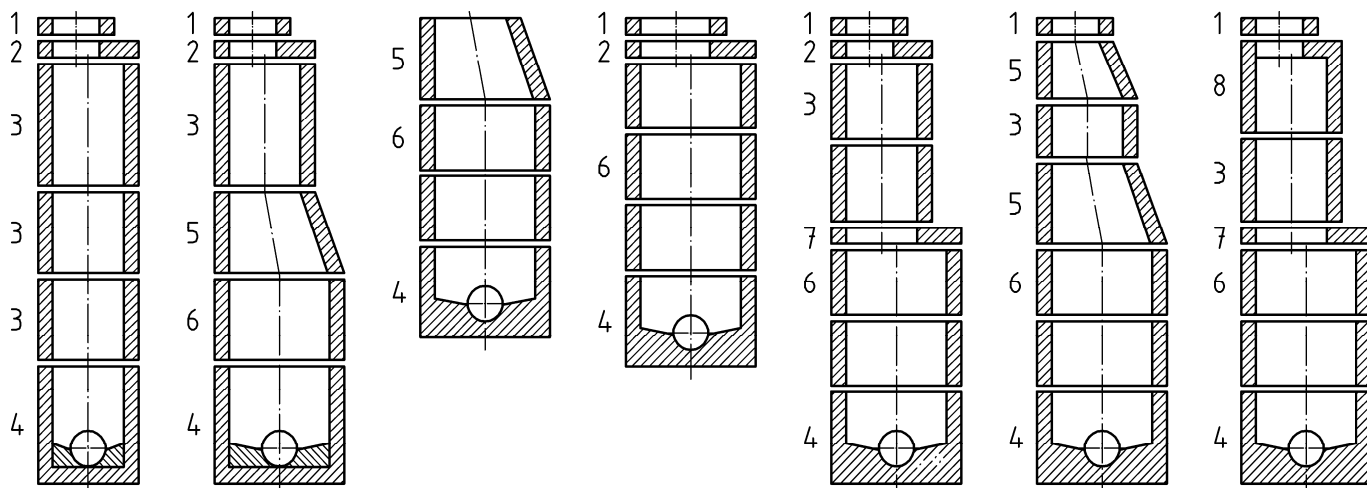

iTeh STANDARD PREVIEW
Figure 1 — Typical structures
(standards.iteh.ai)

Key

- 1 Adjusting unit
- 2 Cover slab
- 3 Shaft unit
- 4 Base unit
- 5 Taper
- 6 Chamber unit
- 7 Reducing slab
- 8 Capping unit**

SIST EN 1917:2003/AC:2008
<https://standards.iteh.ai/catalog/standards/sist/dbc46b0-135a-4808-bb9d-2175be8e2be9/sist-en-1917-2003-ac-2008>

5.2.5 Conformity of proof (crack) load tested units

Add the words "that have been" after "units" in the first sentence:

"Reinforced concrete units **that have been** tested only to proof (crack) load in accordance with 6.4 or 6.5 and meeting the requirements of 5.2.3 or 5.2.4 as appropriate conform to this European Standard."

6.1 General

Footnote a shall be changed as follows:

Table 5 — Summary of test requirements

Clause	Requirement where specified	Vertical units			Cover slabs, reducing slabs and tapers (reducing units)	Adjusting units
		Chamber and shaft units	Base units	Capping units		
4.2.2.1	Drilled core strength ^a	-	T/R	T/R	T/R ^b	T/R
^a means only applicable to units whose conformity is not specified in this European Standard to be verified by routine performance testing, including the walls of capping units						

6.8 Concrete strength in base units, capping unit walls, adjusting units and certain tapers

Correct the conversion factor for drilled 50 mm ± 1 mm diameter cores from 0,9 into 1,07:

"Tests shall be carried out on drilled cores with a height equal to their diameter ± 10 mm:

- when 100 mm ± 1 mm diameter cores are used, the result shall be applied without any conversion factor;
- when 50 mm ± 1 mm diameter cores are used, a conversion factor of **1,07** shall be applied to the results."

iTech STANDARD PREVIEW
(standards.iteh.ai)

Annex B: B.2 Apparatus

Add requirements on application of test load and accuracy of testing machine in accordance with those that apply for the crushing test on chamber and shaft units and specify the dimensions of the steel or cast iron plates. Replace the first sentence as follows:

"The apparatus shall consist of a testing machine capable of applying the full test load without shock or impact and with an accuracy of 3 % of the specified test load. The apparatus shall be equipped with steel or cast iron plates, through which the specified load is applied to the unit whilst it is supported around its perimeter. The dimensions of the steel or cast iron plate shall not exceed more than 125 mm the dimensions of the access opening. The width of beddings in contact with the unit shall correspond to the conditions that would be achieved in the structure for which the unit was designed."

Annex B: B.4.2 Reinforced concrete units

Replace the plan views of Figures B.1 and B.2 by the following:

Dimensions in millimetres

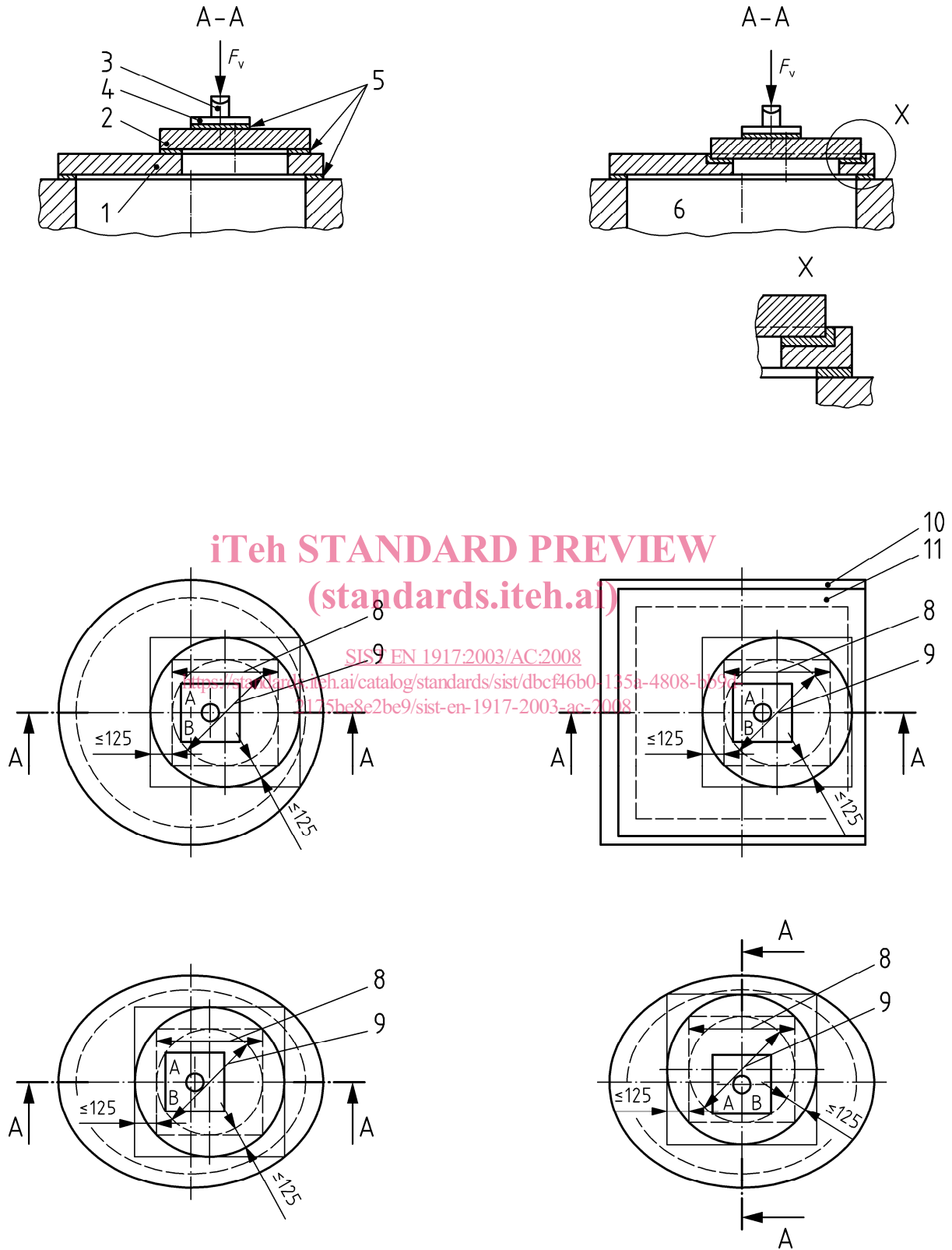
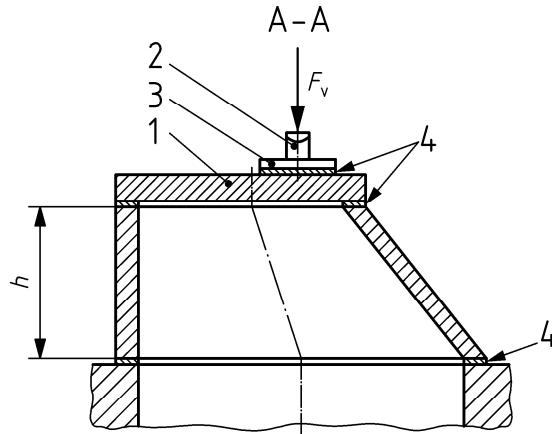

Figure B.1 — Vertical strength test for capping units, cover slabs and reducing slabs



iTeh STANDARD PREVIEW
(standards.iteh.ai)

https://standards.iteh.ai/catalog/standards/sist/dbcf46b0-135a-4808-bb9d-175be8e2be9/sist-en-1917-2003-ac-2008

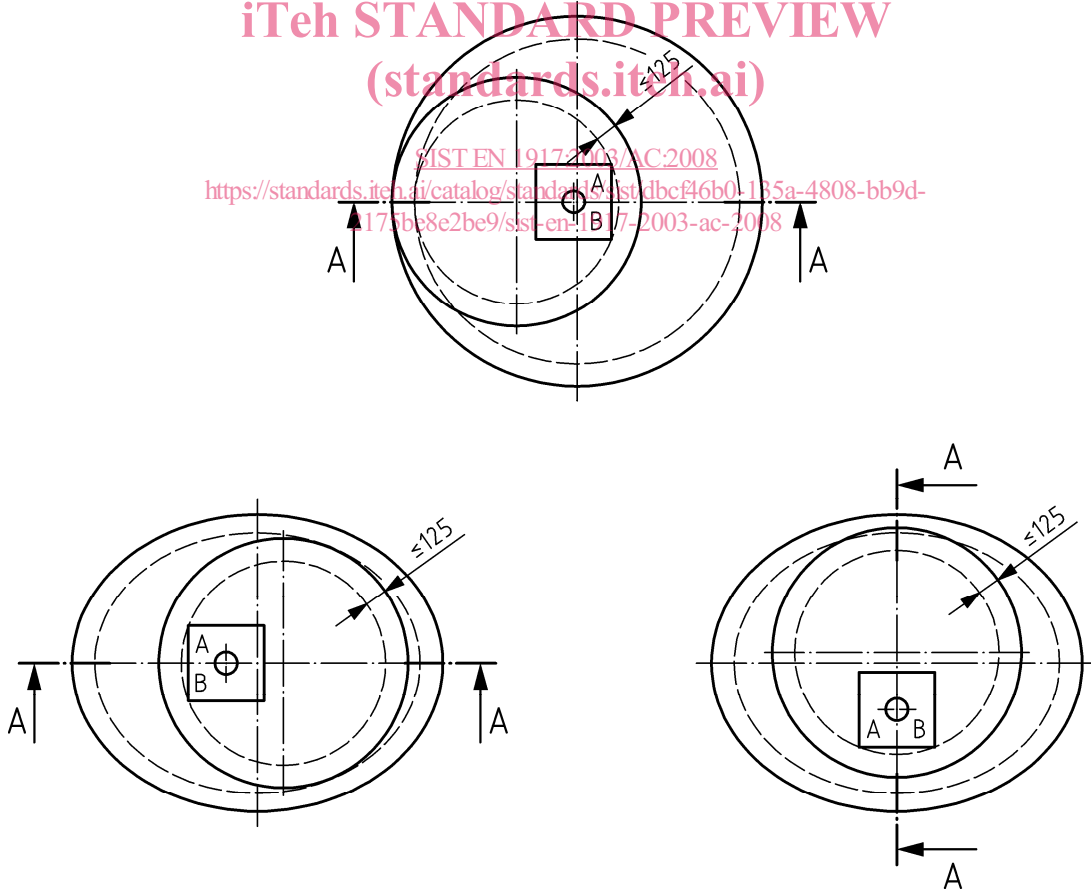

Figure B.2 — Vertical strength test for certain tapers

Annex C: C.7.2 Watertightness during angular deflection

Clarify the procedure for preventing the joint gap from closing by deleting the word "mean" in the 3rd sentence:

"The connecting pipe(s) or adaptor(s) shall be deflected to an angular deflection of 12 500/DN (or 12 500/WN, as appropriate to the shape of the bore of the connecting pipe(s) or adaptor(s)) in millimetres per metre or 50 millimetres per metre, whichever is the smaller, taking care to ensure that no structural damage is caused. In the case of an egg-shaped connecting pipe or adaptor the deflection shall be in the vertical plane. During this operation the joint gap(s) shall be prevented from closing at any point by, for example, interposing at the appropriate place(s) a packing with a thickness equal to the [] value of the clearance stated in the factory documents."

Annex C: C.7.3: Watertightness under shear load

Take into account that the pipe submitted to the watertightness test is not necessary completely filled with water: Add after the formula for R_s and the definition of W_w :

"Where the pipe is completely filled with water the value of R_s shall be calculated according to the following formula:

$$R_s = (F_s - W_w / 2) \times l_1 / (l_1 - a_s) \geq 0, \text{ in kilonewtons}$$

where

W_w is the weight of one unit filled with water, in kilonewtons

Where the full length of the pipe barrel is not filled with water the formula shall be adjusted accordingly."

SIST EN 1917:2003/AC:2008

[https://standards.iteh.ai/catalog/standards/sist/dbc46b0-135a-4808-bb9d-](https://standards.iteh.ai/catalog/standards/sist/dbc46b0-135a-4808-bb9d-2175be8e2be9/sist-en-1917-2003-ac-2008)

[2175be8e2be9/sist-en-1917-2003-ac-2008](https://standards.iteh.ai/catalog/standards/sist/dbc46b0-135a-4808-bb9d-2175be8e2be9/sist-en-1917-2003-ac-2008)

Annex D: D.4.1 Determination of mass of immersed sample m_1

Clarify the procedure of immersing the sample, by inserting the word "minimum" to the 2nd sentence:

"The sample shall be brought to a temperature of 20 °C ± 3 °C, then immersed in tap water at the same temperature until a constant mass has been reached. This shall be achieved in stages by successively immersing the sample at intervals of one hour to approximately 1/3 of the height, approximately 2/3 of the height and the total height, with a **minimum** final water level of 20 mm above the top surface of the sample."

Annex G: Table G.1 :

Correct sampling procedures for concrete cover according to clauses 5.2.2:

- by replacing the frequency 1 N for the initial type test by 1 S;
- by adding the word "using" before "covermeter" for the initial type test;
- by replacing the reference to 5.2.3 and 5.2.4 by the word "collapse" for the routine inspection."

Table G.1 — Sampling procedures

Clause	Test when specified	Initial type test	Routine inspection
5.2.2	Concrete cover	1 S using every unit that has been type-tested to 5.2.3 or 5.2.4, or using covermeter for other units	Every unit that has been tested to collapse and, using covermeter, 2 N/day

Annex H: H.4: Figure H.1

Correct symbol for the standard deviation in the last lozenge of the right branch of the flow chart ($\delta \rightarrow \sigma$).

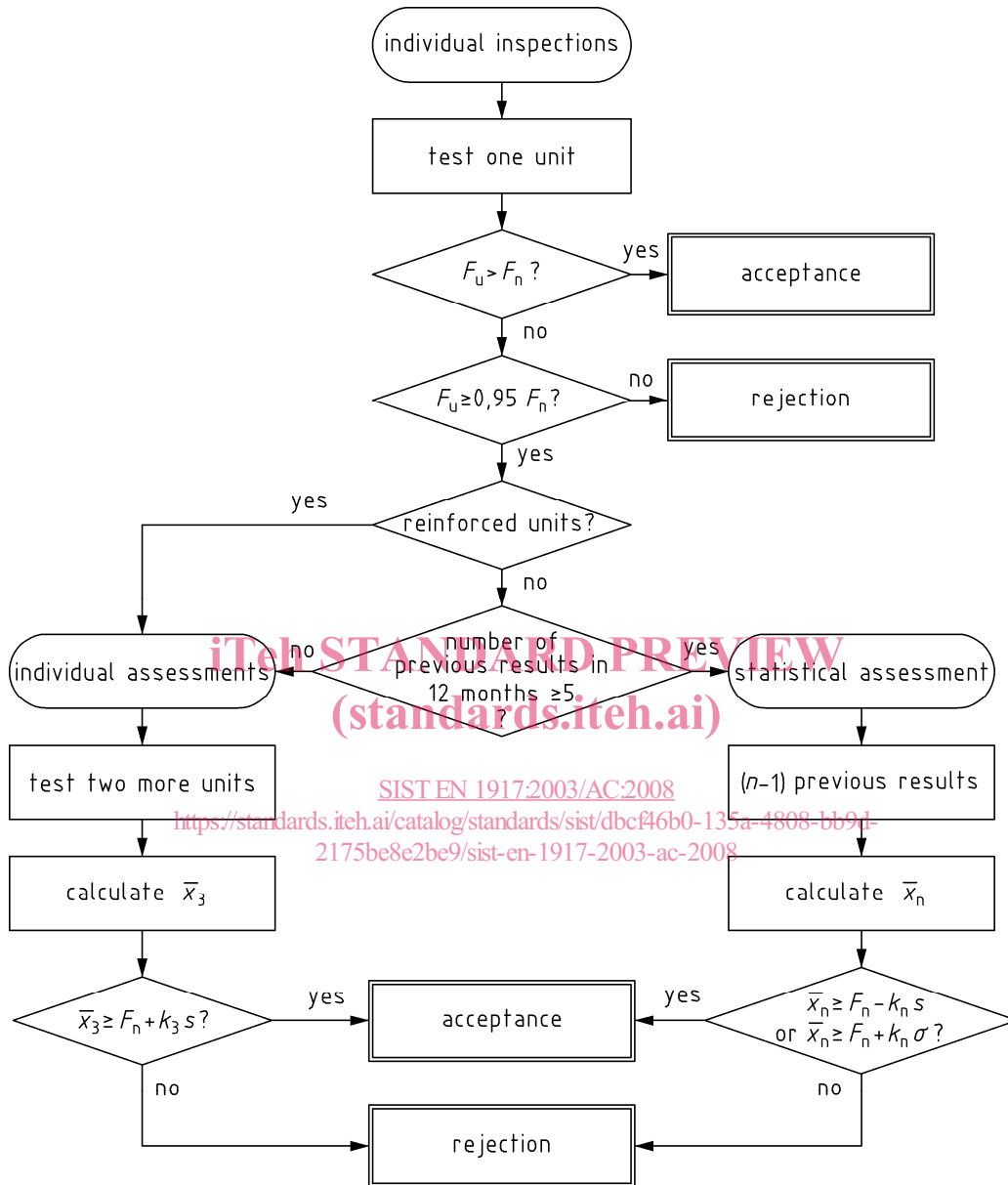

Figure H.1 — Flow chart for inspection of ultimate (collapse) load on the basis of individual assessments (excluding inspection of unreinforced units using the Annex J option and basic inspection of reinforced units)