**Paints and varnishes — Rapid-deformation
(impact resistance) tests —**

**Part 1:
Falling-weight test, large-area indenter**

*Peintures et vernis — Essais de déformation rapide (résistance au choc) —
Partie 1: Essai de chute d'une masse avec pénétrateur de surface
importante*

ISO 6272-1:2002

<https://standards.iteh.ai/catalog/standards/sist/12b6381d-c25b-4662-b2cb-138bfe743621/iso-6272-1-2002>



PDF disclaimer

This PDF file may contain embedded typefaces. In accordance with Adobe's licensing policy, this file may be printed or viewed but shall not be edited unless the typefaces which are embedded are licensed to and installed on the computer performing the editing. In downloading this file, parties accept therein the responsibility of not infringing Adobe's licensing policy. The ISO Central Secretariat accepts no liability in this area.

Adobe is a trademark of Adobe Systems Incorporated.

Details of the software products used to create this PDF file can be found in the General Info relative to the file; the PDF-creation parameters were optimized for printing. Every care has been taken to ensure that the file is suitable for use by ISO member bodies. In the unlikely event that a problem relating to it is found, please inform the Central Secretariat at the address given below.

iTeh STANDARD PREVIEW
(standards.iteh.ai)

ISO 6272-1:2002

<https://standards.iteh.ai/catalog/standards/sist/12b6381d-c25b-4662-b2cb-138bf743621/iso-6272-1-2002>

© ISO 2002

All rights reserved. Unless otherwise specified, no part of this publication may be reproduced or utilized in any form or by any means, electronic or mechanical, including photocopying and microfilm, without permission in writing from either ISO at the address below or ISO's member body in the country of the requester.

ISO copyright office
Case postale 56 • CH-1211 Geneva 20
Tel. + 41 22 749 01 11
Fax + 41 22 749 09 47
E-mail copyright@iso.ch
Web www.iso.ch

Printed in Switzerland

Contents

	Page
1 Scope	1
2 Normative references	1
3 Required supplementary information	2
4 Apparatus	2
5 Sampling	2
6 Test panels	4
7 Procedure	5
8 Precision	6
9 Test report	6
Annex	
A Required supplementary information	7

iTeh STANDARD PREVIEW
(standards.iteh.ai)

ISO 6272-1:2002

<https://standards.iteh.ai/catalog/standards/sist/12b6381d-c25b-4662-b2cb-138bf743621/iso-6272-1-2002>

Foreword

ISO (the International Organization for Standardization) is a worldwide federation of national standards bodies (ISO member bodies). The work of preparing International Standards is normally carried out through ISO technical committees. Each member body interested in a subject for which a technical committee has been established has the right to be represented on that committee. International organizations, governmental and non-governmental, in liaison with ISO, also take part in the work. ISO collaborates closely with the International Electrotechnical Commission (IEC) on all matters of electrotechnical standardization.

International Standards are drafted in accordance with the rules given in the ISO/IEC Directives, Part 3.

Draft International Standards adopted by the technical committees are circulated to the member bodies for voting. Publication as an International Standard requires approval by at least 75 % of the member bodies casting a vote.

Attention is drawn to the possibility that some of the elements of this part of ISO 6272 may be the subject of patent rights. ISO shall not be held responsible for identifying any or all such patent rights.

International Standard ISO 6272-1 was prepared by Technical Committee ISO/TC 35, *Paints and varnishes*, Subcommittee SC 9, *General test methods for paints and varnishes*.

Together with ISO 6272-2, this part of ISO 6272 cancels and replaces ISO 6272:1993. The main change is the introduction of the option to increase the mass of the weight that is dropped onto the panel, thus enabling a more severe test to be carried out.

ISO 6272 consists of the following parts, under the general title *Paints and varnishes — Rapid-deformation (impact resistance) tests*:

- *Part 1: Falling-weight test, large-area indenter*
- *Part 2: Falling-weight test, small-area indenter*

Annex A forms a normative part of this part of ISO 6272.

Paints and varnishes — Rapid-deformation (impact resistance) tests —

Part 1: Falling-weight test, large-area indenter

WARNING — This part of ISO 6272 does not purport to address the all of the safety problems, if any, associated with its use. It is the responsibility of the user of this part of ISO 6272 to establish appropriate safety and health practices and determine the applicability of regulatory limitations prior to use.

1 Scope

This part of ISO 6272 describes a method for evaluating the resistance of a dry film of paint, varnish or related product to cracking or peeling from a substrate when it is subjected to a deformation caused by a falling weight, with a 20-mm-diameter spherical indenter, dropped under standard conditions.

NOTE The term “impact resistance” is included in the title of this part of ISO 6272, but one important characteristic of the apparatus used is that it should produce rapid deformation rather than a true impact.

The method described can be applied

- either as a pass/fail test, the test being carried out from one drop height and with a specified mass, so as to test compliance with a particular specification;
- or as a classification test, to determine the minimum mass and/or drop height for which the coating cracks or peels from its substrate by gradually increasing the drop height and/or the mass.

2 Normative references

The following normative documents contain provisions which, through reference in this text, constitute provisions of this part of ISO 6272. For dated references, subsequent amendments to, or revisions of, any of these publications do not apply. However, parties to agreements based on this part of ISO 6272 are encouraged to investigate the possibility of applying the most recent editions of the normative documents indicated below. For undated references, the latest edition of the normative document referred to applies. Members of ISO and IEC maintain registers of currently valid International Standards.

ISO 1513, *Paints and varnishes — Examination and preparation of samples for testing*

ISO 1514, *Paints and varnishes — Standard panels for testing*

ISO 2808, *Paints and varnishes — Determination of film thickness*

ISO 3270, *Paints and varnishes and their raw materials — Temperatures and humidities for conditioning and testing*

ISO 15528, *Paints, varnishes and raw materials for paints and varnishes — Sampling*

3 Required supplementary information

For any particular application, the test method specified in this part of ISO 6272 needs to be completed by supplementary information. The items of supplementary information are given in annex A.

4 Apparatus

Ordinary laboratory apparatus and glassware, together with the following:

4.1 Falling-weight apparatus, comprising the elements described in 4.1.1 to 4.1.7.

4.1.1 Base stand, of sufficient mass to support the die (4.1.5).

4.1.2 Primary falling weight (see Figure 1), the head having the shape of a spherical segment of diameter $(20 \pm 0,3)$ mm, and a total mass of $(1\ 000 \pm 1)$ g.

4.1.3 Secondary weight(s), which may be added to the primary falling weight in order to increase the severity of the test. The mass of each weight may be $(1\ 000 \pm 1)$ g or $(2\ 000 \pm 2)$ g, and the total load may be 1 kg, 2 kg, 3 kg or 4 kg.

4.1.4 Vertical guide tube (see Figures 1 and 2), to direct the primary falling weight (4.1.2) perpendicularly on to the test panel. The guide tube shall be graduated in millimetres to indicate the distance above the surface of the test panel.

To avoid excessive friction and to ensure accurate guidance, the difference between the inner radius of the guide tube and the outer radius of the falling weight shall be $(0,7 \pm 0,1)$ mm and the distance between the bottom end of the guide tube and the top of the test panel shall be not more than 45 mm.

4.1.5 Die (see Figure 1), ring-shaped with an inner diameter of $(27 \pm 0,3)$ mm. The inner upper edge of the ring shall be rounded, with a radius of curvature of $(0,9 \pm 0,2)$ mm. The minimum height of the ring shall be 20 mm.

4.1.6 Clamping sleeve (see Figures 1 and 2), to hold the test panel in position. The inner diameter at the bottom shall be the same as that of the die [$(27 \pm 0,3)$ mm], however it is important to ensure that the head of the primary weight can travel smoothly through the clamping sleeve.

4.1.7 Stops (see Figure 2), of different thicknesses, to limit the indentation depth of the falling weight.

4.2 Viewing lens, hand-held, with a magnification of $\times 10$.

5 Sampling

Take a representative sample of the coating material to be tested (or of each product in the case of a multi-coat system), as described in ISO 15528.

Examine and prepare each sample for testing, as described in ISO 1513.

Dimensions in millimetres

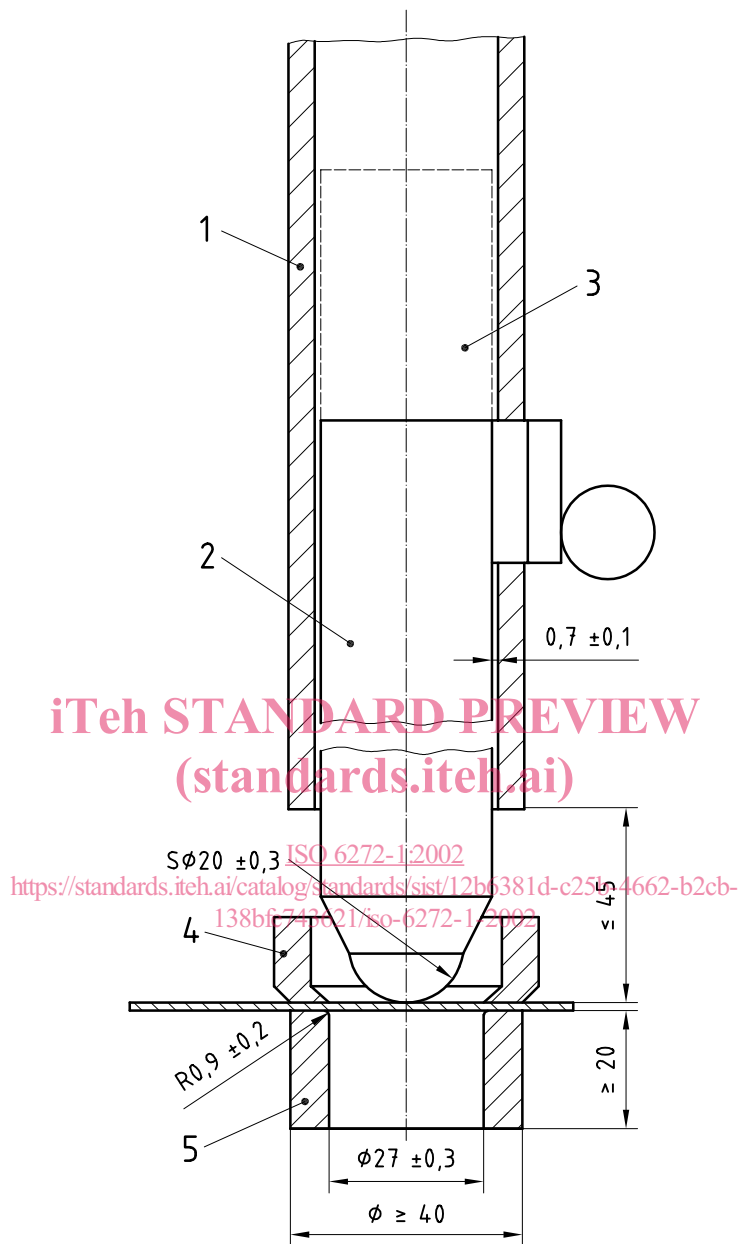

Key

- 1 Guide tube
- 2 Primary weight
- 3 Secondary weight(s)
- 4 Clamping sleeve
- 5 Die

Figure 1 — Falling-weight apparatus showing required dimensions

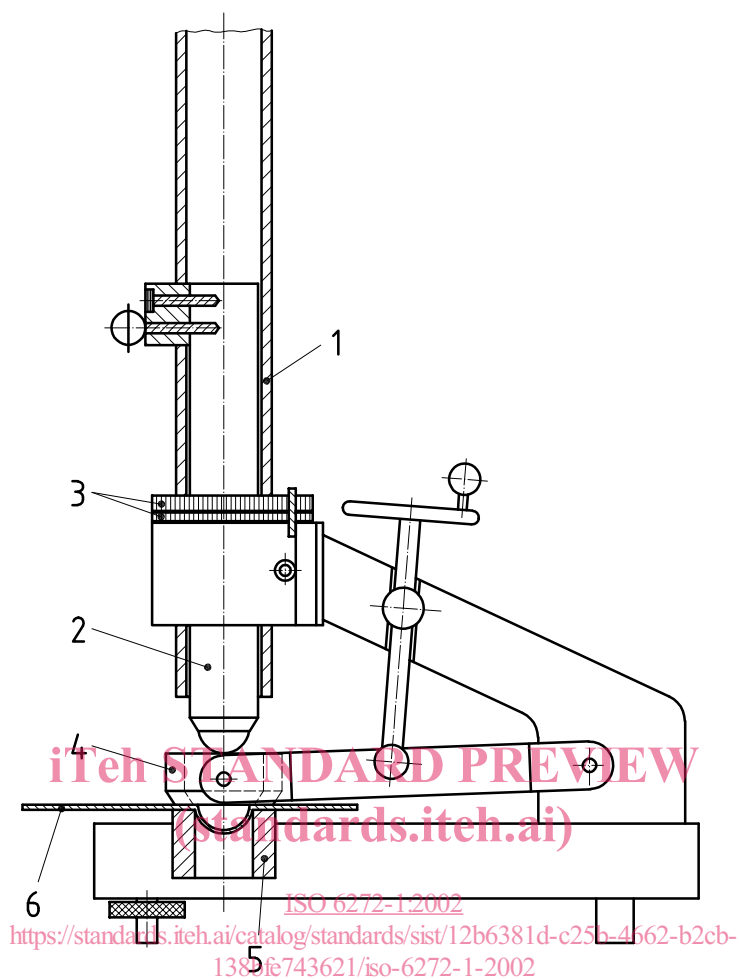

Key

1	Guide tube
2	Falling weight
3	Stops
4	Clamping sleeve
5	Die
6	Test panel

Figure 2 — Side view of falling-weight apparatus

6 Test panels

6.1 Substrate

Unless otherwise agreed, the substrate shall be metal, conforming with the requirements of ISO 1514.

The panels shall be planar, free from distortion and at least 0,25 mm thick. The dimensions shall be such as to allow the test to be carried out at at least five different positions not less than 40 mm from each other and not less than 20 mm from the edge of the panel.

Measure the thickness to the nearest 0,01 mm.

6.2 Preparation and coating

Unless otherwise agreed, prepare each test panel in accordance with ISO 1514 and then coat it by the specified method with the product or system under test.

6.3 Drying

Dry (or stove) and age (if applicable) each coated test panel for the specified time and under the specified conditions.

6.4 Thickness of coating

Determine the thickness, in micrometres, of the dried coating by one of the procedures specified in ISO 2808. Make the measurements at, or as near as possible to, the positions at which the test is to be carried out.

Use only test panels for which the film thickness values do not differ from the specified or agreed film thickness by more than 10 %.

7 Procedure

7.1 General

Unless otherwise specified, immediately prior to the test condition the panels at a temperature of $(23 \pm 2) ^\circ\text{C}$ and a relative humidity of $(50 \pm 5) \%$ for at least 16 h.

Mount the apparatus on a firm surface (for example, concrete, steel or stone).

Carry out the test at $(23 \pm 2) ^\circ\text{C}$ and a relative humidity of $(50 \pm 5) \%$, unless otherwise agreed (see also ISO 3270).

<https://standards.iteh.ai/catalog/standards/sist/12b6381d-c25b-4662-b2cb-138bf743621/iso-6272-1-2002>

7.2 Pass/fail test (using a specified mass)

Ensure that the guide tube (4.1.4) is vertical. Attach the secondary weight(s), if required, to the primary weight in order to achieve the required loading.

Adjust the height of the weight to the required release-point (using the graduations on the guide tube) and lock in position. If necessary, fit stop(s) (4.1.7) of total thickness sufficient to limit the indentation to a depth agreed between the interested parties or as otherwise specified. Place a test panel (see clause 6) on the die (4.1.5), with the coated face up or down, as specified [see annex A, item h)]. Hold the test panel in position by means of the clamping sleeve. Release the weight (4.1.2) and allow it to fall on to the test panel.

Examine the coating with the lens (4.2).

Report whether the coating on the test panel has cracked or has peeled from the substrate and whether or not the substrate has cracked.

Repeat the test a further four times at different positions, giving a total of five drops. Report the coating as satisfactory if at least four test positions show no cracking or peeling from the substrate.

7.3 Classification test (to determine the minimum drop height and mass which will cause cracking or peeling)

7.3.1 Ensure that the guide tube (4.1.4) is vertical. Adjust the height of the primary weight (4.1.2) to the position where it is expected that no failure will occur and lock in position. Place a test panel (see clause 6) on the die (4.1.5), with the coated face up or down, as specified [see annex A, item h)]. Hold the test panel in position by means of the clamping sleeve. Release the weight (4.1.2) and allow it to fall on to the test panel.