

Second edition
2001-10-15

Corrected version
2007-02-01

**Plastics — Vinyl chloride homopolymer and
copolymer resins — Sieve analysis using
air-jet sieve apparatus**

*Plastiques — Résines d'homopolymères et copolymères de chlorure de
vinyle — Analyse granulométrique sur tamiseuse à dépression d'air*

iTeh STANDARD PREVIEW
(standards.iteh.ai)

[ISO 4610:2001](https://standards.iteh.ai/catalog/standards/sist/ec0758c6-a353-46cb-99e8-7468b15f4a2b/iso-4610-2001)

[https://standards.iteh.ai/catalog/standards/sist/ec0758c6-a353-46cb-99e8-
7468b15f4a2b/iso-4610-2001](https://standards.iteh.ai/catalog/standards/sist/ec0758c6-a353-46cb-99e8-7468b15f4a2b/iso-4610-2001)



Reference number
ISO 4610:2001(E)

© ISO 2001

PDF disclaimer

This PDF file may contain embedded typefaces. In accordance with Adobe's licensing policy, this file may be printed or viewed but shall not be edited unless the typefaces which are embedded are licensed to and installed on the computer performing the editing. In downloading this file, parties accept therein the responsibility of not infringing Adobe's licensing policy. The ISO Central Secretariat accepts no liability in this area.

Adobe is a trademark of Adobe Systems Incorporated.

Details of the software products used to create this PDF file can be found in the General Info relative to the file; the PDF-creation parameters were optimized for printing. Every care has been taken to ensure that the file is suitable for use by ISO member bodies. In the unlikely event that a problem relating to it is found, please inform the Central Secretariat at the address given below.

iTeh STANDARD PREVIEW
(standards.iteh.ai)

ISO 4610:2001

<https://standards.iteh.ai/catalog/standards/sist/ec0758c6-a353-46cb-99e8-7468b15f4a2b/iso-4610-2001>

© ISO 2001

All rights reserved. Unless otherwise specified, no part of this publication may be reproduced or utilized in any form or by any means, electronic or mechanical, including photocopying and microfilm, without permission in writing from either ISO at the address below or ISO's member body in the country of the requester.

ISO copyright office
Case postale 56 • CH-1211 Geneva 20
Tel. + 41 22 749 01 11
Fax + 41 22 749 09 47
E-mail copyright@iso.ch
Web www.iso.ch

Printed in Switzerland

Contents

	Page
1 Scope	1
2 Normative reference	1
3 Term and definition	1
4 Sampling	1
5 Sample preparation	1
6 Apparatus	2
7 Procedure	3
8 Expression of results	3
9 Precision	4
10 Test report	4

iTeh STANDARD PREVIEW
(standards.iteh.ai)

[ISO 4610:2001](https://standards.iteh.ai/catalog/standards/sist/ec0758c6-a353-46cb-99e8-7468b15f4a2b/iso-4610-2001)

<https://standards.iteh.ai/catalog/standards/sist/ec0758c6-a353-46cb-99e8-7468b15f4a2b/iso-4610-2001>

Foreword

ISO (the International Organization for Standardization) is a worldwide federation of national standards bodies (ISO member bodies). The work of preparing International Standards is normally carried out through ISO technical committees. Each member body interested in a subject for which a technical committee has been established has the right to be represented on that committee. International organizations, governmental and non-governmental, in liaison with ISO, also take part in the work. ISO collaborates closely with the International Electrotechnical Commission (IEC) on all matters of electrotechnical standardization.

International Standards are drafted in accordance with the rules given in the ISO/IEC Directives, Part 3.

Draft International Standards adopted by the technical committees are circulated to the member bodies for voting. Publication as an International Standard requires approval by at least 75 % of the member bodies casting a vote.

Attention is drawn to the possibility that some of the elements of this International Standard may be the subject of patent rights. ISO shall not be held responsible for identifying any or all such patent rights.

International Standard ISO 4610 was prepared by Technical Committee ISO/TC 61, *Plastics*, Subcommittee SC 9, *Thermoplastic materials*.

This second edition cancels and replaces the first edition (ISO 4610:1977), which has been modified as follows:

- emulsion-polymerized PVC has been included in the scope;
- a second obligatory measurement has been included;
- a precision statement, based on current test data, has been included.

In this corrected version of ISO 4610:2001, the URL in Clause 9 has been replaced by a more user-friendly one.

Plastics — Vinyl chloride homopolymer and copolymer resins — Sieve analysis using air-jet sieve apparatus

1 Scope

This International Standard specifies a method for the determination of the sieve retention and particle size distribution of preferably free-flowing vinyl chloride homopolymer and copolymer resins prepared by the “suspension”, “bulk” and “emulsion” polymerization processes. Control of these characteristics can help to ensure consistency of supply and predictable processing behaviour.

2 Normative reference

The following normative document contains provisions which, through reference in this text, constitute provisions of this International Standard. For dated references, subsequent amendments to, or revisions of, any of these publications do not apply. However, parties to agreements based on this International Standard are encouraged to investigate the possibility of applying the most recent edition of the normative document indicated below. For undated references, the latest edition of the normative document referred to applies. Members of ISO and IEC maintain registers of currently valid International Standards.

ISO 565, *Test sieves — Metal wire cloth, perforated metal plate and electroformed sheet — Nominal sizes of openings*

ISO 4610:2001

<https://standards.iteh.ai/catalog/standards/sist/cc0758c6-a353-46cb-99e8-7468b15f4a2b/iso-4610-2001>

3 Term and definition

For the purposes of this International Standard, the following term and definition applies.

3.1

sieve retention

the percentage of the mass of resin remaining on the sieve after the test

4 Sampling

Take a sample which is representative of the resin as delivered and of sufficient size to permit the determination of the size distribution.

Generally, 25 g shall be used for each sieve analysis. For fine-particle resins, which for the purpose of this International Standard are defined as between 80 μm and 100 μm , smaller quantities are more convenient, for example 10 g.

5 Sample preparation

Unless otherwise agreed, analyse the sample as received (i.e. as delivered).

If the sample is not analysed on the day of receipt, it shall be kept in a sealed container under ambient conditions.

To prevent difficulty in sieving caused by electrostatic charging of the resin, add an antistatic agent, for example 0,5 % by mass of γ -alumina, unless otherwise specified, to the resin at the start of the analysis.

6 Apparatus

6.1 Sieves, circular, having a sieving surface corresponding to a diameter of 200 mm. The sides and mesh of each sieve shall be made of metal. The mesh shall be as defined in ISO 565. The choice of mesh aperture depends on the requirements and the particle size distribution of the resin to be examined.

NOTE A suitable method of cleaning sieves is to use an ultrasonic cleaning device containing water and a detergent.

6.2 Air-jet sieve apparatus (see Figure 1), consisting of a casing designed to contain a sieve (6.1), in the lower part of which are an outlet, to which suction may be applied, and an air inlet. The casing shall be covered with a preferably transparent lid.

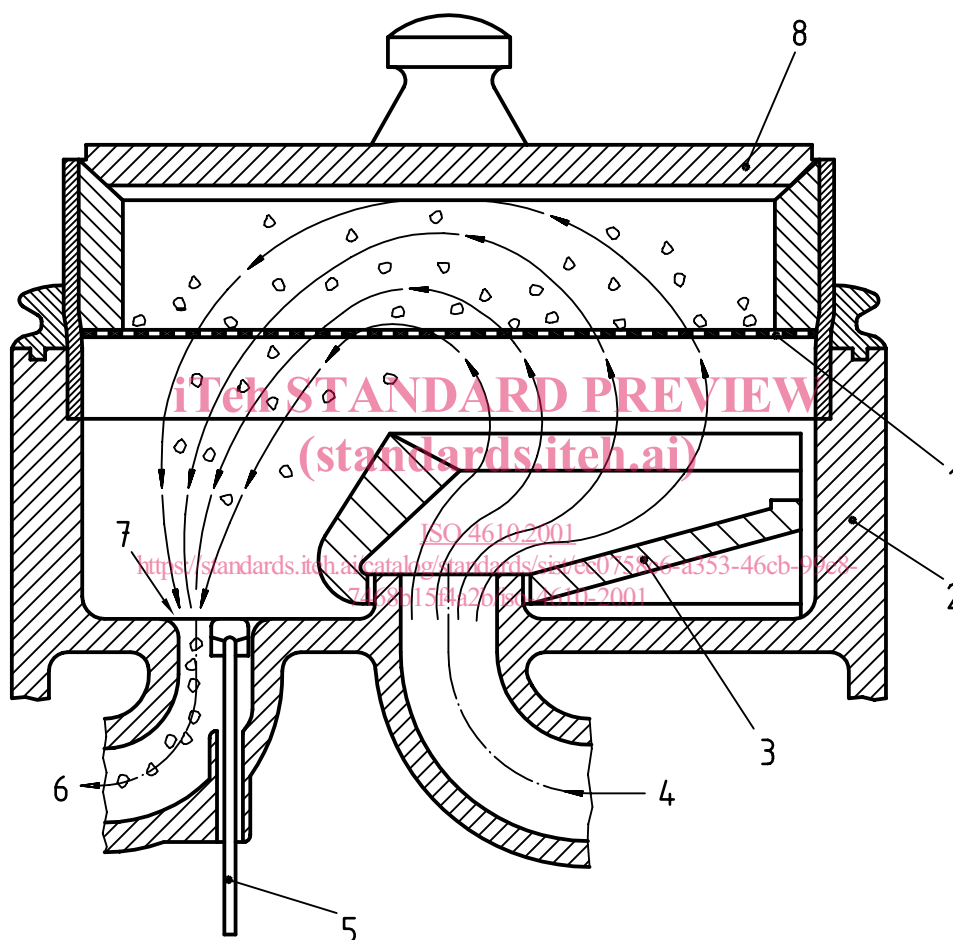

Key

- 1 Sieve
- 2 Casing
- 3 Rotating jet
- 4 Air inlet
- 5 Manometer
- 6 To vacuum
- 7 Adjustable slot
- 8 Lid (preferably transparent)

Figure 1 — Air-jet sieve apparatus

The air inlet shall be fitted with a rotating jet consisting of a slot-shaped nozzle arranged radially beneath and very close to the sieve, so that when in rotation it blows air continuously through the sieve to keep the particles suspended.

The exhaust air pulls the finer particles through the sieve. The flow of air can be controlled by adjusting the working pressure, measured at the outlet; this may be achieved by means of an adjustable slot on the vacuum attachment.

NOTE Apparatus of construction different from that given in Figure 1 is allowed, provided that it has been verified that the results obtained are equivalent.

6.3 Timer (e.g. stopwatch), which indicates minutes and seconds and is equipped, if required, with a disconnecting switch for the motor of the sieve apparatus (6.2).

6.4 Balance, capable of being read to 0,01 g.

7 Procedure

Securely fix a sieve (see 6.1) into the sieve apparatus (6.2).

Weigh, to the nearest 0,1 g, the material to be sieved, transfer it onto the sieve, and place the cover on the sieve apparatus.

Regulate the flow of air to give a partial vacuum of 2,5 kPa (for example by means of the adjustable slot on the vacuum attachment — see 6.2).

Operate the motors of the sieve apparatus and the vacuum device for 4 min \pm 15 s for each sieving test.

If during the sieving process a deposit becomes visible under the lid, sieving shall be interrupted and the deposit brushed down onto the sieve.

The accuracy and precision of the method are not as good when the screen residue is small (less than 5 %, for example). In such cases it is of interest to extend the sieving time (to 10 min or even 15 min). However, for referee (in particular for designation) purposes, the value obtained after 4 min \pm 15 s shall be used.

After switching off the motors, weigh the residue on the sieve to the nearest 0,1 g (for example by weighing the sieve and its contents and subtracting the tare).

Repeat the procedure, as necessary, with sieves of different mesh aperture.

8 Expression of results

Calculate the sieve retention R , as a percentage, from the equation

$$R = \frac{m_1}{m_0} \times 100$$

where

m_0 is the mass, in grams, of sample used for the analysis;

m_1 is the mass, in grams, of the residue on the sieve.

Report the result to one decimal place.

9 Precision

Interlaboratory trials were conducted on four resins (including suspension homopolymer, emulsion homopolymer and graft copolymer) in five laboratories. For standard suspension resins, the repeatability standard deviation s_r (within the same laboratory) and the reproducibility standard deviation s_R (among different laboratories) are as given in Table 1.

Table 1

	Sieve retention, %	
	Mesh aperture 63 μm	Mesh aperture 250 μm
s_r	0,27	0,70
s_R	0,28	1,17

The full report on the round robin can be consulted at the following website address:

<http://standards.iso.org/iso/4610>

10 Test report

The test report shall include the following information:

- a) reference to this International Standard;
- b) all details necessary for complete identification of the resin analysed;
- c) the mass, in grams, of sample used for the analysis;
- d) the sieving time, in minutes;
- e) the partial vacuum, in kilopascals;
- f) the percentage retained on each sieve;
- g) the kind and amount of antistatic agent used for sample preparation;
- h) the date of the test.

ITEH STANDARD PREVIEW
(standards.iteh.ai)

[ISO 4610:2001](#)

<https://standards.iteh.ai/catalog/standards/sist/ce0758c6-a353-46cb-99e8-7468b15f4a2b/iso-4610-2001>

iTeh STANDARD PREVIEW
(standards.iteh.ai)

ISO 4610:2001

<https://standards.iteh.ai/catalog/standards/sist/ec0758c6-a353-46cb-99e8-7468b15f4a2b/iso-4610-2001>