**Paints and varnishes — Buchholz
indentation test**

Peintures et vernis — Essais d'indentation Buchholz

iTeh STANDARD PREVIEW
(standards.iteh.ai)

[ISO 2815:2003](https://standards.iteh.ai/catalog/standards/sist/e0b6853b-d11b-4530-bd61-d1faafe53f7/iso-2815-2003)

[https://standards.iteh.ai/catalog/standards/sist/e0b6853b-d11b-4530-
bd61-d1faafe53f7/iso-2815-2003](https://standards.iteh.ai/catalog/standards/sist/e0b6853b-d11b-4530-bd61-d1faafe53f7/iso-2815-2003)



PDF disclaimer

This PDF file may contain embedded typefaces. In accordance with Adobe's licensing policy, this file may be printed or viewed but shall not be edited unless the typefaces which are embedded are licensed to and installed on the computer performing the editing. In downloading this file, parties accept therein the responsibility of not infringing Adobe's licensing policy. The ISO Central Secretariat accepts no liability in this area.

Adobe is a trademark of Adobe Systems Incorporated.

Details of the software products used to create this PDF file can be found in the General Info relative to the file; the PDF-creation parameters were optimized for printing. Every care has been taken to ensure that the file is suitable for use by ISO member bodies. In the unlikely event that a problem relating to it is found, please inform the Central Secretariat at the address given below.

iTeh STANDARD PREVIEW
(standards.iteh.ai)

ISO 2815:2003

<https://standards.iteh.ai/catalog/standards/sist/e0b6853b-d11b-4530-bd61-d1faafe5Bf7/iso-2815-2003>

© ISO 2003

All rights reserved. Unless otherwise specified, no part of this publication may be reproduced or utilized in any form or by any means, electronic or mechanical, including photocopying and microfilm, without permission in writing from either ISO at the address below or ISO's member body in the country of the requester.

ISO copyright office
Case postale 56 • CH-1211 Geneva 20
Tel. + 41 22 749 01 11
Fax + 41 22 749 09 47
E-mail copyright@iso.org
Web www.iso.org

Published in Switzerland

Contents

Page

Foreword.....	iv
1 Scope.....	1
2 Normative references	1
3 Principle	1
4 Apparatus.....	1
5 Sampling	4
6 Test panels	4
7 Procedure.....	5
8 Calculation and expression of results	6
9 Precision	6
10 Test report.....	7
Annex A (informative) Buchholz indentation resistance	8

iTeh STANDARD PREVIEW
(standards.iteh.ai)

[ISO 2815:2003](https://standards.iteh.ai/catalog/standards/sist/e0b6853b-d11b-4530-bd61-d1faafe53f7/iso-2815-2003)

<https://standards.iteh.ai/catalog/standards/sist/e0b6853b-d11b-4530-bd61-d1faafe53f7/iso-2815-2003>

Foreword

ISO (the International Organization for Standardization) is a worldwide federation of national standards bodies (ISO member bodies). The work of preparing International Standards is normally carried out through ISO technical committees. Each member body interested in a subject for which a technical committee has been established has the right to be represented on that committee. International organizations, governmental and non-governmental, in liaison with ISO, also take part in the work. ISO collaborates closely with the International Electrotechnical Commission (IEC) on all matters of electrotechnical standardization.

International Standards are drafted in accordance with the rules given in the ISO/IEC Directives, Part 2.

The main task of technical committees is to prepare International Standards. Draft International Standards adopted by the technical committees are circulated to the member bodies for voting. Publication as an International Standard requires approval by at least 75 % of the member bodies casting a vote.

Attention is drawn to the possibility that some of the elements of this document may be the subject of patent rights. ISO shall not be held responsible for identifying any or all such patent rights.

ISO 2815 was prepared by Technical Committee ISO/TC 35, *Paints and varnishes*, Subcommittee SC 9, *General test methods for paints and varnishes*.

This second edition cancels and replaces the first edition (ISO 2815:1973), which has been technically revised. The main changes are as follows:

- only indentation length is now determined;
- the conversion of indentation length to indentation resistance is described in an informative annex.

iTeh STANDARD PREVIEW
(standards.iteh.ai)

[ISO 2815:2003](#)

<https://standards.iteh.ai/catalog/standards/sist/e0b6853b-d11b-4530-bd61-d11aaf55b17/iso-2815-2003>

Paints and varnishes — Buchholz indentation test

1 Scope

This International Standard describes a method for carrying out an indentation test on a single coating or multicoat system of paint, varnish or related product, using a Buchholz indentor. The length of the indentation produced is indicative of the residual deformation of the coating.

This indentation test is not suitable for products which contain a strong plasticizer.

NOTE 1 Since the indentation test, like other physical tests on paints, gives results which can be dependent upon time, temperature and humidity, comparable results will only be obtained if the test is carried out under well-defined conditions.

NOTE 2 Since the indentation depth depends upon the film thickness, the result obtained for the indentation length is only valid if the coating thickness exceeds a certain minimum value (see Annex A).

2 Normative references

The following referenced documents are indispensable for the application of this document. For dated references, only the edition cited applies. For undated references, the latest edition of the referenced document (including any amendments) applies.

ISO 1513, *Paints and varnishes — Examination and preparation of samples for testing*

ISO 1514, *Paints and varnishes — Standard panels for testing*

ISO 2808, *Paints and varnishes — Determination of film thickness*

ISO 15528, *Paints, varnishes and raw materials for paints and varnishes — Sampling*

3 Principle

An indentor of specified size and shape is applied to the coating under defined conditions. The indentation length is measured in millimetres (see Annex A).

4 Apparatus

4.1 Indentation apparatus

This is shown in Figure 1. It consists essentially of a rectangular block of metal, which forms the body of the instrument, an indentor and two pointed feet.

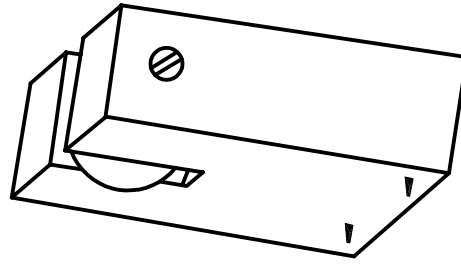
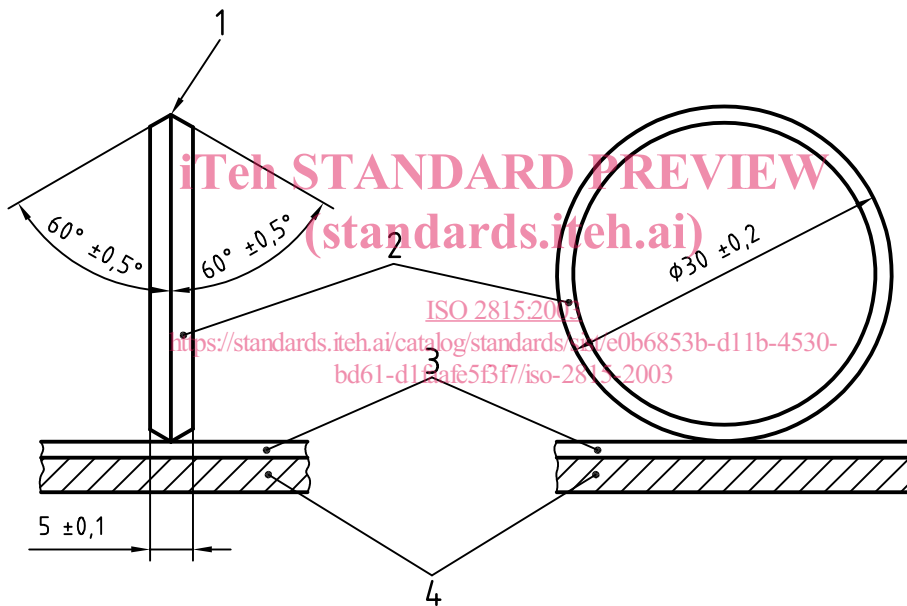

Figure 1 — Indentation apparatus (oblique underside view)

The indenter is a sharpened sharp-edged metal wheel of hardened tool steel. The cross-section through its axis of rotation and its dimensions shall be as shown in Figure 2. Figures 3a) and 3b) show the shape of the indentation produced.

Dimensions in millimetres



Key

- 1 sharp edge
- 2 indenter
- 3 coating
- 4 substrate

Figure 2 — Buchholz indenter

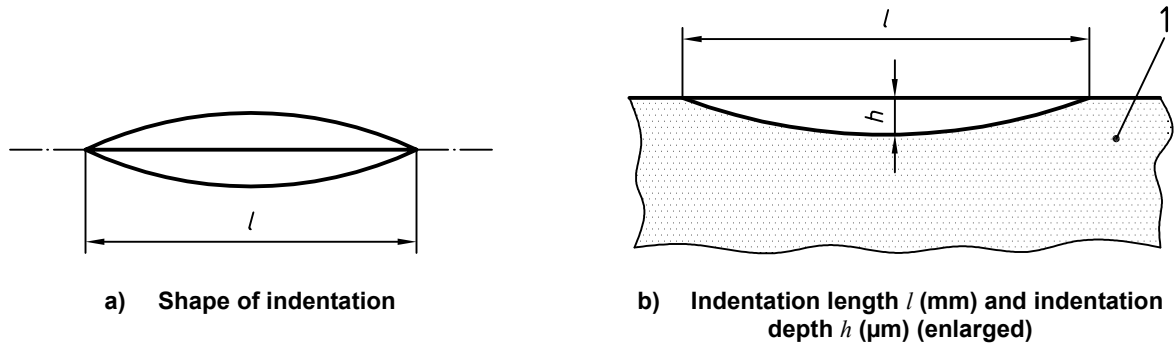
**Key**

1 coating

Figure 3 — Shape of indentation

The indenter and the two feet are so positioned in the body that, when the instrument is placed on a level surface, it is stable, its upper surface is horizontal and the effective load upon the indenter is (500 ± 5) g.

4.2 Measuring device

A suitable device for measuring the length of the indentation consists of a microscope with $\times 20$ magnification and an eyepiece fitted with a graduated scale capable of reading to 0.1 mm. The area of indentation shall be illuminated by means of a light source located so that the angle of incidence of the light exceeds 60° , as shown in Figure 4. The microscope shall be positioned vertically over the illuminated area and focused to bring the shadow produced by the indentation (see Figures 4 and 5) and the graduated scale together.

NOTE The position of the indentation mark can be located by means of a suitable template prepared from a triangular sheet of transparent plastics film (see Figure 6).

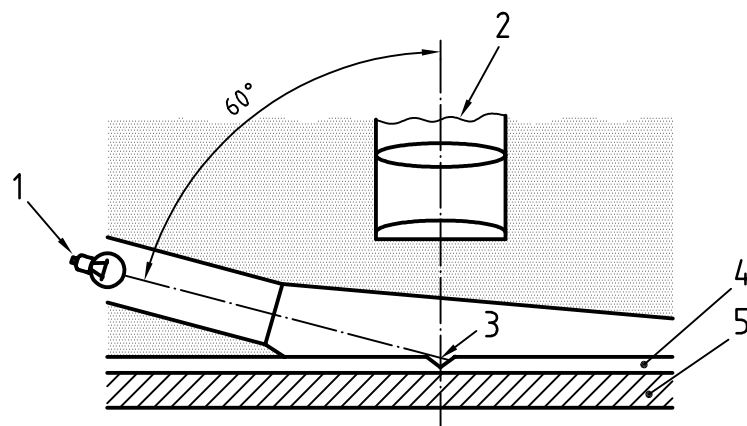
**Key**

- 1 light source
- 2 microscope
- 3 indentation
- 4 coating
- 5 substrate

Figure 4 — Position of the light source and the microscope

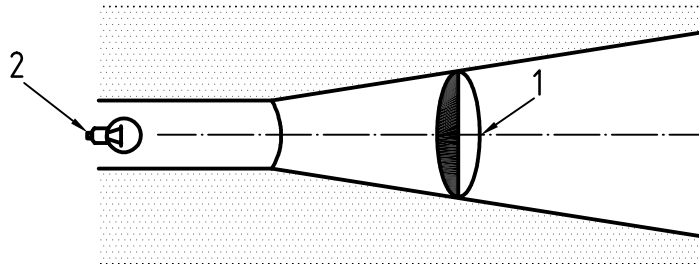

Key

- 1 indentation visible by its shadow
- 2 light source

Figure 5 — Shadow produced by the indentation

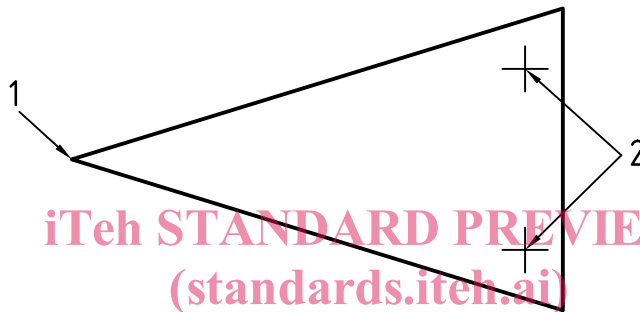

iTeh STANDARD PREVIEW
(standards.iteh.ai)

Key

- 1 position of the indentation
- 2 position of the feet of the instrument

ISO 2815:2003
<https://standards.iteh.ai/catalog/standards/sist/e0b6853b-d11b-4530-bd61-d1faafe53f7/iso-2815-2003>

Figure 6 — Template to locate the position of the indentation

4.3 Timing device

Use a stopwatch or other suitable timing device capable of measuring 30 s to the nearest 1 s.

5 Sampling

Take a representative sample of the product to be tested (or of each product in the case of a multicoat system), as described in ISO 15528. The sample shall then be examined and prepared for testing as described in ISO 1513.

6 Test panels

6.1 Materials and dimensions

Unless otherwise agreed, the test panels shall be of metal or glass conforming to the requirements of ISO 1514.

The test panels shall be flat and free from distortion, and the surface shall be free from any visible ridges or cracks.

Unless otherwise agreed, the test panels shall have minimum dimensions of 150 mm × 100 mm and a thickness of not less than 0,75 mm.

NOTE The test panels may be cut to size after coating and drying, provided no distortion occurs.

6.2 Preparation and coating of panels

The test panels shall be prepared in accordance with ISO 1514, unless otherwise agreed, and shall then be coated by the specified method with the product or system under test to the specified film thickness limits. Any variation from the requirements of ISO 1514 shall be noted in the test report (see Clause 10).

6.3 Drying and conditioning of the test panels

The coated test panels shall be dried (or stoved) and aged (if applicable) for the specified time and under the specified conditions and, unless otherwise specified, shall be conditioned at a temperature of (23 ± 2) °C and a relative humidity of (50 ± 5) % for a minimum of 16 h. The test procedure shall then be carried out as soon as possible.

6.4 Thickness of coating

The average thickness, in micrometres, of the dry coating in the region to be tested shall be determined by the method specified, using one of the procedures specified in ISO 2808.

7 Procedure

iTeh STANDARD PREVIEW
(standards.iteh.ai)

7.1 Ambient conditions

The test shall be carried out at a temperature of (23 ± 2) °C and a relative humidity of (50 ± 5) %, unless otherwise agreed.

7.2 Determination of indentation length

Place the test panel, paint film uppermost, on a firm horizontal surface.

Take the indentation apparatus (4.1) and place it gently and without any tilting or lateral movement on the test panel, leave the indenter in position for (30 ± 1) s and remove it carefully.

When the apparatus is put in place, the feet of the apparatus shall first be allowed to make contact with the test panel and then the indenter lowered carefully until it touches the panel. When the apparatus is removed, it shall be lifted off indenter first and feet last.

Place the light source and microscope in position as specified in 4.2 and measure the length, in millimetres, of the shadow produced by the indentation (35 ± 5) s after removal of the indenter, unless otherwise specified. Record the result in millimetres, to the nearest 0,1 mm, as the indentation length.

Carry out five tests on different parts of the same test panel and calculate the mean value.

Table 1 shows the relationship between the indentation length, in millimetres, the indentation depth, in micrometres, and the minimum coating thickness, also in micrometres, for which the measurement is valid. Discard any results which fall outside these limits.