



Designation: D 698 – 00a^{e1}

Standard Test Methods for Laboratory Compaction Characteristics of Soil Using Standard Effort (12,400 ft-lbf/ft³(600 kN-m/m³))¹

This standard is issued under the fixed designation D 698; the number immediately following the designation indicates the year of original adoption or, in the case of revision, the year of last revision. A number in parentheses indicates the year of last reapproval. A superscript epsilon (ϵ) indicates an editorial change since the last revision or reapproval.

^{e1} NOTE—Paragraph 10.4.3 was corrected editorially in November 2003.

1. Scope*

1.1 These test methods covers laboratory compaction methods used to determine the relationship between water content and dry unit weight of soils (compaction curve) compacted in a 4 or 6-in. (101.6 or 152.4-mm) diameter mold with a 5.5-lbf (24.4-N) rammer dropped from a height of 12 in. (305 mm) producing a compactive effort of 12,400 ft-lbf/ft³(600 kN-m/m³).

NOTE 1—The equipment and procedures are similar as those proposed by R. R. Proctor (*Engineering News Record*—September 7, 1933) with this one major exception: his rammer blows were applied as “12 inch firm strokes” instead of free fall, producing variable compactive effort depending on the operator, but probably in the range 15,000 to 25,000 ft-lbf/ft³ (700 to 1,200 kN-m/m³). The standard effort test (see 3.2.2) is sometimes referred to as the Proctor Test.

NOTE 2—Soils and soil-aggregate mixtures should be regarded as natural occurring fine- or coarse-grained soils or composites or mixtures of natural soils, or mixtures of natural and processed soils or aggregates such as silt, gravel, or crushed rock.

1.2 These test methods apply only to soils (materials) that have 30 % or less by mass of particles retained on the ¾-inch (19.0-mm) sieve.

NOTE 3—For relationships between unit weights and water contents of soils with 30 % or less by mass of material retained on the ¾-in. (19.0-mm) sieve to unit weights and water contents of the fraction passing ¾-in. (19.0-mm) sieve, see Practice D 4718.

1.3 Three alternative methods are provided. The method used shall be as indicated in the specification for the material being tested. If no method is specified, the choice should be based on the material gradation.

1.3.1 Method A:

1.3.1.1 *Mold*—4-in. (101.6-mm) diameter.

1.3.1.2 *Material*—Passing No. 4 (4.75-mm) sieve.

1.3.1.3 *Layers*—Three.

1.3.1.4 *Blows per layer*—25.

1.3.1.5 *Use*—May be used if 20 % or less by mass of the material is retained on the No. 4 (4.75-mm) sieve.

1.3.1.6 *Other Use*—If this method is not specified, materials that meet these gradation requirements may be tested using Methods B or C.

1.3.2 Method B:

1.3.2.1 *Mold*—4-in. (101.6-mm) diameter.

1.3.2.2 *Material*—Passing ⅜-in. (9.5-mm) sieve.

1.3.2.3 *Layers*—Three.

1.3.2.4 *Blows per layer*—25.

1.3.2.5 *Use*—Shall be used if more than 20 % by mass of the material is retained on the No. 4 (4.75-mm) sieve and 20 % or less by mass of the material is retained on the ⅜-in. (9.5-mm) sieve.

1.3.2.6 *Other Use*—If this method is not specified, materials that meet these gradation requirements may be tested using Method C.

1.3.3 Method C:

1.3.3.1 *Mold*—6-in. (152.4-mm) diameter.

1.3.3.2 *Material*—Passing ¾-inch (19.0-mm) sieve.

1.3.3.3 *Layers*—Three.

1.3.3.4 *Blows per layer*—56.

1.3.3.5 *Use*—Shall be used if more than 20 % by mass of the material is retained on the ⅜-in. (9.5-mm) sieve and less than 30 % by mass of the material is retained on the ¾-in. (19.0-mm) sieve.

1.3.4 The 6-in. (152.4-mm) diameter mold shall not be used with Method A or B.

NOTE 4—Results have been found to vary slightly when a material is tested at the same compactive effort in different size molds.

1.4 If the test specimen contains more than 5 % by mass of oversize fraction (coarse fraction) and the material will not be included in the test, corrections must be made to the unit mass and water content of the specimen or to the appropriate field in place density test specimen using Practice D 4718.

1.5 This test method will generally produce a well defined maximum dry unit weight for non-free draining soils. If this test method is used for free draining soils the maximum unit

¹ This standard is under the jurisdiction of ASTM Committee D18 on Soil and Rock and is the direct responsibility of Subcommittee D18.03 on Texture, Plasticity and Density Characteristics of Soils.

Current edition approved June 10, 2000. Published September 2000. Originally published as D 698 – 42T. Last previous edition D 698 – 00.

*A Summary of Changes section appears at the end of this standard.

weight may not be well defined, and can be less than obtained using Test Methods **D 4253**.

1.6 The values in inch-pound units are to be regarded as the standard. The values stated in SI units are provided for information only.

1.6.1 In the engineering profession it is customary practice to use, interchangeably, units representing both mass and force, unless dynamic calculations ($F = Ma$) are involved. This implicitly combines two separate systems of units, that is, the absolute system and the gravimetric system. It is scientifically undesirable to combine the use of two separate systems within a single standard. This test method has been written using inch-pound units (gravimetric system) where the pound (lbf) represents a unit of force. The use of mass (lbm) is for convenience of units and is not intended to convey the use is scientifically correct. Conversions are given in the SI system in accordance with IEEE/ASTM SI 10. The use of balances or scales recording pounds of mass (lbm), or the recording of density in lbm/ft³ should not be regarded as nonconformance with this standard.

1.7 *This standard does not purport to address all of the safety concerns, if any, associated with its use. It is the responsibility of the user of this standard to establish appropriate safety and health practices and determine the applicability of regulatory limitations prior to use.*

2. Referenced Documents

2.1 ASTM Standards:

- C 127** Test Method for Specific Gravity and Absorption of Coarse Aggregate²
- C 136** Method for Sieve Analysis of Fine and Coarse Aggregate²
- D 422** Test Method for Particle Size Analysis of Soils³
- D 653** Terminology Relating to Soil, Rock, and Contained Fluids³
- D 854** Test Methods for Specific Gravity of Soil Solids by Water Pycnometer³
- D 1557** Test Methods for Laboratory Compaction Characteristics of Soil Using Modified Efforts (56,000 ft-lbf/ft³(2,700 kN-m/m³)) Drop³
- D 2168** Test Methods for Calibration of Laboratory Mechanical-Rammer Soil Compactors³
- D 2216** Test Method for Laboratory Determination of Water (Moisture) Content of Soil and Rock by Mass³
- D 2487** Practice for Classification of Soils for Engineering Purposes (Unified Soil Classification System)³
- D 2488** Practice for Description and Identification of Soils (Visual-Manual Procedure)³
- D 3740** Practice for Minimum Requirements for Agencies Engaged in the Testing and/or Inspection of Soil and Rock as Used in Engineering Design and Construction³
- D 4220** Practices for Preserving and Transporting Soil Samples³
- D 4253** Test Methods for Maximum Index Density and Unit Weight of Soils Using a Vibratory Table³

- D 4718** Practice for Correction of Unit Weight and Water Content for Soils Containing Oversize Particles³
- D 4753** Specification for Evaluating, Selecting and Specifying Balances and Scales For Use in Soil, Rock, and Construction Materials Testing³
- D 4914** Test Methods for Density of Soil and Rock in Place by the Sand Replacement Method in a Test Pit³
- D 5030** Test Method for Density of Soil and Rock in Place by the Water Replacement Method in a Test Pit³
- D 6026** Practice for Using Significant Digits in Geotechnical Data⁴
- E 1** Specification for ASTM Thermometers⁵
- E 11** Specification for Wire-Cloth Sieves for Testing Purposes⁶
- E 177** Practice for Use of the Terms Precision and Bias in ASTM Test Methods⁷
- E 319** Practice for the Evaluation of Single-Pan Mechanical Balances⁶
- E 691** Practice for Conducting an Interlaboratory Study to Determine the Precision of a Test Method⁶
- IEEE/ASTM SI 10 Standard for Use of the International System of Units (SI): the Modern Metric System⁸

3. Terminology

3.1 *Definitions:* See Terminology **D 653** for general definitions.

3.2 *Description of Terms Specific to This Standard:*

3.2.1 *oversize fraction (coarse fraction), P_c in %*—the portion of total sample not used in performing the compaction test; it may be the portion of total sample retained on the No. 4 (4.75-mm), $\frac{3}{8}$ -in. (9.5-mm), or $\frac{3}{4}$ -in. (19.0-mm) sieve.

3.2.2 *standard effort*—the term for the 12,400 ft-lbf/ft³ (600 kN-m/m³) compactive effort applied by the equipment and methods of this test.

3.2.3 *standard maximum dry unit weight, γ_{dmax} in lbf/ft³ (kN/m³)*—the maximum value defined by the compaction curve for a compaction test using standard effort.

3.2.4 *standard optimum water content, w , in %*—the water content at which a soil can be compacted to the maximum dry unit weight using standard compactive effort.

3.2.5 *test fraction (finer fraction), P_F in %*—the portion of the total sample used in performing the compaction test; it is the fraction passing the No. 4 (4.75-mm) sieve in Method A, minus $\frac{3}{8}$ -in. (9.5-mm) sieve in Method B, or minus $\frac{3}{4}$ -in. (19.0-mm) sieve in Method C.

4. Summary of Test Method

4.1 A soil at a selected water content is placed in three layers into a mold of given dimensions, with each layer compacted by 25 or 56 blows of a 5.5-lbf (24.4-N) rammer dropped from a distance of 12-in. (305-mm), subjecting the soil to a total compactive effort of about 12,400 ft-lbf/ft³ (600 kN-m/m³). The resulting dry unit weight is determined. The

⁴ Annual Book of ASTM Standards, Vol 04.09.

⁵ Annual Book of ASTM Standards, Vol 14.03.

⁶ Annual Book of ASTM Standards, Vol 14.02.

⁷ Annual Book of ASTM Standards, Vol 15.09.

⁸ Annual Book of ASTM Standards, Vol 14.04.

² Annual Book of ASTM Standards, Vol 04.02.

³ Annual Book of ASTM Standards, Vol 04.08.

procedure is repeated for a sufficient number of water contents to establish a relationship between the dry unit weight and the water content for the soil. This data, when plotted, represents a curvilinear relationship known as the compaction curve. The values of optimum water content and standard maximum dry unit weight are determined from the compaction curve.

5. Significance and Use

5.1 Soil placed as engineering fill (embankments, foundation pads, road bases) is compacted to a dense state to obtain satisfactory engineering properties such as, shear strength, compressibility, or permeability. Also, foundation soils are often compacted to improve their engineering properties. Laboratory compaction tests provide the basis for determining the percent compaction and water content needed to achieve the required engineering properties, and for controlling construction to assure that the required compaction and water contents are achieved.

5.2 During design of an engineered fill, shear, consolidation, permeability, or other tests require preparation of test specimens by compacting at some water content to some unit weight. It is common practice to first determine the optimum water content (w_o) and maximum dry unit weight (γ_{dmax}) by means of a compaction test. Test specimens are compacted at a selected water content (w), either wet or dry of optimum (w_o) or at optimum (w_o), and at a selected dry unit weight related to a percentage of maximum dry unit weight (γ_{dmax}). The selection of water content (w), either wet or dry of optimum (w_o) or at optimum (w_o) and the dry unit weight (γ_{dmax}) may be based on past experience, or a range of values may be investigated to determine the necessary percent of compaction.

5.3 Experience indicates that the methods outlined in 5.2 or the construction control aspects discussed in 5.1 are extremely difficult to implement or yield erroneous results when dealing with certain soils. 5.3.1-5.3.3 describe typical problem soils, the problems encountered when dealing with such soils and possible solutions for these problems.

5.3.1 *Oversize Fraction*—Soils containing more than 30 % oversize fraction (material retained on the 3/4-in. (19-mm) sieve) are a problem. For such soils, there is no ASTM test method to control their compaction and very few laboratories are equipped to determine the laboratory maximum unit weight (density) of such soils (USDI Bureau of Reclamation, Denver, CO and U.S. Army Corps of Engineers, Vicksburg, MS). Although Test Methods D 4914 and D 5030 determine the “field” dry unit weight of such soils, they are difficult and expensive to perform.

5.3.1.1 One method to design and control the compaction of such soils is to use a test fill to determine the required degree of compaction and the method to obtain that compaction, followed by use of a method specification to control the compaction. Components of a method specification typically contain the type and size of compaction equipment to be used, the lift thickness, and the number of passes.

NOTE 5—Success in executing the compaction control of an earthwork project, especially when a method specification is used, is highly dependent upon the quality and experience of the “contractor” and “inspector.”

5.3.1.2 Another method is to apply the use of density correction factors developed by the USDI Bureau of Reclamation (1,2)⁹ and U.S. Corps of Engineers (3). These correction factors may be applied for soils containing up to about 50 to 70 % oversize fraction. Each agency uses a different term for these density correction factors. The USDI Bureau of Reclamation uses *D* ratio (or *D* – VALUE), while the U.S. Corps of Engineers uses Density Interference Coefficient (I_c).

5.3.1.3 The use of the replacement technique (Test Method D 698–78, Method D), in which the oversize fraction is replaced with a finer fraction, is inappropriate to determine the maximum dry unit weight, γ_{dmax} , of soils containing oversize fractions (3).

5.3.2 *Degradation*—Soils containing particles that degrade during compaction are a problem, especially when more degradation occurs during laboratory compaction than field compaction, as is typical. Degradation typically occurs during the compaction of a granular-residual soil or aggregate. When degradation occurs, the maximum dry-unit weight increases (4) so that the laboratory maximum value is not representative of field conditions. Often, in these cases, the maximum dry unit weight is impossible to achieve in the field.

5.3.2.1 Again, for soils subject to degradation, the use of test fills and method specifications may help. Use of replacement techniques is not correct.

5.3.3 *Gap Graded*—Gap-graded soils (soils containing many large particles with limited small particles) are a problem because the compacted soil will have larger voids than usual. To handle these large voids, standard test methods (laboratory or field) typically have to be modified using engineering judgement.

NOTE 6—The quality of the result produced by this standard is dependent on the competence of the personnel performing it, and the suitability of the equipment and facilities used. Agencies that meet the criteria of Practice D 3740 are generally considered capable of competent and objective testing/sampling/inspection, and the like. Users of this standard are cautioned that compliance with Practice D 3740 does not in itself assure reliable results. Reliable results depend on many factors; Practice D 3740 provides a means of evaluating some of those factors.

6. Apparatus

6.1 *Mold Assembly* —The molds shall be cylindrical in shape, made of rigid metal and be within the capacity and dimensions indicated in 6.1.1 or 6.1.2 and Fig. 1 and Fig. 2. See also Table 1. The walls of the mold may be solid, split, or tapered. The “split” type may consist of two half-round sections, or a section of pipe split along one element, which can be securely locked together to form a cylinder meeting the requirements of this section. The “tapered” type shall an internal diameter taper that is uniform and not more than 0.200 in./ft (16.7- mm/m) of mold height. Each mold shall have a base plate and an extension collar assembly, both made of rigid metal and constructed so they can be securely attached and easily detached from the mold. The extension collar assembly shall have a height extending above the top of the mold of at

⁹ The boldface numbers in parentheses refer to the list of references at the end of this standard.

As an option to the full length stud, a 2 1/2" x 3/8" stud may be used. Then as an alternative construction, the collar may be held down with a slotted bracket attached to the collar and a pin in the mold.

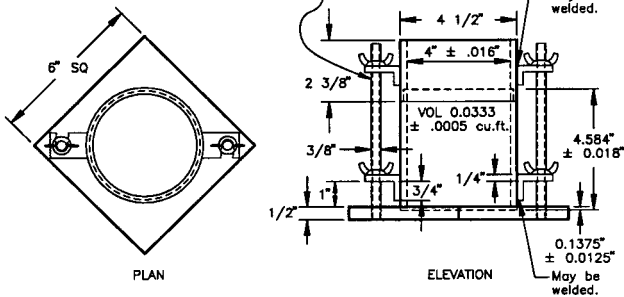

FIG. 1 4.0-in. Cylindrical Mold

As an option to the full length stud, a 2 1/2" x 3/8" stud may be used. Then as an alternative construction, the collar may be held down with a slotted bracket attached to the collar and a pin in the mold.

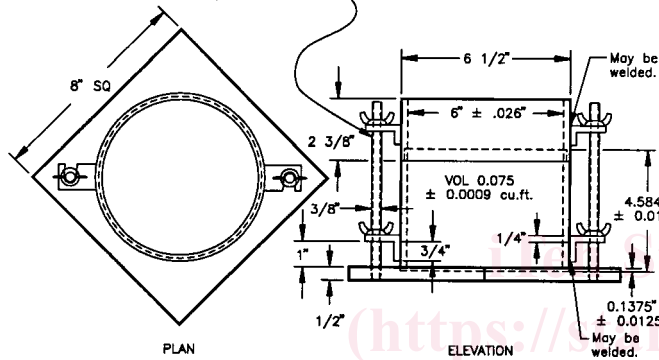

FIG. 2 6.0-in. Cylindrical Mold

TABLE 1 Metric Equivalents for Figs. 1 and 2

in.	mm
0.016	0.41
0.026	0.66
0.032	0.81
0.028	0.71
1/2	12.70
2 1/2	63.50
2 5/8	66.70
4	101.60
4 1/2	114.30
4.584	116.43
4 3/4	120.60
6	152.40
6 1/2	165.10
6 5/8	168.30
6 3/4	171.40
8 1/4	209.60
ft ³	cm ³
1/30 (0.0333)	943
0.0005	14
(0.0750)	2,124
0.0011	31

least 2.0 in. (50.8-mm) which may include an upper section that flares out to form a funnel provided there is at least a 0.75 in. (19.0-mm) straight cylindrical section beneath it. The extension collar shall align with the inside of the mold. The

bottom of the base plate and bottom of the centrally recessed area that accepts the cylindrical mold shall be planar.

6.1.1 *Mold, 4 in.*—A mold having a 4.000 ± 0.016-in. (101.6 ± 0.4-mm) average inside diameter, a height of 4.584 ± 0.018 in. (116.4 ± 0.5 mm) and a volume of 0.0333 ± 0.0005 ft³ (944 ± 14 cm³). A mold assembly having the minimum required features is shown in Fig. 1.

6.1.2 *Mold, 6 in.*—A mold having a 6.000 ± 0.026-in. (152.4 ± 0.7-mm) average inside diameter, a height of 4.584 ± 0.018 in. (116.4 ± 0.5 mm), and a volume of 0.075 ± 0.0009 ft³ (2124 ± 25 cm³). A mold assembly having the minimum required features is shown in Fig. 2.

6.2 *Rammer*—A rammer, either manually operated as described further in 6.2.1 or mechanically operated as described in 6.2.2. The rammer shall fall freely through a distance of 12 ± 0.05 in. (304.8 ± 1.3 mm) from the surface of the specimen. The mass of the rammer shall be 5.5 ± 0.02 lbm (2.5 ± 0.01 kg), except that the mass of the mechanical rammers may be adjusted as described in Test Methods D 2168; see Note 7. The striking face of the rammer shall be planar and circular, except as noted in 6.2.2.1, with a diameter when new of 2.000 ± 0.005 in. (50.80 ± 0.13 mm). The rammer shall be replaced if the striking face becomes worn or bellied to the extent that the diameter exceeds 2.000 ± 0.01 in. (50.80 ± 0.25 mm).

NOTE 7—It is a common and acceptable practice in the inch-pound system to assume that the mass of the rammer is equal to its mass determined using either a kilogram or pound balance and 1 lbf is equal to 1 lbm or 0.4536 kg, or 1 N is equal to 0.2248 lbm or 0.1020 kg.

6.2.1 *Manual Rammer*—The rammer shall be equipped with a guide sleeve that has sufficient clearance that the free fall of the rammer shaft and head is not restricted. The guide sleeve shall have at least four vent holes at each end (eight holes total) located with centers 3/4 ± 1/16-in. (19.0 ± 1.6-mm) from each end and spaced 90 degrees apart. The minimum diameter of the vent holes shall be 3/8-in. (9.5-mm). Additional holes or slots may be incorporated in the guide sleeve.

6.2.2 *Mechanical Rammer-Circular Face* —The rammer shall operate mechanically in such a manner as to provide uniform and complete coverage of the specimen surface. There shall be 0.10 ± 0.03-in. (2.5 ± 0.8-mm) clearance between the rammer and the inside surface of the mold at its smallest diameter. The mechanical rammer shall meet the calibration requirements of Test Methods D 2168. The mechanical rammer shall be equipped with a positive mechanical means to support the rammer when not in operation.

6.2.2.1 *Mechanical Rammer-Sector Face*—When used with the 6-in. (152.4-mm) mold, a sector face rammer may be used in place of the circular face rammer. The specimen contact face shall have the shape of a sector of a circle of radius equal to 2.90 ± 0.02-in. (73.7 ± 0.5-mm). The rammer shall operate in such a manner that the vertex of the sector is positioned at the center of the specimen.

6.3 *Sample Extruder (optional)* —A jack, frame or other device adapted for the purpose of extruding compacted specimens from the mold.

6.4 *Balance* —A class GP5 balance meeting the requirements of Specification **D 4753** for a balance of 1-g readability.

6.5 *Drying Oven* —Thermostatically controlled, preferably of a forced-draft type and capable of maintaining a uniform temperature of $230 \pm 9^\circ\text{F}$ ($110 \pm 5^\circ\text{C}$) throughout the drying chamber.

6.6 *Straightedge* —A stiff metal straightedge of any convenient length but not less than 10 in. (254 mm). The total length of the straightedge shall be machined straight to a tolerance of ± 0.005 in. ($\pm 0.1\text{mm}$). The scraping edge shall be beveled if it is thicker than $\frac{1}{8}$ in. (3 mm).

6.7 *Sieves* — $\frac{3}{4}$ in. (19.0 mm), $\frac{3}{8}$ in. (9.5 mm), and No. 4 (4.75 mm), conforming to the requirements of Specification **E 11**.

6.8 *Mixing Tools* —Miscellaneous tools such as mixing pan, spoon, trowel, spatula, etc., or a suitable mechanical device for thoroughly mixing the sample of soil with increments of water.

7. Calibration

7.1 Perform calibrations before initial use, after repairs or other occurrences that might affect the test results, at intervals not exceeding 1,000 test specimens, or annually, whichever occurs first, for the following apparatus:

7.1.1 *Balance*—Evaluate in accordance with Specification **D 4753**.

7.1.2 *Molds*—Determine the volume as described in **Annex A1**.

7.1.3 *Manual Rammer*—Verify the free fall distance, rammer mass, and rammer face in accordance with **6.2**. Verify the guide sleeve requirements in accordance with **6.2.1**.

7.1.4 *Mechanical Rammer*—Calibrate and adjust the mechanical rammer in accordance with Test Methods **D 2168**. In addition, the clearance between the rammer and the inside surface of the mold shall be verified in accordance with **6.2.2**.

8. Test Sample

8.1 The required sample mass for Methods A and B is approximately 35 lbm (16 kg), and for Method C is approximately 65-lbm (29-kg) of dry soil. Therefore, the field sample should have a moist mass of at least 50 lbm (23 kg) and 100 lbm (45 kg), respectively.

8.2 Determine the percentage of material (by mass) retained on the No. 4 (4.75-mm), $\frac{3}{8}$ -in. (9.5-mm), or $\frac{3}{4}$ -in. (19.0-mm) sieve as appropriate for choosing Method A, B, or C. Make this determination by separating out a representative portion from the total sample and determining the percentages passing the sieves of interest by Test Methods **D 422** or Method **C 136**. It is only necessary to calculate percentages for the sieve or sieves for which information is desired.

9. Preparation of Apparatus

9.1 Select the proper compaction mold in accordance with the Method (A, B, or C) being used. Determine and record its mass to the nearest gram. Assemble the mold, base and extension collar. Check the alignment of the inner wall of the mold and mold extension collar. Adjust if necessary.

9.2 Check that the rammer assembly is in good working condition and that parts are not loose or worn. Make any

necessary adjustments or repairs. If adjustments or repairs are made, the rammer must be recalibrated.

10. Procedure

10.1 *Soils*:

10.1.1 Do not reuse soil that has been previously compacted in the laboratory.

10.1.2 When using this test method for soils containing hydrated halloysite, or where past experience with a particular soil indicates that results will be altered by air drying, use the moist preparation method (see **10.2**).

10.1.3 Prepare the soil specimens for testing in accordance with **10.2** (preferred) or with **10.3**.

10.2 *Moist Preparation Method (preferred)*—Without previously drying the sample, pass it through a No. 4 (4.75-mm), $\frac{3}{8}$ -in. (9.5-mm), or $\frac{3}{4}$ -in. (19.0-mm) sieve, depending on the Method (A, B, or C) being used. Determine the water content of the processed soil.

10.2.1 Prepare at least four (preferably five) specimens having water contents such that they bracket the estimated optimum water content. A specimen having a water content close to optimum should be prepared first by trial additions of water and mixing (see **Note 8**). Select water contents for the rest of the specimens to provide at least two specimens wet and two specimens dry of optimum, and water contents varying by about 2 %. At least two water contents are necessary on the wet and dry side of optimum to accurately define the dry unit weight compaction curve (see **10.5**). Some soils with very high optimum water content or a relatively flat compaction curve may require larger water content increments to obtain a well defined maximum dry unit weight. Water content increments should not exceed 4 %.

NOTE 8—With practice it is usually possible to visually judge a point near optimum water content. Typically, soil at optimum water content can be squeezed into a lump that sticks together when hand pressure is released, but will break cleanly into two sections when “bent”. At water contents dry of optimum soils tend to crumble; wet of optimum soils tend to stick together in a sticky cohesive mass. Optimum water content is typically slightly less than the plastic limit.

10.2.2 Use approximately 5-lbm (2.3-kg) of the sieved soil for each specimen to be compacted using Method A or B, or 13-lbm (5.9-kg) using Method C. To obtain the specimen water contents selected in **10.2.1**, add or remove the required amounts of water as follows: to add water, spray it into the soil during mixing; to remove water, allow the soil to dry in air at ambient temperature or in a drying apparatus such that the temperature of the sample does not exceed 140°F (60°C). Mix the soil frequently during drying to maintain an even water content distribution. Thoroughly mix each specimen to ensure even distribution of water throughout and then place in a separate covered container and allow to stand in accordance with **Table 2** prior to compaction. For the purpose of selecting

TABLE 2 Required Standing Times of Moisturized Specimens

Classification	Minimum Standing Time, h
GW, GP, SW, SP	No Requirement
GM, SM	3
All other soils	16

a standing time, the soil may be classified using Test Method **D 2487**, Practice **D 2488** or data on other samples from the same material source. For referee testing, classification shall be by Test Method **D 2487**.

10.3 Dry Preparation Method—If the sample is too damp to be friable, reduce the water content by air drying until the material is friable. Drying may be in air or by the use of drying apparatus such that the temperature of the sample does not exceed 140°F (60°C). Thoroughly break up the aggregations in such a manner as to avoid breaking individual particles. Pass the material through the appropriate sieve: No. 4 (4.75-mm), 3/8-in. (9.5-mm), or 3/4-in. (19.0-mm). When preparing the material by passing over the 3/4-in. sieve for compaction in the 6-in. mold, break up aggregations sufficiently to at least pass the 3/8-in. sieve in order to facilitate the distribution of water throughout the soil in later mixing.

10.3.1 Prepare at least four (preferably five) specimens in accordance with **10.2.1**.

10.3.2 Use approximately 5-lbm (2.3-kg) of the sieved soil for each specimen to be compacted using Method A or B, or 13-lbm (5.9-kg) using Method C. Add the required amounts of water to bring the water contents of the specimens to the values selected in **10.3.1**. Follow the specimen preparation method specified in **10.2.2** for drying the soil or adding water into the soil and curing each test specimen.

10.4 Compaction—After curing, if required, each specimen shall be compacted as follows:

10.4.1 Determine and record the mass of the mold or mold and base plate.

10.4.2 Assemble and secure the mold and collar to the base plate. The mold shall rest on a uniform rigid foundation, such as provided by a cylinder or cube of concrete with a mass of not less than 200-lbm (91-kg). Secure the base plate to the rigid foundation. The method of attachment to the rigid foundation shall allow easy removal of the assembled mold, collar and base plate after compaction is completed.

10.4.3 Compact the specimen in three layers. After compaction, each layer should be approximately equal in thickness. Prior to compaction, place the loose soil into the mold and spread into a layer of uniform thickness. Lightly tamp the soil prior to compaction until it is not in a fluffy or loose state, using either the manual compaction rammer or a 2-in. (50.8-mm) diameter cylinder. Following compaction of each of the first two layers, any soil adjacent to the mold walls that has not been compacted or extends above the compacted surface shall be trimmed. The trimmed soil may be included with the additional soil for the next layer. A knife or other suitable device may be used. The total amount of soil used shall be such that the third compacted layer slightly extends into the collar, but does not exceed 1/4-in. (6-mm) above the top of the mold. If the third layer does extend above the top of the mold by more than 1/4-in. (6-mm), the specimen shall be discarded. The specimen shall be discarded when the last blow on the rammer for the third layer results in the bottom of the rammer extending below the top of the compaction mold.

10.4.4 Compact each layer with 25 blows for the 4-in. (101.6-mm) mold or with 56 blows for the 6-in. (152.4-mm) mold.

NOTE 9—When compacting specimens wetter than optimum water content, uneven compacted surfaces can occur and operator judgement is required as to the average height of the specimen.

10.4.5 In operating the manual rammer, take care to avoid lifting the guide sleeve during the rammer upstroke. Hold the guide sleeve steady and within 5° of vertical. Apply the blows at a uniform rate of approximately 25 blows/min and in such a manner as to provide complete, uniform coverage of the specimen surface.

10.4.6 Following compaction of the last layer, remove the collar and base plate from the mold, except as noted in **10.4.7**. A knife may be used to trim the soil adjacent to the collar to loosen the soil from the collar before removal to avoid disrupting the soil below the top of the mold.

10.4.7 Carefully trim the compacted specimen even with the top of the mold by means of the straightedge scraped across the top of the mold to form a plane surface even with the top of the mold. Initial trimming of the specimen above the top of the mold with a knife may prevent the soil from tearing below the top of the mold. Fill any holes in the top surface with unused or trimmed soil from the specimen, press in with the fingers, and again scrape the straightedge across the top of the mold. Repeat the appropriate preceding operations on the bottom of the specimen when the mold volume was determined without the base plate. For very wet or dry soils, soil or water may be lost if the base plate is removed. For these situations, leave the base plate attached to the mold. When the base plate is left attached, the volume of the mold must be calibrated with the base plate attached to the mold rather than a plastic or glass plate as noted in **Annex A1, A1.4**.

10.4.8 Determine and record the mass of the specimen and mold to the nearest gram. When the base plate is left attached, determine and record the mass of the specimen, mold and base plate to the nearest gram.

10.4.9 Remove the material from the mold. Obtain a specimen for water content by using either the whole specimen (preferred method) or a representative portion. When the entire specimen is used, break it up to facilitate drying. Otherwise, obtain a portion by slicing the compacted specimen axially through the center and removing about 500-g of material from the cut faces. Obtain the water content in accordance with Test Method **D 2216**.

10.5 Following compaction of the last specimen, compare the wet unit weights to ensure that a desired pattern of obtaining data on each side of the optimum water content will be attained for the dry unit weight compaction curve. Plotting the wet unit weight and water content of each compacted specimen can be an aid in making the above evaluation. If the desired pattern is not obtained, additional compacted specimens will be required. Generally, one water content value wet of the water content defining the maximum wet unit weight is sufficient to ensure data on the wet side of optimum water content for the maximum dry unit weight.

11. Calculation

11.1 Calculate the dry unit weight and water content of each compacted specimen as explained in **11.3** and **11.4**. Plot the values and draw the compaction curve as a smooth curve through the points (see example, **Fig. 3**). Plot dry unit weight