



Designation: D 1185 – 98a (Reapproved 2003)

# Standard Test Methods for Pallets and Related Structures Employed in Materials Handling and Shipping<sup>1</sup>

This standard is issued under the fixed designation D 1185; the number immediately following the designation indicates the year of original adoption or, in the case of revision, the year of last revision. A number in parentheses indicates the year of last reapproval. A superscript epsilon ( $\epsilon$ ) indicates an editorial change since the last revision or reapproval.

*This standard has been approved for use by agencies of the Department of Defense.*

## 1. Scope

1.1 These test methods cover the performance of pallets and related structures, functioning as skids, bases, platforms, and bins in materials handling and shipping. Their use facilitates the protection of both packaged and unpackaged products during storage and transportation. The test methods include measurements of the relative resistance of pallets and related structures to deformations, damages, and structural failures which detrimentally affect the functionality of the unit load.

1.2 These test methods include conditioning requirements, static stiffness and strength tests, and dynamic tests of structural reliability. These test methods are used to evaluate the relative performance of new, used, or reconditioned general and special-purpose pallets fabricated from various materials including solid wood, wood composites, fiberboard, honeycomb, plastics, or metal, or to compare the performance of such pallets and related structures to specified performance criteria. Recommended criteria for all tests specified in this standard are listed in [Appendix X2](#).

1.2.1 These test methods are also used to classify pallets as single- or multiple-use pallets and to determine the safe working loads for pallets under specified load and support conditions.

1.3 *Nonmandatory Preliminary Tests*—Because each pallet may be used under several different conditions of load and support, pallet-design considerations and safe working-load estimates shall be based on that condition under which the pallet offers least resistance or is most severely stressed.

1.3.1 Preliminary, short-duration static tests up to the ultimate (see [8.2](#), [8.3](#), and [8.4](#)) shall be performed on previously

non-tested pallets to determine which load and support conditions influence most severely the pallet load-carrying capacity and safe working loads.

1.3.2 During the development of prototypes leading to designs that will be subject to acceptance testing, as described in [1.4](#), these preliminary tests shall include the free-fall drop tests in accordance with [9.1](#).

1.4 *Mandatory Acceptance Tests*:

1.4.1 *General-Purpose Pallets*—When the objective of the test is to determine the safe working load or to classify a general-purpose pallet as a single- or multiple-use pallet, all tests described in these test methods shall be performed in the order specified. The same pallet shall be used for all static and dynamic tests, where feasible.

1.4.2 *Special-Purpose Pallets*—When the objective of the test is to determine the safe working load or to classify a special-purpose pallet, as a single- or multiple-use pallet, only those tests representing the intended condition of use shall be performed. Certain special-purpose pallet designs, because of the pallet size, its shape, or the material of fabrication, or combinations thereof, cannot be reliably tested using this methodology. When available, alternative test methods should be used.

1.4.3 *Field Testing*—It is recommended that pallet designs passing these acceptance tests be further subjected to field testing in the distribution environment.

1.5 *Simulation of the Distribution Environment*—These test methods are not intended to lead to exact simulations of pallet performance in the distribution environment. These test methods are designed to relate to practice with the added provision that they are repeatable, do not depend on exceptional skills, and are safe to conduct without elaborate precautions. The test findings are not expected to lead to unalterable conclusions.

<sup>1</sup> These test methods are under the jurisdiction of ASTM Committee D10 on Packaging and are the direct responsibility of Subcommittee D10.21 on Shipping Containers and Systems—Application of Performance Test Methods.

Current edition approved Nov. 10, 1998. Published March 1999. Originally published as D 1185 – 51 T. Last previous edition D 1185 – 98.

Testing in the distribution environment may be necessary to verify the results obtained from laboratory tests.

1.6 *This standard does not purport to address all of the safety concerns, if any, associated with its use. It is the responsibility of the user of this standard to establish appropriate safety and health practices and determine the applicability of regulatory limitations prior to use.* Specific warnings are given in 9.5.3.5.

## 2. Referenced Documents

### 2.1 ASTM Standards:<sup>2</sup>

**D 642** Test Method for Determining Compressive Resistance of Shipping Containers, Components, and Unit Loads

**D 996** Terminology of Packaging and Distribution Environments

**D 999** Methods for Vibration Testing of Shipping Containers

**D 1505** Test Method for Density of Plastics by the Density-Gradient Technique

**D 1761** Test Methods for Mechanical Fasteners in Wood

**D 2395** Test Methods for Specific Gravity of Wood and Wood-Base Materials

**D 4003** Test Methods for Programmable Horizontal Impact Test for Shipping Containers and Systems

**D 4332** Practice for Conditioning Containers, Packages, or Packaging Components for Testing

**D 4442** Test Methods for Direct Moisture Content Measurement of Wood and Wood-Base Materials

**D 4444** Test Methods for Use and Calibration of Hand-Held Moisture Meters

**D 4728** Test Method for Random Vibration Testing of Shipping Containers

**F 680** Methods of Testing Nails

**F 1575** Test Method for Determining Bending Yield Moment of Nails

**F 1667** Specification for Driven Fasteners: Nails, Spikes, and Staples

### 2.2 ASME Standard:<sup>3</sup>

**MH 1** Pallets, Slipsheets, and Other Bases for Unit Loads

### 2.3 ISO Standard:<sup>3</sup>

**ISO 445** Pallets for Material Handling— Vocabulary

### 2.4 TAPPI Standard:<sup>4</sup>

**TAPPI T 208 OM - 89** Moisture in Wood, Pulp, Paper and Paper Board by Tolvene Distillation

## 3. Terminology

3.1 *Definitions*—The following standards are applicable, with Terminology **D 996**, to be considered the governing standard in the case of a dispute: Terminology **D 996**, **MH 1**, and **ISO 445**.

<sup>2</sup> For referenced ASTM standards, visit the ASTM website, www.astm.org, or contact ASTM Customer Service at service@astm.org. For Annual Book of ASTM Standards volume information, refer to the standard's Document Summary page on the ASTM website.

<sup>3</sup> Available from the American National Standards Institute, 11 West 42nd Street, 13th Floor, New York, NY 10036.

<sup>4</sup> Available from the Technical Association of the Pulp and Paper Industry, P.O. Box 105113, Atlanta, GA 30348.

3.2 *datum load*—a preload level applied to the specimen to reduce test variables as influenced by the test setup during the initial stage of testing. Test deformations shall be assumed to be zero at this preload level.

3.3 *general-purpose pallets*—pallets designed and constructed to support a wide range of loads using a variety of applicable handling devices.

3.4 *preliminary safe working load*—an estimate of the safe working load of a pallet not yet confirmed by all of the appropriate tests specified in these test methods.

3.5 *safe working load*—The maximum load, determined from tests, that a pallet can support without failure in handling, storage, and distribution including an appropriate allowance for variations in performance as well as necessary safety factors.

3.6 *special-purpose pallets*—pallets designed and constructed to support a specified load using certain handling devices.

## 4. Significance and Use

4.1 Static compression and bending tests provide data that are used to estimate stiffness, strength, and safe working loads for pallets under specified load and support conditions. These estimates provide a basis for designing pallets and comparing the performance between pallets of different designs and constructions.

4.2 Dynamic tests provide data which are used to estimate the physical durability and functionality of a pallet in specified material handling and shipping environments. These estimates provide a basis for designing single or multiple-use pallets.

4.3 Other tests may be performed to assess the properties of specific materials (Test Methods **D 2395**, **D 4442**, **D 4444**, and **T 208 OM**) and connecting devices (Test Methods **D 1761**, **F 680**, Test Method **F 1575**, and Specification **F 1667**), design features, use applications, and other variables encountered.

## 5. Materials

5.1 These test methods are pertinent to pallets constructed of materials listed in **Table 1**.

## 6. Sampling

6.1 Sampling shall provide for the selection of representative specimens. The number of test replications required varies. At least three replications per pallet design shall be tested.

## 7. Conditioning

7.1 Some pallets are constructed of materials whose properties are affected by changes in temperature, relative humidity, and environmental moisture conditions prior to and during use in the distribution environment. Prior to test, these pallets shall be conditioned as described in **Table 1**.

7.2 Where conditioning influences pallet performance, the specified test-specimen environment shall exist during the time of testing. If the test environment cannot be maintained at the required conditioning level, the tests shall be performed immediately after the pallet has been removed from the conditioning environment. Immediately after each individual test, specimens subjected to Environments A or B shall be returned to the conditioning environment for a minimum of 1

TABLE 1 Conditioning and Testing Environments

Conditioning Environment	Temperature, °C	Relative Humidity, %	Minimum Conditioning Time, h	Pallet Material
	no conditioning required			unprocessed sawn wood assembled with metal connectors <sup>A,B</sup> metals
A	+60 ± 2 <sup>C</sup>	...	24	plastics <sup>B</sup>
B	-25 ± 3	...	...	
C	25 ± 3	90 ± 5	48	paper-based materials, wood assembled with adhesives, and processed wood (that is, plywood, strandboard, particle board, and other wood based materials). <sup>D</sup>
D	20 ± 5	...	24	

<sup>A</sup> The moisture content of unprocessed sawn wood components shall represent the maximum that would occur during the use of the pallet.

<sup>B</sup> Special purpose pallets may be conditioned to temperatures reflecting anticipated use conditions.

<sup>C</sup> 45°C shall be the temperature used for 8.4, Pallet Bending Tests.

<sup>D</sup> Environment D shall be used for pallets made of these materials when it is expected that the pallets may be exposed to water in the distribution environment.

h prior to the next test. For additional details concerning conditioning procedures, see Practice D 4332.

7.3 For wood or wood-base materials, the moisture content of selected components shall be observed and recorded at the beginning of the test (see Test Methods D 4442 and D 4444).

7.4 Pallets fabricated of several different materials, such as composites, shall be conditioned to the extremes applicable to the materials in the structure.

STATIC TESTS

8. Summary of Test Method

8.1 Static tests are performed to determine the strength and stiffness of the pallet under specified load and support conditions. For all static tests described in 8.3-8.5, the test load applied shall include the mass of all load applicators supported by the pallet. The performance criteria in X2.1 of Appendix X2 may be used to determine the safe working load of a pallet (see 1.2.1 and 1.4).

8.2 Apparatus:

8.2.1 *Calibrated Compression Testing Machine*, with sufficient load capacity to structurally fail the pallet and a sufficiently large bed to support the pallet and the pallet supports (see 8.3.2).

8.2.2 *Floating Head*, used for application of rigid loads.

8.2.3 *Fixed Head*, used for supporting load at prescribed angles (see 8.4.1).

8.2.4 *“Dead Weights”* simulate the desired load, used instead of a testing machine. These dead weights shall conform to the description in 8.4.1.

8.2.5 Deformations shall be monitored and recorded using micrometer dial gages or other suitable measuring devices, such as calibrated sensors, capable of measuring deformation or deflection of 0.025 mm (0.001 in.).

8.2.6 *Calibration and Standardization of the Compression Test Apparatus*—The accuracy of the compression testing device shall be verified using procedures described in Test Method D 642.

8.3 *Compression Tests on Pallet Deck Spacers or Supports*—The purpose of this test is to determine the resistance to compression of deck spacers (stringers, blocks, and posts) of pallets.

8.3.1 *Deformation Measurements*—When tested in accordance with the procedure specified in 8.3.2, record the change

in the height, *y*, at Locations A, B, C, and D, as shown in Fig. 1, relative to the ground (or test frame), (1) at the datum load (see 8.3.2 and 3.1); (2) at the beginning and end of the full-load period; and (3) upon unloading, at the datum load (see 8.3.2), every 5 min until successive readings are practically identical (limited to a maximum period of 1 h).

8.3.1.1 When, due to test procedure, the deflections at Locations A, B, C, and D are not identical, the average of the four observations shall be used as the test measure (see Fig. 1).

8.3.2 Test Procedure:

8.3.2.1 Place the pallet in a normal position on a flat, hard, rigid, and horizontal surface. Place a rigid load applicator of sufficient size to overlap the pallet edges and ends, as shown in Fig. 1.

8.3.2.2 Gradually apply the test load at a uniform rate of 0.5 ± 0.1 in./min from 0 to 0.10 *R*, where *R* is the preliminary safe working load based on the preliminary test or on that determined from tests to failure. This value of 0.10 *R* shall be the datum load for subsequent deflection measurements (see Note 1). Apply the full test load of 1.1·*M*·*R*, where *M* is the maximum number of pallet loads expected in a stack during use. The datum as well as the full test loads shall be applied in not less than 1 min or more than 5 min. Maintain the full test load for a period of at least 24 h. Reduce the test load to the

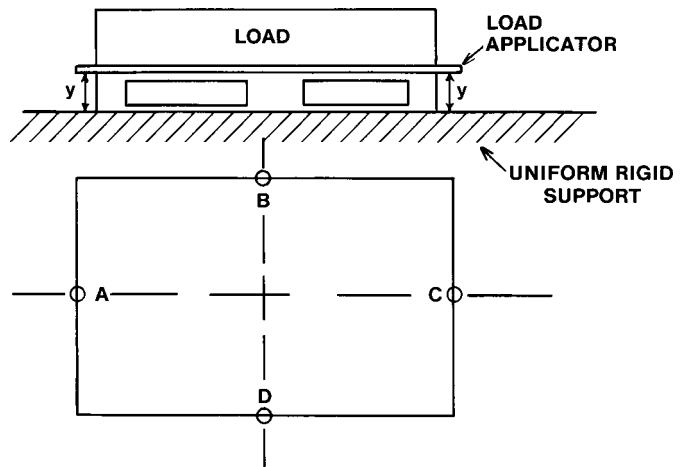

FIG. 1 Load and Support Conditions and Locations of Deflection Measurements for Compression Tests of Pallet Deck Spacers or Supports

datum load for the necessary period (see 8.3.1). Take deflection measurements at A, B, C, and D (see Fig. 1).

NOTE 1—For plastic, corrugated paperboard, or honeycomb pallets, datum load levels of 100 to 200 lbf are recommended.

8.3.2.3 If because of the unavailability of a suitable testing machine, dead weights are used for the test load, they shall be symmetrically placed during loading and unloading. Dead weights shall be carefully placed, without dropping, within a 1 to 5-min loading period.

8.3.2.4 An alternative to the full pallet compression test is the test of an individual spacer as in block or post pallets or a portion of the spacer as in stringer pallets (see Fig. 2). The datum load shall be adjusted by the ratio of the bearing area of the individual spacers or portions of spacers tested and the bearing area of all spacers in the pallet. For non-uniform loading, only the most severely stressed spacers shall be tested.

8.3.2.5 The average of the deflections measured at  $A_1$  and  $A_2$  shall be used (see Fig. 2). When testing only a portion of the pallet, at least three tests shall be performed at different locations of the pallet, such as at A, B, and C in Fig. 2.

8.3.2.6 Observe and record any structural damage or failures. The pallet has failed the test if the observed damage in any pallet tested would affect pallet stiffness, strength, or functionality. The rate of deformation is expected to decrease during the full-load static test.

8.3.2.7 During preliminary testing and to determine the preliminary safe working load  $R$  (see Table X2.1), this test shall be continued to a load level causing structural failure. In such a case, the failed pallet is no longer suitable for use in sequential testing.

8.4 *Bending Tests on Pallet*—The purpose of this test is to determine the flexural stiffness and strength of the whole pallet.

8.4.1 *Test Loads*—Typical representative loads (case goods, bagged goods, blocks, barrels, etc.) shall be used in pallet bending tests. Where various loads will be placed on pallets, that load type resulting in the greatest stress shall be used. When actual loads cannot be used, simulated loads are acceptable. Uniformly distributed case goods or bag loads are simulated using an inflatable bag or a tube restrained in a testing rig or by using a vacuum chamber.<sup>5</sup> Concentrated loads on pallets are simulated with load applications exhibiting the same geometric interface between the load and the pallet deck as the actual in-service load.

8.4.2 *Supports*—Placement of rigid supports for pallet bending tests shall be based on the mode of support during use. When more than one mode of support is likely to occur, that which most limits the functionality of the pallet under load shall be used for testing. That support which limits pallet functionality in bending shall be used which causes greatest deflection or structural failure at the lowest load levels. This is typically the support that results in the greatest unsupported free span. Support modes are shown in Fig. 3 and described as follows:

8.4.2.1 *Fork-Tine Support*—Under the top deck or in the stringer notch in stringer pallets.

8.4.2.2 *Rack Support*—Under the bottom deck or outside of the deck spacers in wing pallets.

<sup>5</sup> Pallet device incorporating an inflatable dunnage bag is described in: Mackes, K. H., Loferski, J. R., and White, M. S., A Pneumatic Pressure Bag Testing Machine for Applying a Uniform Load to Panels and Pallets, *Journal of Testing and Evaluation*, Vol. 23, No. 4, 1995, pp. 295-299. A test device incorporating a vacuum chamber is described in: Dallas, J. E., and Mitzner, R. C., "Vacuum Loading Technique Increases Accuracy of Pallet Testing," Technical Note, *Forest Products Journal*, 1985, Vol. 27, pp 48-50.

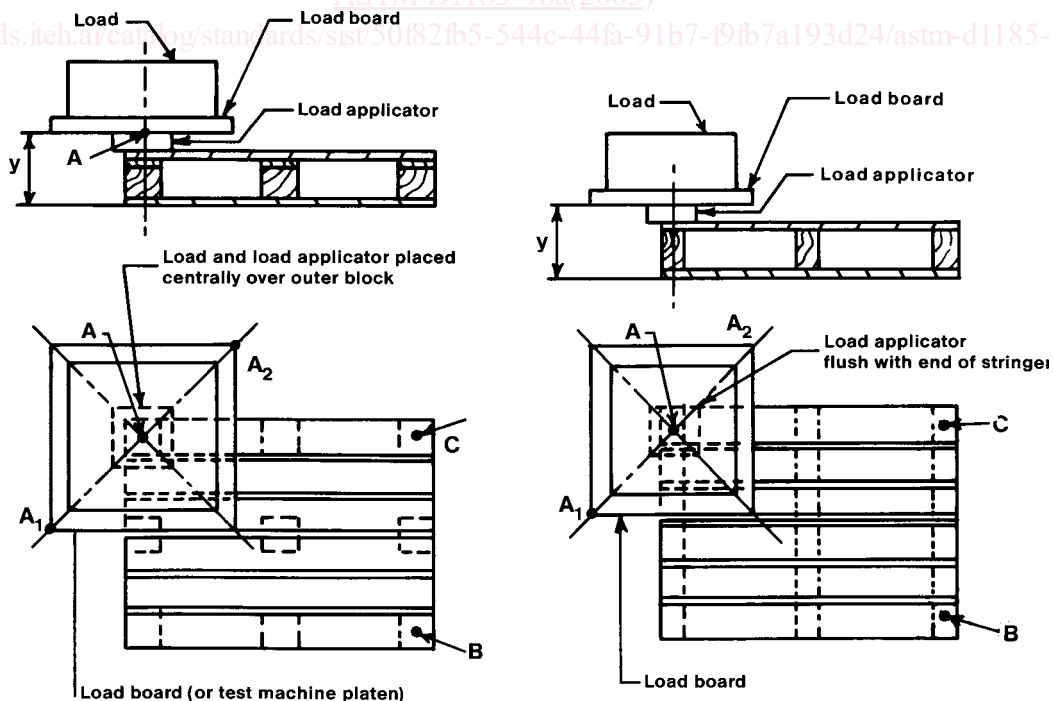

FIG. 2 Load Application and Deflection-Measurement Locations for Compression Tests of Individual Pallet-Deck Spacers or Portions of Spacers

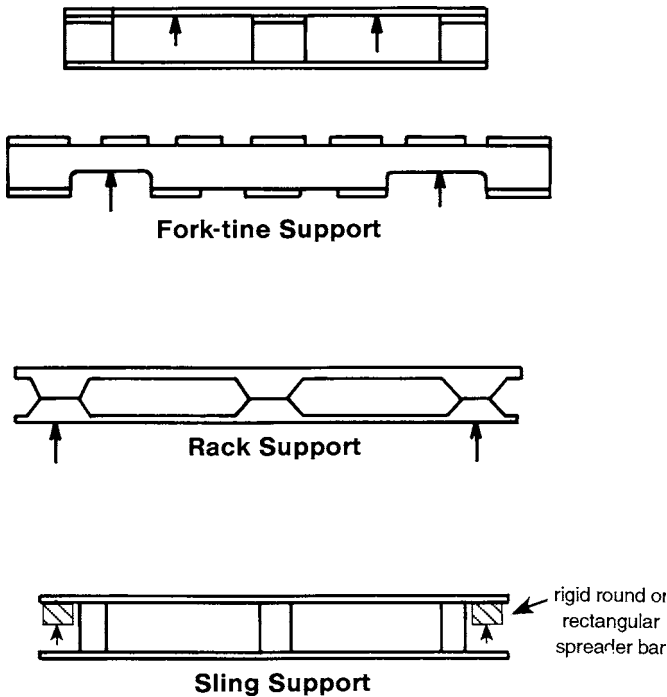

FIG. 3 Support Modes for Static Pallet-Bending Test

8.4.2.3 *Sling Support*—Under the top deck, outside of the deck spacers such as in wing pallets. For sling tests, support modes shall be determined by the intended distribution cycle and the sling equipment used in that distribution environment.

(Test devices may include wire, tape, or chain slings and rigid, round, or rectangular spreader bars.)

8.4.2.4 With the exception of very long or wide pallets, which exhibit large cantilevers beyond the supports, the rack mode generally represents the greatest span and corresponding deflection.

8.4.3 *Deformation Measurements*—When tested in accordance with the method specified in 8.4.4, the deflection at Locations A, B, and C, as shown in Fig. 4, when measured relative to the upper (or lower) surface of the top (or bottom) decks and the ground (or test frame), shall be observed and recorded as follows:

8.4.3.1 At the datum load (see 8.4.4),

8.4.3.2 Upon unloading, at the datum load (see 8.4.4), every 5 min until successive readings are practically identical (limited to a maximum period of 1 h).

8.4.3.3 The distance between the decks,  $h$ , at mid-span between deck spacers, measured in order to obtain data on the minimum fork entry heights under given loads.

8.4.3.4 Between the decks, similar measurements made at Locations C, D, and E when the test is repeated along the second horizontal axis of the pallet (see 8.4.4).

8.4.4 *Test Procedure:*

8.4.4.1 For most pallets stressed in bending, the support mode which limits functionality is the rack support or the support under the bottom deck in double-face pallets or under the top deck in single-face pallets. Under these conditions of support, place the pallet top deck uppermost on rigid support beams with square or semicircular cross section. If the span

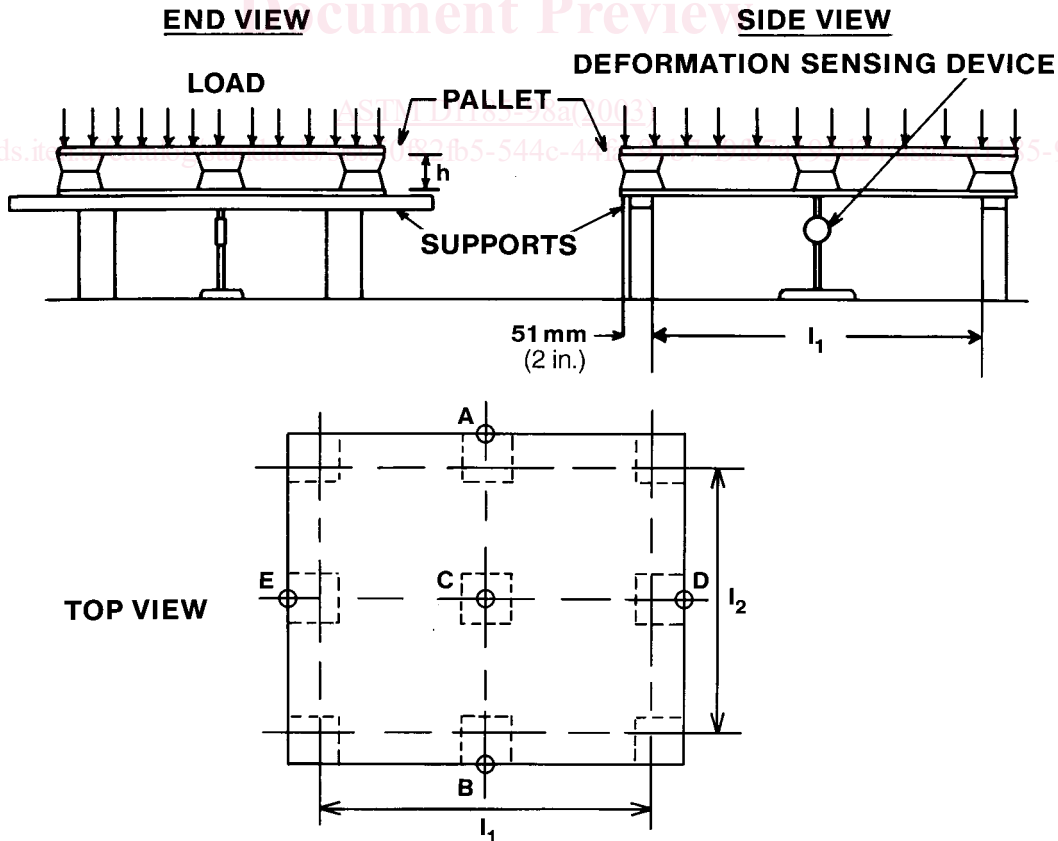

FIG. 4 Schematic Diagram of Pallet Bending Test Using Uniformly Distributed Load

between the supports is unknown, place the inside edges of the supports (or centerline in semicircular cross-section supports) 51 mm (2 in.) from the outer edges of the pallet (see Fig. 4).

8.4.4.2 Gradually apply the test load at a uniform rate from 0 to 0.1  $R$ , where  $R$  is the preliminary safe working load per pallet and 0.1  $R$  is the datum load for subsequent deflection measurements. Apply the full test load of 1.25· $M$ · $R$ , where  $M$  is the maximum number of pallet loads expected when supported or tested. Maintain the full test load for a period of at least 24 h.

8.4.4.3 Reduce the test load to the datum load for the necessary period (see 8.4.3) and observe the deflection measurements at Locations A, B, and C (see Fig. 4).

8.4.4.4 If, because of the unavailability of a suitable testing machine, dead weights are used for the test load, they shall be symmetrically placed during loading and unloading. Dead weights shall be carefully placed, without dropping, and within a 1 to 5-min loading period.

8.4.4.5 Repeat the test along the second horizontal axis of the pallet (that is, when both length and width are to be tested). A further set of deflection measurements shall be taken at Locations C, D, and E. Observe and record any damage and structural failure. The pallet has failed the test if the observed damage in any pallet tested affects pallet stiffness, strength, or functionality. The rate of deformation is expected to decrease during the full-load static test.

8.4.4.6 During preliminary testing and to determine the preliminary safe working load  $R$  (see Table X2.1), this test shall be continued to a load level causing structural failure. In such a case, the failed pallet shall not be used for further testing.

8.5 *Bending Tests on Pallet Decks*—Under certain load and support conditions, the flexural stiffness and strength of the pallet top or bottom deck limits functionality. The purpose of this test is to determine the stiffness and flexural strength of pallet decks between supports.

8.5.1 *Deflection Measurements:*

8.5.1.1 When tested in accordance with 8.5.2, deflection shall be measured in a minimum of two locations at mid-span of the longest span between deck spacers, such as at Locations A, B, C, and D in Fig. 5, or at the location of the concentrated loads.

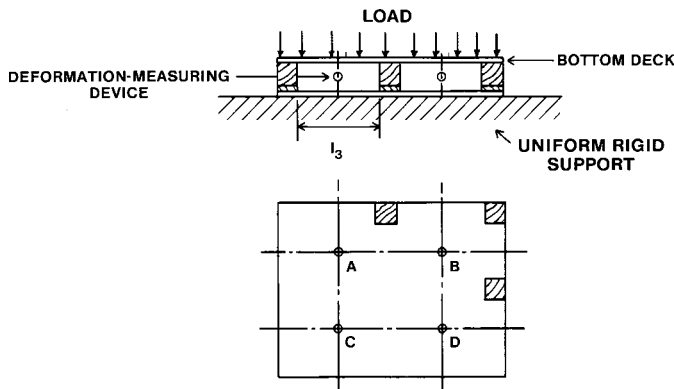

FIG. 5 Load and Support Conditions and Locations of Deflection Measurements for Bending Test of Pallet Decks

8.5.1.2 Measurements relative to the upper or lower surface of the deck and the opposite deck or the ground (or test frame), shall be recorded as follows:

- (1) At the datum load (see 8.5.2);
- (2) At the beginning and end of the full load period;
- (3) Upon unloading, at the datum load (see 8.4.3), every 5 min until successive readings are practically identical:

8.5.2 *Test Procedure:*

8.5.2.1 Gradually apply the test load at a uniform rate from 0 to 0.1  $R$  in a 1 to 5-min loading period. This shall be the datum load for subsequent deflection measurements. Apply the full test load of 1.15· $M$ · $R$  for the top deck and 1.15·( $M$ – 1)· $R$  for the bottom deck of non-reversible pallets, if load effects on pallets in the stack are cumulative, in not less than 1 min and not more than 5 min.  $R$  is the preliminary safe working load per pallet and  $M$  is the maximum number of pallet loads expected in a stack during use. The datum as well as the full test load shall be applied in not less than 1 min or more than 5 min. Maintain the full test load in place for a period of at least 24 h.

8.5.2.2 Reduce the test load to the datum load for the necessary period (see 8.5.1) and take the deflection measurements at Locations A, B, C, and D. This test shall be repeated for both decks of a double-face pallet. Observe and record any damage or structural failures. The pallet has failed the test if the observed damage in any pallet tested affects pallet stiffness, strength, or functionality. The rate of deformation is expected to decrease during the test.

8.5.2.3 If, because of unavailability of a suitable testing machine, dead weights are used for the test load, they shall be symmetrically placed during loading and unloading. Dead weights shall be carefully placed, without dropping, and within a 2 to 5-min loading period.

8.5.2.4 During preliminary testing and the determination of the preliminary safe working load  $R$  (see Table X2.1), this test shall be continued to a load level causing structural failure. In such a case, the failed pallet shall not be used for further testing.

DYNAMIC TESTS

9. Summary of Test Method

9.1 Dynamic tests are performed to determine the stability of the pallet and unit load on the pallet when exposed to elements of the handling and shipping environments. These tests shall be sequentially performed in the order described and each represents one hazard element. A hazard element is a specific event that occurs in the distribution cycle that may pose a hazard to the pallet and the unit load. If any deviations are made from this sequence to meet specific requirements or limitations, they shall be indicated and explained in the report.

9.2 For the dynamic tests described in 9.5, the test load applied shall include the actual package systems unitized similar to the expected unit load. In the case where representative actual products cannot be used, dummy products that are similar in size and weight shall be used. However, the packaging used shall be identical to that of real loads, since the dynamics of the unit load is affected if a dead load representing