



Designation: D 1434 – 82 (Reapproved 2003)

Standard Test Method for Determining Gas Permeability Characteristics of Plastic Film and Sheeting¹

This standard is issued under the fixed designation D 1434; the number immediately following the designation indicates the year of original adoption or, in the case of revision, the year of last revision. A number in parentheses indicates the year of last reapproval. A superscript epsilon (ϵ) indicates an editorial change since the last revision or reapproval.

1. Scope

1.1 This test method covers the estimation of the steady-state rate of transmission of a gas through plastics in the form of film, sheeting, laminates, and plastic-coated papers or fabrics. This test method provides for the determination of (1) gas transmission rate (GTR), (2) permeance, and, in the case of homogeneous materials, (3) permeability.

1.2 Two procedures are provided:

1.2.1 *Procedure M*— Manometric.

1.2.2 *Procedure V*— Volumetric.

1.3 The values stated in SI units are to be regarded as the standard.

1.4 *This standard does not purport to address all of the safety concerns, if any, associated with its use. It is the responsibility of the user of this standard to establish appropriate safety and health practices and determine the applicability of regulatory limitations prior to use.*

2. Referenced Documents

2.1 *ASTM Standards:*²

D 618 Practice for Conditioning Plastics for Testing

D 1898 Practice for Sampling of Plastics³

3. Terminology

3.1 *Definitions of Terms Specific to This Standard:*

3.1.1 *gas transmission rate, GTR*— the quantity of a given gas passing through a unit of the parallel surfaces of a plastic film in unit time under the conditions of test. The SI unit of GTR is $1 \text{ mol}/(\text{m}^2 \cdot \text{s})$. The test conditions, including temperature and partial pressure of the gas on both sides of the film, must be stated. Other factors, such as relative humidity and hydrostatic pressure, that influence the transport of the gas must also be stated. The inch-pound unit of GTR, a commonly

used unit of GTR, is $1 \text{ mL (STP)}/(\text{m}^2 \cdot \text{d})$ at a pressure differential of one atmosphere.

3.1.2 *permeance, P*—the ratio of the gas transmission rate to the difference in partial pressure of the gas on the two sides of the film. The SI unit of permeance is $1 \text{ mol}/(\text{m}^2 \cdot \text{s} \cdot \text{Pa})$. The test conditions (see 5.1) must be stated.

3.1.3 *permeability, P*—the product of the permeance and the thickness of a film. The permeability is meaningful only for homogeneous materials, in which it is a property characteristic of the bulk material. This quantity should not be used unless the constancy of the permeability has been verified using several different thicknesses of the material. The SI unit of P is $1 \text{ mol}/(\text{m} \cdot \text{s} \cdot \text{Pa})$. The test conditions (see 3.1) must be stated.

NOTE 1—One millilitre (STP) is $44.62 \mu\text{mol}$, one atmosphere is 0.1013 MPa , and one day is $86.4 \times 10^3 \text{ s}$. GTR in SI units is obtained by multiplying the value in inch-pound units by 5.160×10^{-10} . Additional units and conversions are shown in Appendix X1.

3.1.4 *steady state*—the state attained when the amount of gas absorbed in the film is in equilibrium with the flux of gas through the film. For Method V this is obtained when the GTR is constant.

4. Summary of Test Method

4.1 The sample is mounted in a gas transmission cell so as to form a sealed semibarrier between two chambers. One chamber contains the test gas at a specific high pressure, and the other chamber, at a lower pressure, receives the permeating gas. Either of the following procedures is used:

4.1.1 *Procedure M*— In Procedure M the lower pressure chamber is initially evacuated and the transmission of the gas through the test specimen is indicated by an increase in pressure.

4.1.2 *Procedure V*— In Procedure V the lower pressure chamber is maintained near atmospheric pressure and the transmission of the gas through the test specimen is indicated by a change in volume.

5. Significance and Use

5.1 These measurements give semiquantitative estimates for the gas transmission of single pure gases through film and sheeting. Correlation of measured values with any given use, such as packaged contents protection, must be determined by

¹ This test method is under the jurisdiction of ASTM Committee F02 on Flexible Barrier Materials and is the direct responsibility of Subcommittee F02.10 on Permeation.

Current edition approved July 30, 1982. Published November 1982. Originally published as D 1434 – 56 T. Last previous edition D 1434 – 75.

² For referenced ASTM standards, visit the ASTM website, www.astm.org, or contact ASTM Customer Service at service@astm.org. For Annual Book of ASTM Standards volume information, refer to the standard's Document Summary page on the ASTM website.

³ Withdrawn.

experience. The gas transmission rate is affected by conditions not specifically provided for in these tests, such as moisture content (Note 2), plasticizer content, and nonhomogeneities. These tests do not include any provision for testing seals that may be involved in packaging applications.

NOTE 2—The tests are run using gas with 0 % moisture changes.

5.2 Interlaboratory testing has revealed that permeances measured by these procedures exhibit a strong dependence on the procedure being used, as well as on the laboratory performing the testing. Agreement with other methods is sometimes poor and may be material-dependent. The materials being tested often affect the between-laboratory precision. The causes of these variations are not known at this time. It is suggested that this method not be used for referee purposes unless purchaser and seller can both establish that they are measuring the same quantity to a mutually agreed upon level of precision.

5.3 Use of the permeability coefficient (involving conversion of the gas transmission rate to a unit thickness basis) is not recommended unless the thickness-to-transmission rate relationship is known from previous studies. Even in essentially homogeneous structures, variations in morphology (as indicated, for example, by density) and thermal history may influence permeability.

6. Test Specimen

6.1 The test specimen shall be representative of the material, free of wrinkles, creases, pinholes, and other imperfections, and shall be of uniform thickness. The test specimen shall be cut to an appropriate size (generally circular) to fit the test cell.

6.2 The thickness of the specimen shall be measured to the nearest 2.5 μm (0.1 mil) with a calibrated dial gage (or equivalent) at a minimum of five points distributed over the entire test area. Maximum, minimum, and average values should be recorded. An alternative measure of thickness involving the weighing of a known area of specimens having a known density is also suitable for homogeneous materials.

7. Conditioning

7.1 *Standard Conditioning*—Condition all test specimens at $23 \pm 2^\circ\text{C}$ ($73.4 \pm 3.6^\circ\text{F}$) in a desiccator over calcium chloride or other suitable desiccant for not less than 48 h prior to test in accordance with Practice D 618, for those tests where conditioning is required. In cases of disagreement, the tolerances shall be $\pm 1^\circ\text{C}$ ($\pm 1.8^\circ\text{F}$).

7.2 *Alternative Conditioning*—Alternatives to 7.1 may be used for conditioning the specimens provided that these conditions are described in the report.

8. Sampling

8.1 The techniques used in sampling a batch of material to be tested by these procedures must depend upon the kind of information that is sought. Care should be taken to ensure that samples represent conditions across the width and along the length of rolls of film. Practice D 1898 provides guidelines for deciding what procedures to use in sampling a batch of



FIG. 1 Manometric Gas Transmission Cell

material. Enough specimens must be tested to ensure that the information obtained is representative of the batch or other lot size being tested.

PROCEDURE M

(Pressure changes in the manometric cell may be determined by either visual or automatic recording.)

MANOMETRIC VISUAL DETERMINATION

9. Apparatus

9.1 The apparatus shown in Fig. 1 and Fig. 2 consists of the following items:⁴

9.1.1 *Cell Manometer System*—The calibrated cell manometer leg, which indicates the pressure of transmitted gas, shall consist of precision-bore glass capillary tubing at least 65 mm long with an inside diameter of 1.5 mm.

9.1.2 *Cell Reservoir System*, consisting of a glass reservoir of sufficient size to contain all the mercury required in the cell.

9.1.3 *Adapters*—Solid and hollow adapters for measurement of widely varying gas transmission rates. The solid adapter provides a minimum void volume for slow transmission rates. The hollow adapter increases the void volume by about a factor of eight for faster transmission rates.

9.1.4 *Cell Vacuum Valve*, capable of maintaining a vacuum-tight seal.⁵

9.1.5 *Plate Surfaces*, that contact the specimen and filter paper shall be smooth and flat.

9.1.6 *O-Ring*, for sealing the upper and lower plates.

9.1.7 *Pressure Gage*, mechanical or electrical type with a range from 0 to 333 kPa absolute. Used for measuring upstream gas pressure.

9.1.8 *Barometer*, suitable for measuring the pressure of the atmosphere to the nearest 133 Pa.

⁴ The Dow gas transmission cell supplied by Custom Scientific Instruments, Inc., Whippany, NJ, has been found satisfactory for this purpose.

⁵ The Demi-G Valve (1/4-in. IPS) manufactured by G. W. Dahl Co., Inc., Bristol, RI, or a precision-ground glass stopcock, meets this requirement.

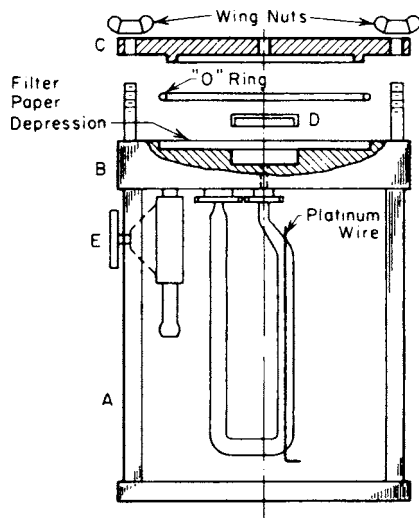

A—Supporting Legs
B—Lower Plate
C—Upper Plate
D—Adapter
E—Vacuum Valve

FIG. 2 Schematic View of Gas Transmission Cell

9.1.9 *Vacuum Gage*, to register the pressure during evacuation of the system to the nearest 13 Pa.

9.1.10 *Vacuum Pump*, capable of reducing the pressure in the system to 26 Pa or less.

9.1.11 *Needle Valve*, for slowly admitting and adjusting the pressure of the test gas.

9.1.12 *Cathetometer*, to measure the height of mercury in the cell manometer leg accurately. This instrument should be capable of measuring changes to the nearest 0.5 mm.

9.1.13 *Micrometer*, to measure specimen thickness, graduated to 2.5 μm (0.1 mil) or better.

9.1.14 *Elevated-Temperature Fittings*—Special cell fittings are required for high-temperature testing.

10. Materials

10.1 *Test Gas*—The test gas shall be dry and pure. The ratio of the volume of gas available for transmission to the volume of gas transmitted at the completion of the test shall be at least 100:1.

10.2 *Mercury*—Mercury used in the cell shall be triple distilled, checked regularly for purity, and replaced with clean mercury when necessary.

10.2.1 *Warning*—Very low concentrations of mercury vapor in the air are known to be hazardous. Guidelines for using mercury in the laboratory have been published by Steere.⁶ Be sure to collect all spilled mercury in a closed container. Transfers of mercury should be made over a large plastic tray. Under normal daily laboratory-use conditions, the cells should be cleaned about every 3 months. Dirty mercury is indicated when the drop of the capillary becomes erratic or when mercury clings to the side of the capillary, or both. Whenever

⁶ Steere, N. E. "Mercury Vapor Hazards and Control Measures" in Handbook of Laboratory Safety, N. V. Steere, Ed., CRC Press Inc., Boca Raton, FL, 1979.

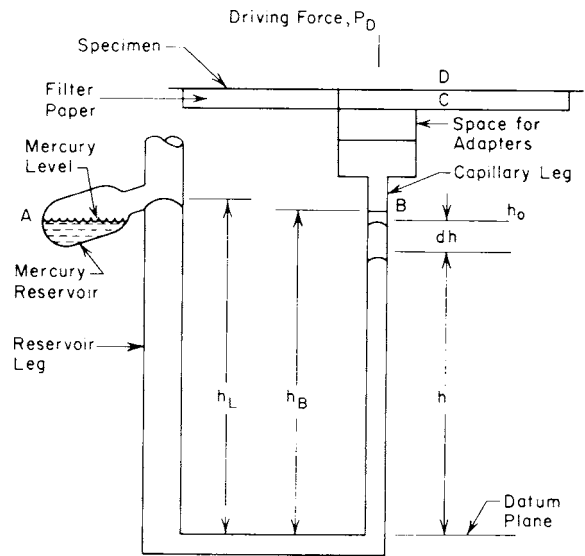

FIG. 3 Cell Manometer with Test Specimen in Place

such discontinuities occur, the mercury should be removed and the cell cleaned as follows:

- (1) Wash with toluene (to remove greases and oils).
- (2) Wash with acetone (to remove toluene).
- (3) Wash with distilled water (to remove acetone).
- (4) Wash with a 1 + 1 mixture of nitric acid and distilled water (to remove any mercury salts that may be present). This operation may be repeated if necessary in order to ensure complete cleaning of glassware.
- (5) Wash with distilled water (to remove nitric acid).
- (6) Wash with acetone (to remove water).
- (7) Dry the cell at room temperature or by blowing a small amount of clean dry air through it.

11. Calibration

11.1 Each cell should be calibrated at the test temperature as follows (Fig. 3):

11.1.1 Determine the void volume of the filter paper from the absolute density of its fiber content (Note 3), the weight of the filter paper, and its apparent volume (Note 4). Express the void volume determined in this way in microlitres and designate as V_{CD} .

NOTE 3—Any high-grade, medium-retention qualitative nonashing cel-
lulosic filter paper, 90 mm in diameter will be satisfactory for this purpose.
Cellulose fiber has an approximate density of 1.45 g/mL.

NOTE 4—The apparent volume may be calculated from the thickness and diameter of the filter paper.

11.1.2 Determine the volume of the cell manometer leg from B to C, Fig. 3, by mercury displacement. (Since the void volume of the adapters is included in this part of the calibration, the volume from B to C should be determined twice, once with the solid adapter in place, and once with the hollow.) This volume is obtained by dividing the weight of the mercury displaced by its density (Note 5). Determine this volume to nearest 1 μL and designate as V_{BC} .

NOTE 5—The density of mercury at 23°C is 13.54 g/mL.

11.1.3 Determine the volume, in microlitres, of the cell manometer leg from A to B, Fig. 3, by mercury displacement.

Determine the average cross-sectional area of the capillary by dividing this volume by the length (expressed to the nearest 0.1 mm) from *A* to *B*. Determine this area to the nearest 0.01 mm² and designate as *a_c*.

11.1.4 Determine the area of the filter paper cavity to the nearest 1 mm². Designate this area as *A*, the area of transmission.

11.1.5 Pour the mercury from the reservoir into the manometer of the cell by carefully tipping the cell. Record the distance from the datum plane to the upper calibration line *B* in the capillary leg as *h_B*. Record the distance from the datum plane to the top of the mercury meniscus in the reservoir leg as *h_L*. Determine *h_B* and *h_L* to the nearest 0.5 mm.

11.2 NBS Standard Reference Material 1470⁷ is a polyester film whose permeance to oxygen gas has been certified for a range of experimental conditions. The calibration steps in 11.1 can be verified by comparing measurements obtained using this method of test in the user's laboratory with the values provided on the certificate accompanying the SRM.

12. Procedure

12.1 Transfer all the mercury into the reservoir of the cell manometer system by carefully tipping the cell in such a way that the mercury pours into the reservoir.

12.2 Insert the appropriate adapter in the cell body.

12.3 Center a filter paper in the lower plate cavity.

12.4 Apply a light coating of vacuum grease on the flat metal that the surface of the specimen will contact. Avoid excessive grease.

12.5 Place the conditioned specimen smoothly on the lower lightly greased plate so that it covers the filter paper and the entire exposed face of the lower plate.

12.6 Locate the O-ring on the upper plate; then carefully position this plate over the specimen and fix the plate with uniform pressure to ensure a vacuum-tight seal.

12.7 Connect the line in which the test gas will be subsequently admitted to the upper plate. (The entire cell is now directly connected to the test gas line.)

12.8 Connect the vacuum source to the nipple attached to the cell vacuum valve. Evacuate the bottom of the cell; then, with the bottom still being evacuated, evacuate the top of the cell. Close off the vacuum line to the top of the cell; then close the line to the bottom (Fig. 4).

12.9 Flush the connecting line and the top of the chamber with test gas.

12.10 Reevacuate the system in the same manner as 12.8. The cell manometer system should be evacuated to a pressure of 26 Pa or less, as indicated on the vacuum gage.

12.11 Pour mercury from the reservoir into the manometer system of the cell by carefully tipping the cell. The height of the mercury in the capillary leg should be at approximately the same level as line *B* (Fig. 3) and stationary.

NOTE 6—A leak is indicated if the height of the mercury does not remain stationary. If such a leak occurs, discontinue the test and repeat the

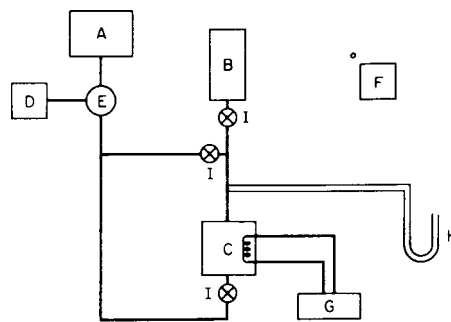

A—Vacuum Pump
B—Test Gas Cylinders
C—Gas Transmission Cell
D—Vacuum Gage
E—Trap
F—Barometer
G—Automatic Recorder (Optional)
H—Mercury Manometer
I—Needle Valve

FIG. 4 Component Arrangement of Gas Transmission Equipment

entire procedure. (If a leak occurs on a second trial, this may indicate a mechanical failure of the equipment.)

12.12 Record the height of the mercury in the capillary leg, *h_o*, at the start of each test, that is, immediately before the test gas has been admitted to the top of the cell.

12.13 After a suitable estimated time for attaining steady-state conditions, record the height of the mercury in the capillary leg, *h_o*, to the nearest 0.5 mm and the elapsed time, *t_o*, to the nearest 1 min.

12.14 Record the height of the mercury, *h*, in the capillary leg to the nearest 0.5 mm versus time, *t*, in hours, to the nearest 1 min. Take several readings (at least six are recommended) during the test. Calculate the function *g(h)* for each *t* as defined in 13.1. Plot these values versus time, (*t*−*t_o*), and construct the best straight line through these points. Use any observed values of *h* and *t* for *h_o* and *t_o*, respectively, if these values are within the steady-state region. A nonlinear plot of *g(h)* versus (*t*−*t_o*) that does not pass through the origin could indicate an improper selection of *h_o* and *t_o*; a new selection should then be made by using a larger mercury depression for the initial conditions.

NOTE 7—If, after all the mercury has been displaced from the capillary, any doubt exists as to the attainment of steady state, perform a check as follows:

- (1) Return the mercury to the reservoir.
- (2) Reevacuate the bottom of the cell only, leaving the top pressurized with test gas.
- (3) Repeat 12.11, 12.13, and 12.14.

12.15 Return the mercury in the capillary leg to the reservoir by tipping the cell upon completion of the test and prior to opening the cell vacuum valve.

12.16 Remove the specimen from the cell and measure the thickness with a micrometer (Note 8). Record the average of five determinations made uniformly throughout the specimen to the nearest 2.5 μm (0.1 mil).

NOTE 8—If there is reason to believe that the specimen will expand or contract during transmission, the thickness should be measured prior to 12.5, as well as after transmission. If any change in thickness occurs, a

⁷ This material is available from the Office of Standard Reference Materials, National Bureau of Standards, Washington, DC 20234.

note to this effect shall be included with the results.

12.17 Test three specimens with each gas.

12.18 If the requirements of 12.14 are not met in the normal atmospheric pressure test, repeat the procedure at a higher (up to 304 kPa) or lower (not less than 50 kPa) test pressure.

13. Calculation

13.1 Calculate the permeance, P , in SI units from the following relationship (Note 9):

$$P = g(h)/(t - t_o) \quad (1)$$

where:

$$g(h) = -\frac{1}{ART} \left[[V_f + a(p_u + h_B - h_L)] \cdot \ln \left\{ 1 - \frac{(h_o - h)}{P_u - (h_L - h_o)} \right\} + 2a(h_o - h) \right] \quad (2)$$

- a_c = area of capillary \overline{AB} , mm²,
- A = area of transmission, cm²,
- h_o = height of mercury in the capillary leg at the start of the actual transmission run, after steady-state conditions have been attained, mm,
- h = height of mercury in cell capillary leg at any given time, mm,
- h_B = maximum height of mercury in the cell manometer leg from the datum plane to upper calibration line B , mm,
- h_L = height of mercury in cell reservoir leg from datum plane to top of mercury meniscus, mm,
- P_u = upstream pressure of gas to be transmitted,
- R = universal gas constant 8.3143×10^3 L·Pa/(mol·K),
- t_o = time at the start of the actual transmission run, h , after steady-state conditions have been attained,
- t = time, h,
- T = absolute temperature, K,
- V_{BC} = volume from B to C , μL ,
- V_{CD} = void volume of depression, μL , and
- V_f = ($V_{BC} + V_{CD}$), μL .

NOTE 9—The derivation of this equation is given in Appendix X2. Refer to Fig. 3 for location of symbols used in this equation.

13.2 A test result is defined as a single determination of the permeance of an individual sheet of material.

MANOMETRIC RECORDING DETERMINATION

14. Apparatus

14.1 The description of the apparatus is identical to that in Section 9, with the omission of 9.1.12, which does not apply in this procedure, and the addition of the following apparatus:

14.2 *Resistance-Recording Instrument*—A resistance-recording instrument suitably connected to a uniform-diameter platinum wire (Note 10) that runs the calibrated length of the cell manometer leg shall be employed to measure changes in height of the mercury in the cell manometer leg versus time. This instrument shall be capable of measuring such changes to the nearest 0.5 mm.

NOTE 10—A recommended automatic recording device (Fig. 4 shows a simplified schematic of a setup utilizing an automatic recorder) consists of

No. 44 platinum wire (with a resistance of 0.8 Ω /cm) with No. 30 tungsten leads to the glass. These are connected by means of No. 16 gage three-conductor copper wire to a suitable ten-turn potentiometer in series with a resistance recorder whose full-scale range is 10 to 15 Ω .⁸

15. Materials

15.1 Same as Section 10.

16. Calibration

16.1 Same as Section 11, but should also include the following:

16.2 The recording instrument with the cell, lead wires, and external resistance (Note 11) in series as used in the test shall be calibrated at test temperature initially and every time after a cell has been cleaned or repaired.

NOTE 11—The external resistance should be so chosen to permit complete traverse of the chart by the pen when a change in the height of mercury equal to the height of A to B occurs (Fig. 3).

16.3 The recording system shall be calibrated as follows:

16.3.1 Allow the cell to come to constant temperature at test temperature.

16.3.2 With the top of the cell removed and the vacuum valve open, pour the mercury into the cell manometer leg such that the mercury is approximately at the same level as line B (Fig. 3) and relatively stationary. Adjust the external resistance of the recorder so that the pen indicates a chart position of zero.

16.3.3 Vary the height of the mercury column and note the position indicated by the chart pen so that a plot of chart position as ordinate versus mercury height as abscissa is obtained. A straight line should result.

16.3.4 Determine the rate of chart paper travel to the nearest 2.54 mm (0.1 in.)/h.

16.4 See 11.2 for the use of NBS Standard Reference Material 1470 in checking the calibration of the permeance measuring apparatus.

17. Procedure

17.1 Same as Section 12, with the following exceptions:

17.2 Adjust the pen of the resistance recording instrument by means of the external resistance so that the pen position corresponds with the height of mercury in the capillary leg as determined in Section 16.

17.3 For best results, set the chart to run at a speed that will plot the gas transmission curve at a slope of about 45° (Note 12). Once experience is gained, the proper chart speed is easily selected.

NOTE 12—This applies only to charts that have a variable-speed drive.

18. Calculation

18.1 For several values of t (at least six are recommended), read h from the recorder chart and plot the function $g(h)$ versus t as defined in 12.14.

⁸ The Minneapolis-Honeywell Regulator Co. 60V Model 153X64W8-X-41 resistance recorder has been found satisfactory for this purpose. It is recommended that a quick-change variable speed chart drive, such as that supplied by Inscoc Co., Division of Barry Controls, Inc., Groton, MA, be installed in the recorder.

18.2 Calculate the permeance from the equations given in 13.1.

18.3 A test result is defined as the value of a single individual determination of permeance of a film.

19.2 *Precision Glass Capillaries* or manometers with various diameters (0.25, 0.50, and 1.0 mm are recommended). The glass capillaries should have a suitable U-bend to trap the manometer liquid and a standard-taper joint to fit into the cell.

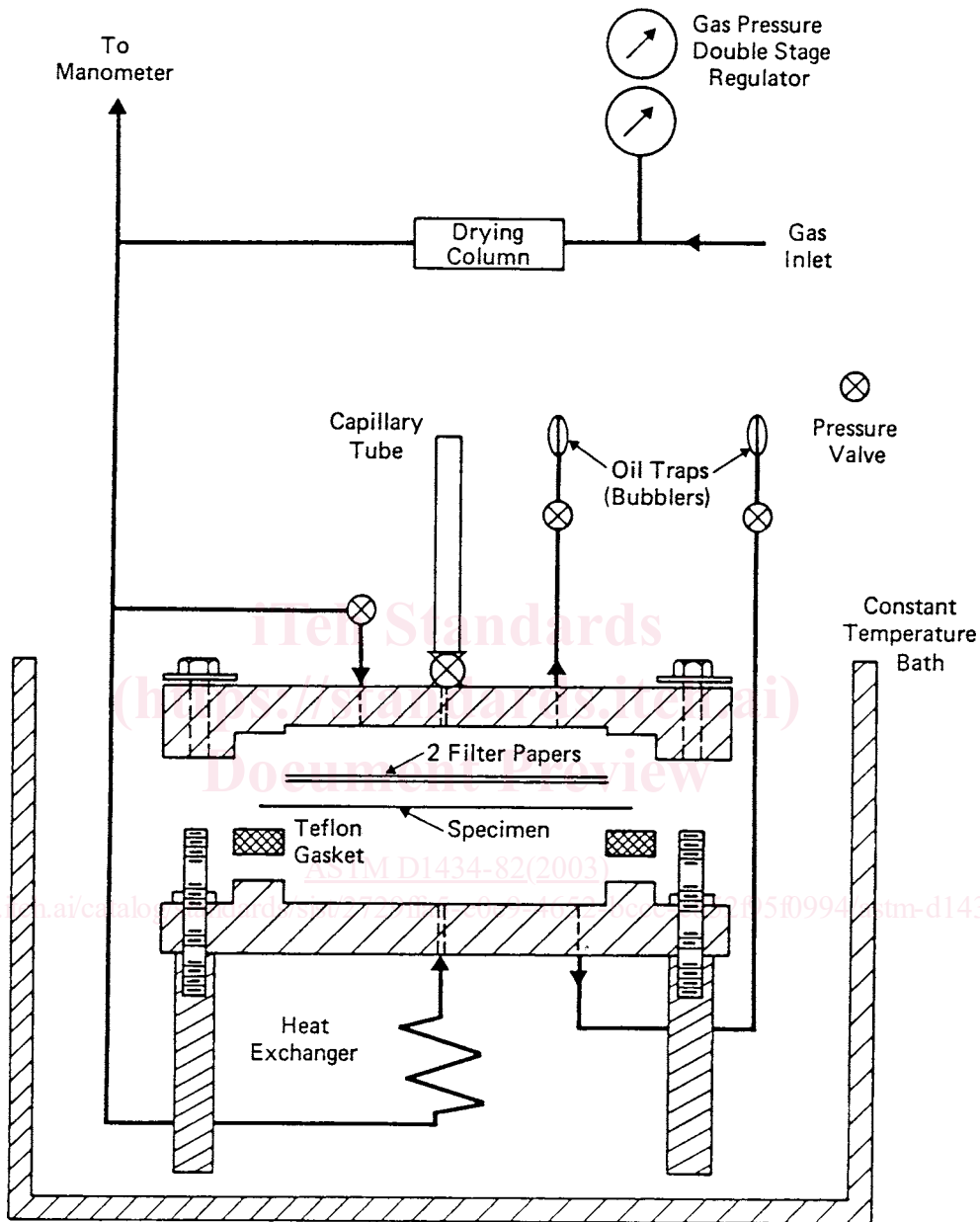

FIG. 5 Volumetric Gas Transmission Cell

PROCEDURE V

(Volumetric determinations may be made with several similar type apparatus.)

19. Apparatus

19.1 *Volumetric Gas Transmission Cell*⁹, shown in Fig. 5.

⁹ Suitable cells may be obtained from Custom Scientific Instruments, Whippany, NJ.

19.3 *Cathetometer* or suitable scale for measuring changes in meniscus position to the nearest 0.5 mm.

19.4 *Temperature Control:*

19.4.1 A temperature-control liquid bath is recommended for controlling the temperature of the cell body to $\pm 0.1^\circ\text{C}$.

19.4.2 The apparatus should be shielded to restrict the temperature variations of the capillary to $\pm 0.1^\circ\text{C}$ during the test.

19.5 *Micrometer*, to measure specimen thickness, to the nearest 2.5 μm (0.0001 in.) at a minimum of five points