



Designation: D 1084 – 97

Standard Test Methods for Viscosity of Adhesives¹

This standard is issued under the fixed designation D 1084; the number immediately following the designation indicates the year of original adoption or, in the case of revision, the year of last revision. A number in parentheses indicates the year of last reappraisal. A superscript epsilon (ϵ) indicates an editorial change since the last revision or reappraisal.

This standard has been approved for use by agencies of the Department of Defense. These test methods replace Method 4021 or Federal Test Method Standard No. 175a.

1. Scope

1.1 These test methods cover the determination of the viscosity of free-flowing adhesives.

1.1.1 The limitation of this test method to self-leveling adhesives eliminates thixotropic and plastic materials whose viscosity is a function of the rate of stirring and previous history of the adhesive.

1.2 *This standard does not purport to address all of the safety concerns, if any, associated with its use. It is the responsibility of the user of this standard to establish appropriate safety and health practices and determine the applicability of regulatory limitations prior to use.*

1.3 The values stated in SI units are to be regarded as the standard. The values in parentheses are for information only.

2. Referenced Documents

2.1 *ASTM Standards:*

D 88 Test Method for Saybolt Viscosity²

D 115 Test Methods for Varnishes Used for Electrical Insulation³

D 562 Test Method for Consistency of Paints Using the Stormer Viscometer⁴

D 907 Terminology of Adhesives⁵

D 1200 Test Method for Viscosity by Ford Viscosity Cup⁴

D 1545 Test Method for Viscosity of Transparent Liquids by Bubble Time Method⁶

D 1601 Test Method for Dilute Solution Viscosity of Ethylene Polymers⁷

¹ These test methods are under the jurisdiction of ASTM Committee D-14 on Adhesives and are the direct responsibility of Subcommittee D14.10 on Working Properties.

Current edition approved March 10, 1997. Published May 1998. Originally published as D 1084 – 50. Last previous edition D 1084 – 88.

² *Annual Book of ASTM Standards*, Vol 04.04.

³ *Annual Book of ASTM Standards*, Vol 10.01.

⁴ *Annual Book of ASTM Standards*, Vol 06.01.

⁵ *Annual Book of ASTM Standards*, Vol 15.06.

⁶ *Annual Book of ASTM Standards*, Vol 06.03.

⁷ *Annual Book of ASTM Standards*, Vol 08.01.

D 2556 Test Method for Apparent Viscosity of Adhesives Having Shear-Rate-Dependent Flow Properties⁵

3. Terminology

3.1 *Definitions*—Many terms in these test methods are defined in Terminology D 907.

3.1.1 *viscosity, n—of a liquid*, the resistance to flow expressed as the ratio of the applied stress to the resulting rate of shearing strain (see Newtonian behavior, and thixotropy). (Compare consistency.)

3.2 *Definitions of Terms Specific to This Standard:*

3.2.1 *viscosity*—the ratio of shear stress to shear rate. The viscosity of a liquid is a measure of the internal friction of the liquid in motion. The unit of dynamic viscosity is the poise, which is expressed as dyne-seconds per square centimetre. For a Newtonian liquid, the viscosity is constant at all shear rates. For a non-Newtonian liquid, viscosity will vary depending on shear rate.

4. Significance and Use

4.1 Several test methods are noted for viscosity determination of Newtonian and near Newtonian flow characteristics. (For adhesives not fitting into this category, Test Method D 2556 should be considered.) Four test methods are covered as follows:

4.1.1 *Method A* is applicable only to adhesives that will deliver 50 mL in a steady uninterrupted stream from one of the cups described in Section 5.

4.1.2 *Method B* is intended for measuring the viscosity of adhesives covering a range from 0.05 Pa · s to 200 Pa · s (50 to 200 000 cP) and is limited to materials that have or approach Newtonian flow characteristics.

4.1.3 *Method C* is intended primarily as a control method for determining the viscosity of adhesives that have or approach Newtonian flow characteristics.

4.1.4 Method D is intended primarily as a control method for determining the viscosity of materials that have an equivalent viscosity no greater than approximately 3000 cP and is limited to materials that have or approach Newtonian flow characteristics.

TEST METHOD A

5. Apparatus

5.1 The apparatus (Fig. 1) consists of a set of four viscosity cups so designed as to deliver 50 mL of the sample in from 30 to 100 s at a temperature of $23 \pm 0.5^\circ\text{C}$ ($73.4 \pm 0.9^\circ\text{F}$).

5.1.1 Four consistency cups constitute a set as follows:

	Diameter of Orifice, in.
First Cup	0.07 ± 0.0001
Second cup	0.10 ± 0.0001
Third cup	0.15 ± 0.0001
Fourth cup	0.25 ± 0.0001

5.1.2 Cups made of brass or bronze. Orifice disks made of 18 % Chromium, 8 % Nickel stainless steel. The diameter of the Orifice pressed in the cup shall be stamped on the cup

5.1.3 Fractional dimensions subject to permissible variations of ± 0.01 in., unless otherwise specified.

6. Procedure

6.1 Bring the sample to be tested and the viscosity cup to a temperature of $23 \pm 0.5^\circ\text{C}$ ($73.4 \pm 0.9^\circ\text{F}$) (preferably in a constant-temperature room). Then mount the consistency cup in the clamp provided for the purpose and place the receiving cylinder in position. With the outlet of the cup closed by means

of the finger, pour the sample into the cup until it is filled to overflowing. Strike off the excess with a straightedge, and then remove the finger from over the outlet and allow the sample to flow into the receiving cylinder. Determine the number of seconds from the time the finger is removed from the orifice until the top of the meniscus reaches to 50-mL mark on the cylinder by a stop watch and record as the viscosity of the material.

7. Report

7.1 Report the following:

7.1.1 Complete identification of the adhesive tested, including type, source, manufacturer's code numbers, form, date of test, date of manufacture, etc.,

7.1.2 Conditioning procedure used for samples prior to testing,

7.1.3 Number of tests made, and

7.1.4 Average consistency in seconds and the number of the viscosity cup used.

TEST METHOD B

8. Apparatus

8.1 *Viscometer*—The apparatus consists of a Brookfield synchroelectric viscosimeter,⁸ or an equivalent instrument. A series of spindles with various sized disks is provided with

⁸ Manufactured by the Brookfield Engineering Laboratories, Stoughton, MA.

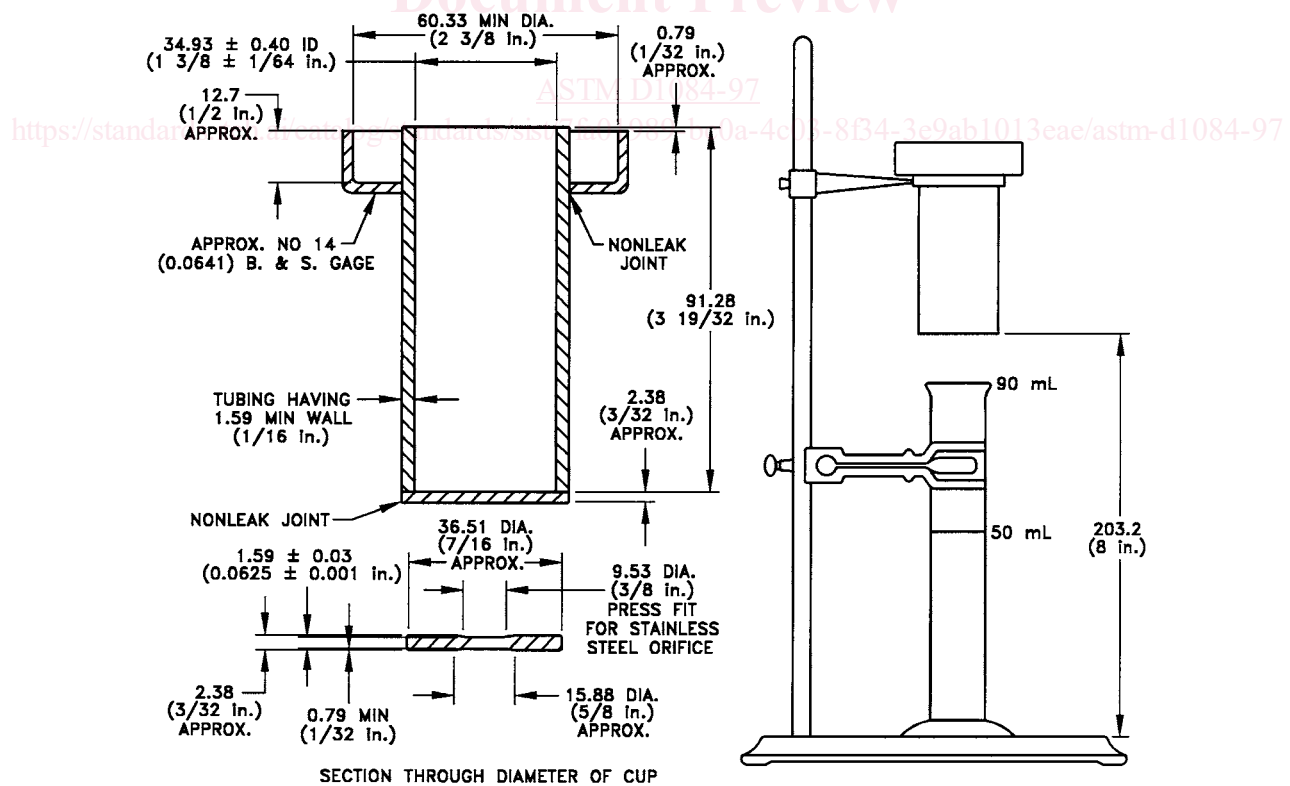

FIG. 1 Consistency Cups and Apparatus Assembly (Test Method A)