



SLOVENSKI STANDARD
SIST EN 12013:2000+A1:2008

01-november-2008

Stroji za predelavo gume in plastike - Notranji mešalniki - Varnostne zahteve

Plastics and rubber machines - Internal mixers - Safety requirements

Kunststoff- und Gummimaschinen - Innenmischer - Sicherheitsanforderungen

Machines pour les matières plastiques et le caoutchouc - Mélangeurs internes -
Prescriptions de sécurité

iTeh STANDARD PREVIEW

(standards.iTeh.ai)

[SIST EN 12013:2000+A1:2008](https://standards.iTeh.ai/catalog/standards/sist/6307c6d3-7001-4d77-a9a5-5bd4d688921/sist-en-12013-2000a1-2008)

Ta slovenski standard je istoveten z: EN 12013:2000+A1:2008

ICS:

83.200

Oprema za gumarsko
industrijo in industrijo
polimernih materialov

Equipment for the rubber and
plastics industries

SIST EN 12013:2000+A1:2008

en,fr

iTeh STANDARD PREVIEW
(standards.iteh.ai)

SIST EN 12013:2000+A1:2008

<https://standards.iteh.ai/catalog/standards/sist/6307c6d3-7001-4d77-a9a5-5bd4fd888921/sist-en-12013-2000a1-2008>

EUROPEAN STANDARD

EN 12013:2000+A1

NORME EUROPÉENNE

EUROPÄISCHE NORM

August 2008

ICS 83.200

Supersedes EN 12013:2000

English Version

Plastics and rubber machines - Internal mixers - Safety requirements

Machines pour les matières plastiques et le caoutchouc -
Mélangeurs internes - Prescriptions de sécurité

Kunststoff- und Gummimaschinen - Innenmischer -
Sicherheitsanforderungen

This European Standard was approved by CEN on 25 May 2000 and includes Amendment 1 approved by CEN on 8 June 2008.

CEN members are bound to comply with the CEN/CENELEC Internal Regulations which stipulate the conditions for giving this European Standard the status of a national standard without any alteration. Up-to-date lists and bibliographical references concerning such national standards may be obtained on application to the CEN Management Centre or to any CEN member.

This European Standard exists in three official versions (English, French, German). A version in any other language made by translation under the responsibility of a CEN member into its own language and notified to the CEN Management Centre has the same status as the official versions.

CEN members are the national standards bodies of Austria, Belgium, Bulgaria, Cyprus, Czech Republic, Denmark, Estonia, Finland, France, Germany, Greece, Hungary, Iceland, Ireland, Italy, Latvia, Lithuania, Luxembourg, Malta, Netherlands, Norway, Poland, Portugal, Romania, Slovakia, Slovenia, Spain, Sweden, Switzerland and United Kingdom.





iTeh STANDARD PREVIEW
(standards.iteh.ai)
<https://standards.iteh.ai/catalog/standards/sist/6307c6d3-7001-4d77-a9a5-5bd4fd888921/sist-en-12013-2000a1-2008>



EUROPEAN COMMITTEE FOR STANDARDIZATION
COMITÉ EUROPÉEN DE NORMALISATION
EUROPÄISCHES KOMITEE FÜR NORMUNG

Management Centre: rue de Stassart, 36 B-1050 Brussels

Contents

	Page
Foreword.....	3
Introduction	4
1 Scope	4
2 Normative references	4
3 Definitions	6
4 List of hazards.....	8
5 Safety requirements and/or measures	20
6 Verification of safety requirements and/or measures.....	31
7 Information for use	33
Annex A (informative) Examples of possible technical measures to prevent fire hazards in the case where certain exothermically reacting compounds cannot be released from the mixing chamber in the event of a power failure	36
Annex ZA (informative)  Relationship between this European Standard and the Essential Requirements of EU Directive 98/37/EC 	37
Annex ZB (informative)  Relationship between this European Standard and the Essential Requirements of EU Directive 2006/42/EC 	38

[SIST EN 12013:2000+A1:2008](https://standards.iteh.ai/catalog/standards/sist/6307c6d3-7001-4d77-a9a5-5bd4fd888921/sist-en-12013-2000a1-2008)

<https://standards.iteh.ai/catalog/standards/sist/6307c6d3-7001-4d77-a9a5-5bd4fd888921/sist-en-12013-2000a1-2008>

Foreword

This document (EN 12013:2000+A1:2008) has been prepared by Technical Committee CEN/TC 145 "Plastics and rubber machines", the secretariat of which is held by UNI.

This document shall be given the status of a national standard, either by publication of an identical text or by endorsement, at the latest by February 2009, and conflicting national standards shall be withdrawn at the latest by December 2009.

This document includes Amendment 1, approved by CEN on 2008-06-08. The main changes compared to the previous version are:

- Modification of the main element of the title.
- Editorial modification of Annex ZA.
- Addition of Annex ZB.
- Editorial changes of EN 292-1:1991 to EN ISO 12100-1:2003 and of EN 292-2:1991 to EN ISO 12100-2:2003 in the following clauses: Introduction, 2, 5, 5.1.8, 5.4, Table 1, 7.1.
- Minor changes in clause: Foreword, 7th paragraph and in sub-clauses: 7.1.4, third indent; 7.2, second and third indents.

This document supersedes EN 12013:2000.

The start and finish of text introduced or altered by amendment is indicated in the text by tags A1 and A1.

This European Standard has been prepared under a mandate given to CEN by the European Commission and the European Free Trade Association, and supports essential requirements of EU Directive(s).

A1 For relationship with EU Directive(s), see informative Annexes ZA and ZB, which are integral parts of this document. A1

According to the CEN/CENELEC Internal Regulations, the national standards organizations of the following countries are bound to implement this European Standard: Austria, Belgium, Bulgaria, Cyprus, Czech Republic, Denmark, Estonia, Finland, France, Germany, Greece, Hungary, Iceland, Ireland, Italy, Latvia, Lithuania, Luxembourg, Malta, Netherlands, Norway, Poland, Portugal, Romania, Slovakia, Slovenia, Spain, Sweden, Switzerland and United Kingdom.

EN 12013:2000+A1:2008 (E)**Introduction**

This European standard is a type C Standard as defined in **A1** EN ISO 12100 **A1** and has been elaborated by CEN/TC 145/WG7.

The extent to which hazards are covered is indicated in the scope of this standard. In addition, machinery shall comply as appropriate with **A1** EN ISO 12100 **A1** for hazards which are not covered by this standard.

1 Scope

This standard applies to internal mixers for rubber and plastics as defined in 3.1. The safety requirements and/or measures specified in this standard apply to all internal mixers irrespective of their size and irrespective of the control modes of the hopper front door and discharge door.

The safety requirements for the design of exhaust systems and ancillary equipment are not covered by this standard.

The safety requirements for the interaction between internal mixers and ancillary equipment are specified.

This standard covers the significant hazards listed in Clause 4.

This standard is not applicable to internal mixers which are manufactured before the date of publication of this standard by CEN.

STANDARD PREVIEW
(standards.iteh.ai)
<https://standards.iteh.ai/catalog/standards/sist/6307c6d3-7001-4d77-a9a5-5bd4fd888921/sist-en-12013-2000a1-2008>

2 Normative references

This European standard incorporates provisions from other publications by dated or undated references. These normative references are cited at the appropriate places in the text and the publications are listed below. For dated references, subsequent amendments or revisions of these publications apply to the European standard only when incorporated in it by amendment or revision. For undated references, the latest edition of the publication referred to applies (including amendments).

A1 *deleted text* **A1**

EN 294:1992, *Safety of Machinery- Safety distances to prevent danger zones being reached by the upper limbs*

EN 418:1992, *Safety of Machinery - Emergency stop equipment, functional aspects - Principles for design*

EN 563, *Safety of Machinery - Temperatures of touchable surfaces - Ergonomics data to establish temperature limit values for hot surfaces*

EN 574:1996, *Safety of Machinery - Two-hand control devices - Functional aspects - Principles for design*

EN 811, *Safety of Machinery - Safety distances to prevent danger zones being reached by the lower limbs*

EN 953:1997, *Safety of Machinery - Guards - General requirements for the design and construction of fixed and moveable guards*

EN 954-1:1996, *Safety of Machinery - Safety-related parts of control systems - Part 1: General principles for design*

- EN 982, *Safety of Machinery - Safety requirements for fluid power systems and their components - Hydraulics*
- EN 983, *Safety of Machinery - Safety requirements for fluid power systems and their components - Pneumatics*
- EN 999, *Safety of Machinery - The positioning of protective equipment in respect of approach speeds of parts of the human body*
- EN 1037, *Safety of Machinery - Prevention of unexpected start-up*
- EN 1088:1995, *Safety of Machinery - Interlocking devices associated with guards - Principles for design and selection*
- EN 1127-1, *Explosive atmospheres - Explosion prevention and protection - Part 1: Basic concepts and methodology*
- EN 60079-14, *Electrical apparatus for explosive gas atmospheres - Part 14: Electrical installations in hazardous areas (other than mines) (IEC 60079-14:1996)*
- EN 60204-1:1997, *Safety of Machinery - Electrical equipment of machines - Part 1: General requirements (IEC 60204-1:1997)*
- prEN 60204-11:1998, *Safety of machinery - Electrical equipment of machines - Part 11: General requirements for voltages above 1000 Va.c. or 1500 Vd.c and not exceeding 36 kV*
- EN 60529:1991, *Degrees of protection provided by enclosures (IP Code) (IEC 60529:1989)*
- EN 61310-1, *Safety of Machinery - Indication, marking and actuation - Part 1: Requirements for visual, auditory and tactile signals (IEC 61310-1:1995)*
- EN ISO 4871, *Acoustics - Declaration and verification of noise emission values of machinery and equipment (ISO 4871:1996)*
- EN ISO 11202, *Acoustics - Noise emitted by machinery and equipment – Measurement of emission sound pressure levels at a work station and at other specified positions - Survey method in situ (ISO 11202:1995)*
- EN ISO 11688-1, *Acoustics - Recommended practice for the design of low-noise machinery and equipment - Part 1: Planning (ISO/TR 11688-1:1995)*
- EN ISO 11688-2, *Acoustics - Recommended practice for the design of low-noise machinery and equipment - Part 2: Introduction to the physics of low-noise design (ISO/TR 11688-2:1998)* ^{A1}
- EN ISO 12100-1:2003, *Safety of machinery - Basic concepts, general principles for design - Part 1: Basic terminology, methodology (ISO 12100-1:2003)*
- EN ISO 12100-2:2003, *Safety of machinery - Basic concepts, general principles for design - Part 2: Technical principles (ISO 12100-2:2003)* ^{A1}
- EN ISO 14122-1, *Safety of machinery - Permanent means of access to machinery - Part 1: Choice of fixed means of access between two levels (ISO 14122-1:2001)*
- EN ISO 14122-2, *Safety of machinery - Permanent means of access to machinery - Part 2: Working platforms and walkways (ISO 14122-2:2001)*
- EN ISO 14122-3, *Safety of machinery - Permanent means of access to machinery - Part 3: Stairs, stepladders and guard-rails (ISO 14122-3:2001)*
- EN ISO 14122-4, *Safety of machinery - Permanent means of access to machinery - Part 4: Fixed ladders (ISO 14122-4:2004)* ^{A1}

EN 12013:2000+A1:2008 (E)

CENELEC Report R-044-001, *Safety of Machinery - Guidance and recommendations for the avoidance of hazards due to static electricity*

3 Definitions

For the purposes of this standard the following definitions apply:

3.1**internal mixer**

A mixing machine for the discontinuous production of rubber or plastic compounds. Its main parts are (Figure 1):

- two counter rotating horizontal rotors (a) within a mixing chamber (b);
- a feed hopper (c) with several openings:-
 - at the feed side, a feed opening equipped with a door (hopper front door) (d);
 - at the side opposite to the feed side, an inspection/access opening (hopper rear opening) equipped with a fixed or moveable guard (hopper rear door) (e);
 - possible additional feed openings for connection to feeding ducts (f);
- a floating weight which applies pressure to the materials to be mixed (g);
- a drop type or sliding type discharge door (h).

SIST EN 12013:2000+A1:2008
<https://standards.iteh.ai/catalog/standards/sist/6307c6d3-7001-4d77-a9a5-5bd4fd888921/sist-en-12013-2000a1-2008>

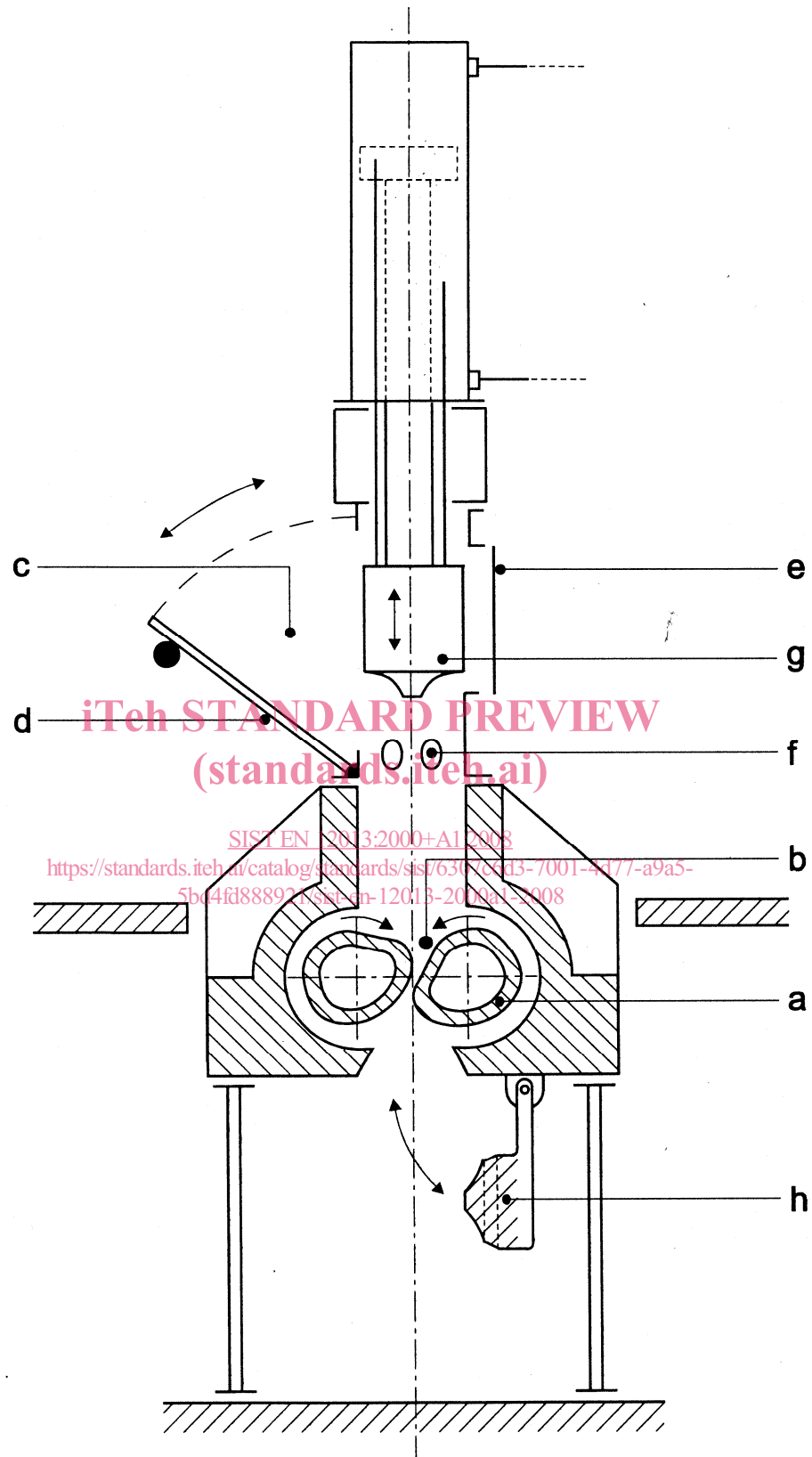

Figure 1 — Principal parts of an internal mixer

EN 12013:2000+A1:2008 (E)**3.2****ancillary equipment**

Equipment which interacts with the internal mixer. For the purposes of this standard this includes upstream and downstream equipment. Examples: belt conveyors, bin tippers, powder or liquid feeding systems, two-roll mills, extruders.

3.3**major cleaning**

a cleaning operation which requires suspension of production, the mixer to be emptied and access to the mixing chamber

4 List of hazards**4.1 Mechanical hazards**

The significant mechanical hazards which are specifically associated with internal mixers are described in 4.1.1 to 4.1.6; the significant mechanical hazards which are not specifically associated with internal mixers are described in 4.1.7 and 4.1.8. The mechanical hazards associated with major cleaning, maintenance and repair operations are included in 4.8.

4.1.1 Hazards in the loading area (Figure 2)

4.1.1.1 Hazards due to power operated movement of the hopper front door, automatically or manually controlled

a) Closing movement

Hazards of shearing and/or crushing between the door and the edges of the feed opening (location a). See also 4.1.3 c).

b) Opening movement

Hazards of crushing between the hopper front door and fixed parts, particularly its stops (location b).

4.1.1.2 Hazards through the feed opening

a) Hazards of severing, shearing and/or crushing due to movement of the floating weight

- between the floating weight and the fixed bridge member or upper edge of the feed opening on the upstroke of the floating weight (location c);
- between the floating weight and the lower edge of the feed opening on the downstroke of the floating weight (location d).

b) Hazards of severing, shearing and/or crushing between the rotors, or between the rotors and the walls of the mixing chamber (location e) in the case of:

- reaching through the opening;
- falling through the opening.

c) Hazards of injury to the eyes or skin in the case of splashing of process oil from the fluid injectors (location f).

4.1.1.3 Hazard of entanglement with strip-fed material (location g)

4.1.2 Hazards through the additional feed openings (Figure 2)

- a) Hazards of severing, shearing and/or crushing between the floating weight and the edges of these openings (location h);
- b) Hazards of severing, shearing and/or crushing between the rotors or between the rotors and the walls of the mixing chamber (location i);
- c) Hazards of injury to the eyes or skin in the case of splashing of process oil from the fluid injectors (location j).

iTeh STANDARD PREVIEW
(standards.iteh.ai)

[SIST EN 12013:2000+A1:2008](https://standards.iteh.ai/catalog/standards/sist/6307c6d3-7001-4d77-a9a5-5bd4fd888921/sist-en-12013-2000a1-2008)

<https://standards.iteh.ai/catalog/standards/sist/6307c6d3-7001-4d77-a9a5-5bd4fd888921/sist-en-12013-2000a1-2008>

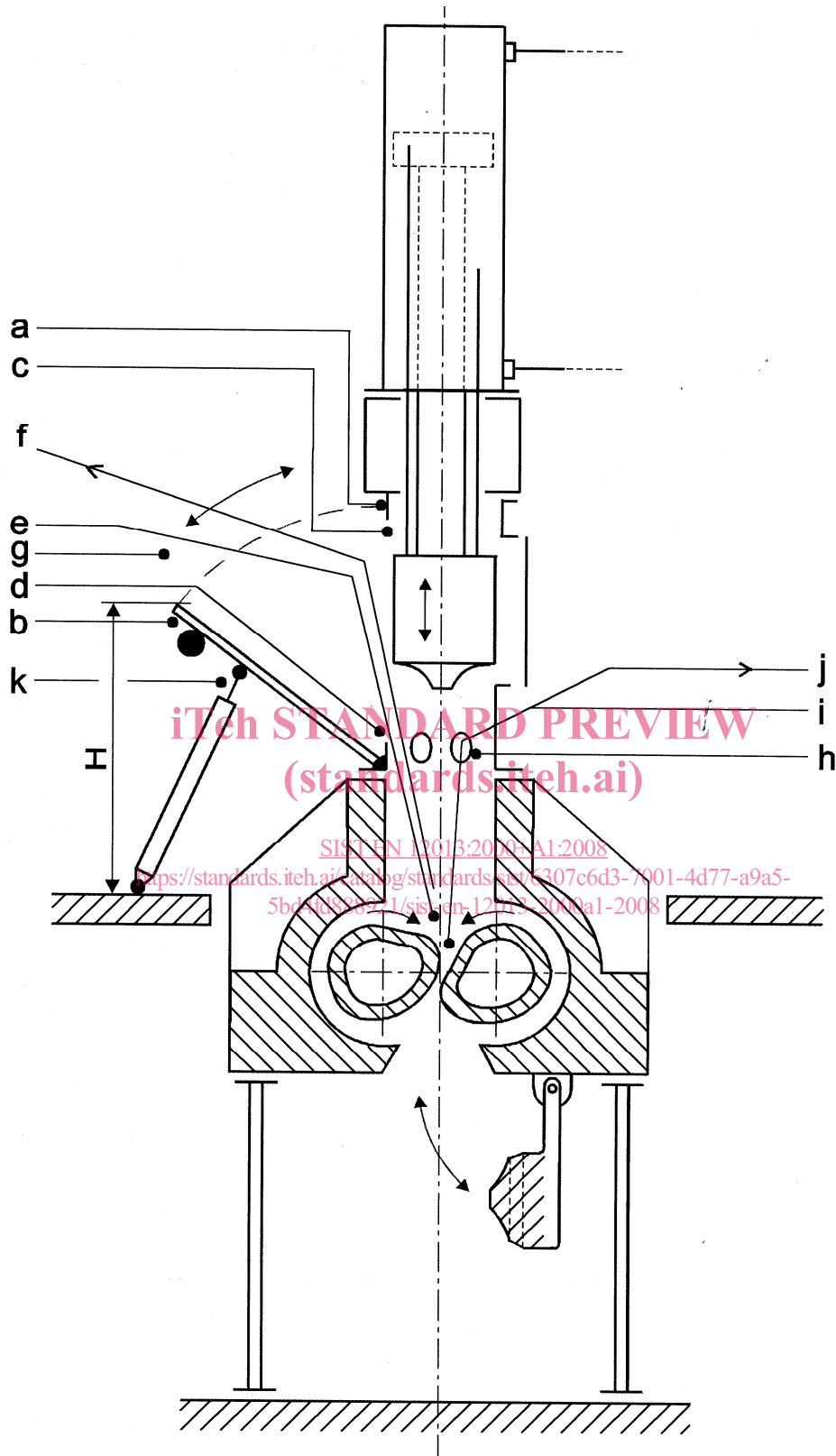

Figure 2 — Locations of the mechanical hazards in the loading area and at the additional feed openings

4.1.3 Hazards through the hopper rear opening (Figure 3)

- a) Hazards of severing, shearing and/or crushing due to movement of the floating weight
 - between the floating weight and the fixed bridge member or upper edge of the hopper rear opening on the upstroke of the floating weight (location a);
 - between the floating weight and the lower edge of the hopper rear opening on the downstroke of the floating weight (location b).
- b) Hazards of severing, shearing and/or crushing between the rotors or between the rotors and the walls of the mixing chamber (location c);
- c) Hazards of shearing and/or crushing between the power operated hopper front door and the edges of the feed opening when the hopper front door is closing (location d);
- d) Hazards of injury to the eyes or skin in the case of splashing of process oil from the fluid injectors (location e).

iTeh STANDARD PREVIEW (standards.iteh.ai)

[SIST EN 12013:2000+A1:2008](https://standards.iteh.ai/catalog/standards/sist/6307c6d3-7001-4d77-a9a5-5bd4fd888921/sist-en-12013-2000a1-2008)

<https://standards.iteh.ai/catalog/standards/sist/6307c6d3-7001-4d77-a9a5-5bd4fd888921/sist-en-12013-2000a1-2008>