

INTERNATIONAL STANDARD

**ISO
3378**

**IULTCS/IUP
12**

Second edition
2002-12-15

Leather — Physical and mechanical tests — Determination of resistance to grain cracking and grain crack index

*Cuir — Essais physiques et mécaniques — Détermination de la résistance
à la gerçure de la fleur et indice de gerçure*

iTeh STANDARD PREVIEW
(standards.iteh.ai)

[ISO 3378:2002](https://standards.iteh.ai/catalog/standards/sist/8ad94c2d-376b-4f8e-a436-d1d0124adfl7/iso-3378-2002)

[https://standards.iteh.ai/catalog/standards/sist/8ad94c2d-376b-4f8e-a436-
d1d0124adfl7/iso-3378-2002](https://standards.iteh.ai/catalog/standards/sist/8ad94c2d-376b-4f8e-a436-d1d0124adfl7/iso-3378-2002)



Reference number
ISO 3378:2002(E)
IULTCS/IUP 12

© ISO 2002

PDF disclaimer

This PDF file may contain embedded typefaces. In accordance with Adobe's licensing policy, this file may be printed or viewed but shall not be edited unless the typefaces which are embedded are licensed to and installed on the computer performing the editing. In downloading this file, parties accept therein the responsibility of not infringing Adobe's licensing policy. The ISO Central Secretariat accepts no liability in this area.

Adobe is a trademark of Adobe Systems Incorporated.

Details of the software products used to create this PDF file can be found in the General Info relative to the file; the PDF-creation parameters were optimized for printing. Every care has been taken to ensure that the file is suitable for use by ISO member bodies. In the unlikely event that a problem relating to it is found, please inform the Central Secretariat at the address given below.

iTeh STANDARD PREVIEW
(standards.iteh.ai)

[ISO 3378:2002](#)

<https://standards.iteh.ai/catalog/standards/sist/8ad94c2d-376b-4f8e-a436-d1d0124adfl7/iso-3378-2002>

© ISO 2002

All rights reserved. Unless otherwise specified, no part of this publication may be reproduced or utilized in any form or by any means, electronic or mechanical, including photocopying and microfilm, without permission in writing from either ISO at the address below or ISO's member body in the country of the requester.

ISO copyright office
Case postale 56 • CH-1211 Geneva 20
Tel. + 41 22 749 01 11
Fax + 41 22 749 09 47
E-mail copyright@iso.org
Web www.iso.org

Published in Switzerland

Contents

	Page
Foreword	iv
1 Scope	1
2 Normative references	1
3 Principle	1
4 Apparatus	1
5 Sampling and sample preparation	3
6 Procedure	3
7 Expression of results	3
8 Test report	4
Annex A (informative) The derivation of a grain crack index	5
Annex B (informative) Sources of apparatus	6

iTech STANDARD PREVIEW
(standards.itech.ai)

[ISO 3378:2002](https://standards.itech.ai/catalog/standards/sist/8ad94c2d-376b-4f8e-a436-d1d0124adfl7/iso-3378-2002)

<https://standards.itech.ai/catalog/standards/sist/8ad94c2d-376b-4f8e-a436-d1d0124adfl7/iso-3378-2002>

Foreword

ISO (the International Organization for Standardization) is a worldwide federation of national standards bodies (ISO member bodies). The work of preparing International Standards is normally carried out through ISO technical committees. Each member body interested in a subject for which a technical committee has been established has the right to be represented on that committee. International organizations, governmental and non-governmental, in liaison with ISO, also take part in the work. ISO collaborates closely with the International Electrotechnical Commission (IEC) on all matters of electrotechnical standardization.

International Standards are drafted in accordance with the rules given in the ISO/IEC Directives, Part 2.

The main task of technical committees is to prepare International Standards. Draft International Standards adopted by the technical committees are circulated to the member bodies for voting. Publication as an International Standard requires approval by at least 75 % of the member bodies casting a vote.

Attention is drawn to the possibility that some of the elements of this document may be the subject of patent rights. ISO shall not be held responsible for identifying any or all such patent rights.

ISO 3378 was prepared by the Physical Test Commission of the International Union of Leather Technologists and Chemists Societies (IUP Commission, IULTCS) in collaboration with the European Committee for Standardization (CEN) Technical Committee CEN/TC 289, *Leather*, the secretariat of which is held by UNI, in accordance with the Agreement on technical cooperation between ISO and CEN (Vienna Agreement). It is based on IUP 12 originally published in *J. Soc. Leather Trades Chemists* **44**, p. 380, (1960) and declared an official method of the IULTCS in 1961. This updated version was published in *J. Soc. Leather Tech. Chem.* **84**, p. 347, (2000) and reconfirmed as an official method in March 2001. This same principle is used but the text has been updated and includes the number of test pieces to be taken.

[ISO 3378:2002](https://standards.iteh.ai/catalog/standards/sist/8ad94c2d-376b-4f8e-a436-)

<https://standards.iteh.ai/catalog/standards/sist/8ad94c2d-376b-4f8e-a436->

This second edition cancels and replaces the first edition (ISO 3378:1975), which has been technically revised.

Leather — Physical and mechanical tests — Determination of resistance to grain cracking and grain crack index

1 Scope

This International Standard specifies a method for determining the resistance of leather to grain cracking and for determining the grain crack index. It is applicable to all heavy leathers.

2 Normative references

The following referenced documents are indispensable for the application of this document. For dated references, only the edition cited applies. For undated references, the latest edition of the referenced document (including any amendments) applies.

ISO 2418 *Leather - Chemical, physical and mechanical, and fastness tests - Sampling location*

ISO 2419 *Leather - Physical and mechanical tests - Sample preparation and conditioning*

ISO 2589 *Leather - Physical and mechanical tests - Determination of thickness*

3 Principle

A sample of leather is bent, grain outwards, around a mandrel of known diameter under the minimum force required to keep the leather and mandrel in contact. The grain is kept under observation and any cracking noted.

4 Apparatus

- <https://standards.iteh.ai/catalog/standards/sist/8ad94c2d-376b-4f8e-a436-d1d0124adfl7/iso-3378-2002>
- 4.1 Test machine**, including 4.2 to 4.4.
- 4.2 Clamp**, or other device, which rigidly holds one end of the test piece.
- 4.3 Cylindrical roller**, diameter 25,0 mm ± 0,5 mm fitted with a handle perpendicular to the axis with the position of the roller being adjustable with respect to its position on the handle.
- 4.4 Set of mandrels**, with diameters given in Table 1.

Table 1 — Diameter of mandrels

Mandrel number	Diameter mm
1	61,67 ± 0,03
2	35,00 ± 0,03
3	23,57 ± 0,03
4	17,22 ± 0,03
5	13,18 ± 0,03
6	10,38 ± 0,03
7	8,33 ± 0,03
8	6,76 ± 0,03

4.5 **The general arrangement**, is such that the roller (4.3) and mandrel (4.4) make contact with the grain and flesh surface respectively of the middle portion of the test piece across its full width. Ensure the axis of both the mandrel and the roller is perpendicular to the length of the test piece. Fix the axis of the mandrel relative to the clamp and fix the axle of the roller to a handle pivoted at the axis of the mandrel. Ensure the relative position of the clamp, roller and mandrel is adjustable so that the test piece is not subjected to any distortion when in contact with the mandrel and roller prior to the start of the test.

Figure 1 shows in plan view the relative position of the clamp (4.2), roller (4.3) and mandrel (4.4)

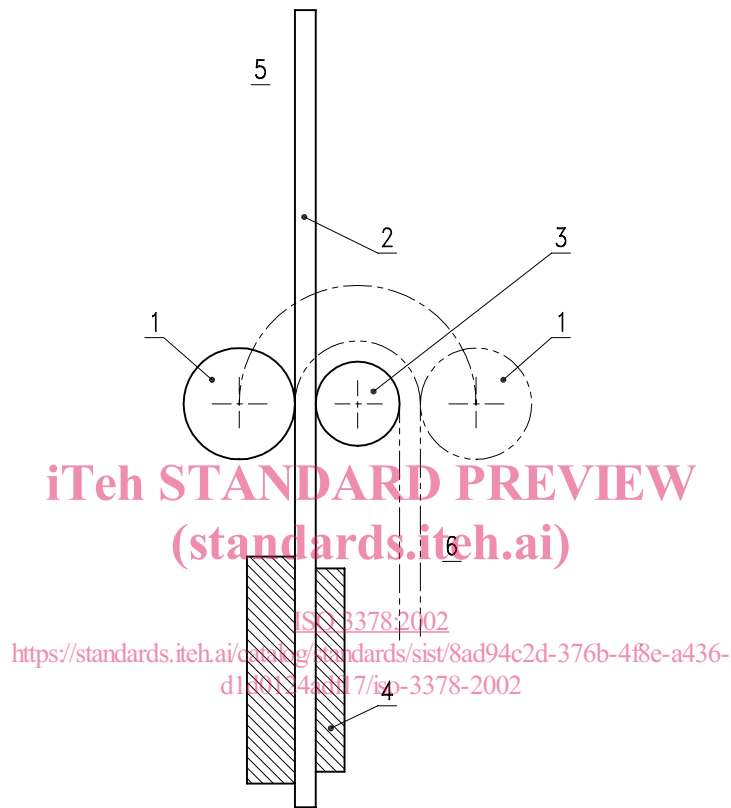

Key

- 1 Roller
- 2 Specimen
- 3 Mandrel
- 4 Clamp
- 5 Positions at beginning of test
- 6 Positions at end of test

Figure 1 — Positions of clamp, roller and mandrel

4.6 **Press knife**, the inner wall of which is a rectangle of width 25 mm ± 1 mm and minimum length 150 mm as specified in ISO 2419.

4.7 **Thickness gauge**, as specified in ISO 2589.

5 Sampling and sample preparation

5.1 Sample in accordance with ISO 2418. From the sample, cut six test pieces by applying the press knife (4.6) to the grain surface, three test pieces with the longer sides parallel to the backbone and three test pieces with the longer sides perpendicular to the backbone.

NOTE If there is a requirement for more than two hides or skins to be tested in one batch, then only one test piece in each direction need be taken from each hide or skin, provided that the overall total is not less than three test pieces in each direction.

5.2 Condition the test pieces in accordance with ISO 2419.

5.3 Determine the thickness of the test pieces in accordance with ISO 2589.

6 Procedure

6.1 Adjustment of the apparatus

6.1.1 Place the required mandrel in the machine.

6.1.2 Clamp one end of the test piece in position. Adjust the relative position of the clamp and mandrel so that the flesh side of the leather is in contact with the mandrel.

6.1.3 Attach the handle (4.3) to the axis of the mandrel and adjust the position of the roller until the roller touches the grain surface of the leather. Lock the axle of the roller in this position.

6.2 Resistance to grain cracking using a given mandrel

6.2.1 With the test piece and required mandrel in position (6.1), turn the handle through 180° in $5\text{ s} \pm 1\text{ s}$ thus bending the test piece grain outwards around the mandrel. During the bending observe the grain and note any cracking.

6.2.2 Repeat with other mandrels if required.

6.3 Determination of grain crack index

6.3.1 Using each of the numbered mandrels in turn, starting with no 1, carry out the procedure described in 6.1 and 6.2.1. Note the number of the largest mandrel which causes grain cracking.

7 Expression of results

7.1 If the resistance to cracking over a specified mandrel is determined, the result is expressed as a pass or failure.

7.2 If the grain crack index is determined, multiply the number, n , of the largest mandrel which causes cracking by the thickness, t , of the test piece, in millimetres, to obtain the grain crack index, $n \cdot t$. If the grain cracks when the leather is being bent round the largest mandrel (mandrel no 1), the grain crack index shall be expressed as "less than $1,5t$ " (not t). Similarly, if the grain fails to crack when bent round the smallest mandrel (mandrel no 8) the crack index shall be expressed as "greater than $8,5t$ " (not $8t$).

8 Test report

The test report shall contain the following for each test piece:

- a) reference to this International Standard, i.e. ISO 3378 : 2002;
- b) if the leather was tested over a specified mandrel (or mandrels) of specified diameter, the diameter of the mandrels and whether the samples passed or failed;
- c) the grain crack index, if determined;
- d) the standard atmosphere used for conditioning and testing as given in ISO 2419 (i.e., 20 °C/65 % relative humidity or 23 °C/50 % relative humidity);
- e) any deviations from the method specified in this International Standard;
- f) full details for identification of the sample and any deviation from ISO 2418 with respect to sampling.

iTeh STANDARD PREVIEW
(standards.iteh.ai)

[ISO 3378:2002](https://standards.iteh.ai/catalog/standards/sist/8ad94c2d-376b-4f8e-a436-d1d0124adfl7/iso-3378-2002)

<https://standards.iteh.ai/catalog/standards/sist/8ad94c2d-376b-4f8e-a436-d1d0124adfl7/iso-3378-2002>

Annex A (informative) The derivation of a grain crack index

A.1 The diameters of the set of mandrels are chosen so that bending a 5 mm thick leather round them causes extensions of the grain of $(5n + 2,5)\%$, if the neutral axis of the leather is assumed to be midway between the grain and flesh surface in the bent test piece.

If the leather does not crack on mandrel $(n - 1)$, but cracks on mandrel n , it cracks when its percentage extension lies between $5(n - 1) + 2,5$ and $5n + 2,5$ (that is, when the percentage extension lies between $5n - 2,5$ and $5n + 2,5$) so $5n$ is an acceptable estimate of the percentage extension of the grain at crack.

For a leather 5 mm thick, however, $5n$ is the grain crack index, so for this leather the grain crack index is equal to the estimated percentage extension of the grain when cracking occurs.

A.2 For leather of thickness other than 5 mm the grain crack index $n \cdot t$ is not exactly equal to the percentage extension of the grain at crack, but it is a sufficiently close estimate of it for those mandrel sizes on which cracking is likely to occur in practice. Table A.1 shows the grain crack index, **A**, and percentage extension of the grain at crack, **B**, for different leather thicknesses and mandrels on which the leather first cracks.

NOTE The percentage extension of the grain at crack is calculated on the assumption that this occurs midway between the extension given by the corresponding mandrel and that given by the next larger mandrel, and that the neutral axis is midway between the grain and flesh surface.

Table A.1 — Crack index and percentage extension of the grain at crack

Mandrel No.	Thickness of leather, millimetres											
	3		4		5		6		7		8	
	A	B	A	B	A	B	A	B	A	B	A	B
1	<4,5	-	<6	-	<7,5	-	<9	-	<10,5	-	<12	-
2	6	6	8	8	10	10	12	12	14	13	16	15
3	9	10	12	12	15	15	18	17	21	20	24	22
4	12	13	16	17	20	20	24	23	28	26	32	29
5	15	17	20	21	25	25	30	29	35	32	40	35
6	18	20	24	26	30	30	36	34	42	38	48	41
7	21	24	28	30	35	35	42	39	49	43	56	46
8	24	29	32	35	40	40	48	44	56	48	64	52
No crack at 8	>25,5		>34		>42,5		>51		>59,5		>68	

< represents "less than";
> represents "greater than"