

# INTERNATIONAL STANDARD

**ISO  
5404**

**IULTCS/IUP  
11**

First edition  
2002-12-15

---

---

## **Leather — Physical and mechanical tests — Determination of the water resistance of heavy leathers**

*Cuir — Essais physiques et mécaniques — Détermination de la résistance  
à l'eau des cuirs épais*

**iTeh STANDARD PREVIEW**  
**(standards.iteh.ai)**

[ISO 5404:2002](https://standards.iteh.ai/catalog/standards/sist/66692373-cdef-49a4-a0ee-682fe887afea/iso-5404-2002)

<https://standards.iteh.ai/catalog/standards/sist/66692373-cdef-49a4-a0ee-682fe887afea/iso-5404-2002>



Reference number  
ISO 5404:2002(E)  
IULTCS/IUP 11

© ISO 2002

**PDF disclaimer**

This PDF file may contain embedded typefaces. In accordance with Adobe's licensing policy, this file may be printed or viewed but shall not be edited unless the typefaces which are embedded are licensed to and installed on the computer performing the editing. In downloading this file, parties accept therein the responsibility of not infringing Adobe's licensing policy. The ISO Central Secretariat accepts no liability in this area.

Adobe is a trademark of Adobe Systems Incorporated.

Details of the software products used to create this PDF file can be found in the General Info relative to the file; the PDF-creation parameters were optimized for printing. Every care has been taken to ensure that the file is suitable for use by ISO member bodies. In the unlikely event that a problem relating to it is found, please inform the Central Secretariat at the address given below.

**iTeh STANDARD PREVIEW**  
**(standards.iteh.ai)**

[ISO 5404:2002](#)

<https://standards.iteh.ai/catalog/standards/sist/66692373-cdef-49a4-a0ee-682fe887afea/iso-5404-2002>

© ISO 2002

All rights reserved. Unless otherwise specified, no part of this publication may be reproduced or utilized in any form or by any means, electronic or mechanical, including photocopying and microfilm, without permission in writing from either ISO at the address below or ISO's member body in the country of the requester.

ISO copyright office  
Case postale 56 • CH-1211 Geneva 20  
Tel. + 41 22 749 01 11  
Fax + 41 22 749 09 47  
E-mail [copyright@iso.org](mailto:copyright@iso.org)  
Web [www.iso.org](http://www.iso.org)

Published in Switzerland

## Contents

	Page
Foreword.....	iv
1 Scope .....	1
2 Normative references .....	1
3 Terms and definitions.....	1
4 Principle .....	1
5 Apparatus .....	1
6 Sampling and sample preparation .....	3
7 Procedure .....	3
8 Expression of results .....	5
9 Test report .....	5
Annex A (informative).....	7

**ITeH STANDARD PREVIEW**  
(standards.iteh.ai)

[ISO 5404:2002](https://standards.iteh.ai/catalog/standards/sist/66692373-cdef-49a4-a0ee-682fe887afea/iso-5404-2002)

<https://standards.iteh.ai/catalog/standards/sist/66692373-cdef-49a4-a0ee-682fe887afea/iso-5404-2002>

## Foreword

ISO (the International Organization for Standardization) is a worldwide federation of national standards bodies (ISO member bodies). The work of preparing International Standards is normally carried out through ISO technical committees. Each member body interested in a subject for which a technical committee has been established has the right to be represented on that committee. International organizations, governmental and non-governmental, in liaison with ISO, also take part in the work. ISO collaborates closely with the International Electrotechnical Commission (IEC) on all matters of electrotechnical standardization.

International Standards are drafted in accordance with the rules given in the ISO/IEC Directives, Part 2.

The main task of technical committees is to prepare International Standards. Draft International Standards adopted by the technical committees are circulated to the member bodies for voting. Publication as an International Standard requires approval by at least 75 % of the member bodies casting a vote.

Attention is drawn to the possibility that some of the elements of this document may be the subject of patent rights. ISO shall not be held responsible for identifying any or all such patent rights.

ISO 5404 was prepared by the Physical Test Commission of the International Union of Leather Technologists and Chemists Societies (IUP Commission, IULTCS) in collaboration with the European Committee for Standardization (CEN) Technical Committee CEN/TC 289, *Leather*, the secretariat of which is held by UNI, in accordance with the Agreement on technical cooperation between ISO and CEN (Vienna Agreement). It is based on IUP 11 originally published in *J. Soc. Leather Trades Chemists* **44**, p. 495, (1960) and declared an official method of IULTCS in 1963. This updated version was published in *J. Soc. Leather Tech. Chem.* **84**, p. 339, (2000) and reconfirmed as an official method in March 2001. The same principle is used but the text has been updated and includes the number of test pieces to be taken.

[ISO 5404:2002](https://standards.iteh.ai/catalog/standards/sist/66692373-cdef-49a4-a0ee-682fe887afea/iso-5404-2002)

<https://standards.iteh.ai/catalog/standards/sist/66692373-cdef-49a4-a0ee-682fe887afea/iso-5404-2002>

# Leather — Physical and mechanical tests — Determination of the water resistance of heavy leathers

## 1 Scope

This International Standard specifies a method for determining the water resistance of heavy leathers. The method allows determination of the penetration time, water absorption, area of penetration and water penetration rate as required. It is applicable to all types of heavy leathers.

## 2 Normative references

The following referenced documents are indispensable for the application of this document. For dated references, only the edition cited applies. For undated references, the latest edition of the referenced document (including any amendments) applies.

ISO 2418 *Leather - Chemical, physical and mechanical and fastness tests - Sampling location*

ISO 2419 *Leather - Physical and mechanical tests - Sample preparation and conditioning*

ISO 2589 *Leather - Physical and mechanical tests - Determination of thickness*

## 3 Terms and definitions

For the purposes of this document, the following terms and definitions apply.

### 3.1

#### penetration time

duration of flexing in minutes which is just sufficient to cause water to cross from the wetted (grain) surface to the other face of the test piece

[ISO 5404:2002](https://standards.iteh.ai/catalog/standards/sist/66692373-cdef-49a4-a0ee-000000000000/iso-5404-2002)

[https://standards.iteh.ai/catalog/standards/sist/66692373-cdef-49a4-a0ee-](https://standards.iteh.ai/catalog/standards/sist/66692373-cdef-49a4-a0ee-000000000000/iso-5404-2002)

[000000000000/iso-5404-2002](https://standards.iteh.ai/catalog/standards/sist/66692373-cdef-49a4-a0ee-000000000000/iso-5404-2002)

### 3.2

#### water absorption

gain in mass of the test piece due to water content during any period of the test, expressed as a percentage of its conditioned mass prior to test

### 3.3

#### area of penetration

sum (in square millimetres) of the areas where water has crossed from the wetted (grain) surface to the other face of the test piece

### 3.4

#### penetration rate

water transmitted through the leather expressed in grams per square decimetre (of leather) per hour based on the mass of water transmitted in the 10 minute period at the start of the hour

## 4 Principle

The test piece is continuously wetted on one surface and is flexed and compressed in the same manner as the sole of a shoe during walking. This enables various aspects of heavy leather water resistance to be measured with respect to time.

## 5 Apparatus

**5.1 Test machine**, including the items described in 5.1.1 to 5.1.7. The general arrangement of the test machine is shown in Figure 1.

## ISO 5404:2002(E)

- 5.1.1 Roller (A)**, diameter 120 mm  $\pm$  2 mm and width 50 mm  $\pm$  1 mm.
- 5.1.2 Platform (C)**, with a roughened upper surface and with sufficient perforations to allow the surface to be kept wet by a flow of water through the platform.
- 5.1.3 Clamp (D)**, to hold one short side of the test piece (B) in a horizontal position on the platform (C).
- 5.1.4 Clamp (E)**, to attach the other short side of the test piece to the roller with the attached side being parallel to the axis of the roller. The clamp is held by a weak spring to maintain the sample under slight tension.
- 5.1.5 Water supply (F)**, through the platform (C) and a means of draining away excess water.
- 5.1.6 Means of moving the axis of the roller**, with a crank motion along the horizontal line XY with an amplitude of 100 mm  $\pm$  2 mm and a frequency of 20  $\pm$  1 cycles per minute about a point directly over the mid point of the test piece. The movement of the axis causes the roller to move backwards and forwards along the test piece, raising one end and bending it to conform to the shape of the roller.
- 5.1.7 Means of pressing the platform, test piece and roller together with a force of 80 N  $\pm$  5 N.**

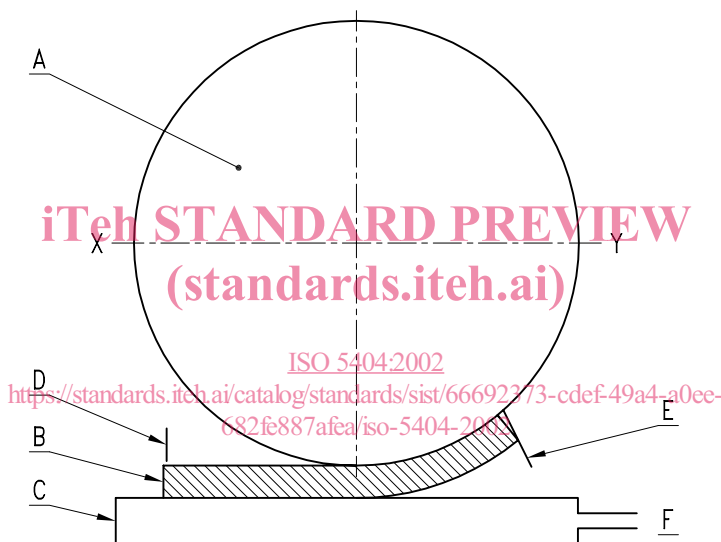

Figure 1 — General arrangement of test machine

- 5.2 Undyed cotton gauze**, cut into rectangles of 105 mm  $\pm$  5 mm  $\times$  45 mm  $\pm$  5 mm.
- 5.3 Press knife**, the inner wall of which is a rectangle 100 mm  $\pm$  1 mm  $\times$  40 mm  $\pm$  1 mm as specified in ISO 2419.
- 5.4 Thickness gauge**, as specified in ISO 2589.
- 5.5 Absorbent cellulosic board**, thickness 1,6 mm  $\pm$  0,1 mm and mass 1200 g/m<sup>2</sup>  $\pm$  300 g/m<sup>2</sup> cut into rectangles 105 mm  $\pm$  5 mm  $\times$  60 mm  $\pm$  5 mm.
- 5.6 Abrasive paper**, grade P120, as defined in the P-series grain size standard published by the Federation of European Producers of Abrasive Products.
- 5.7 Balance**, reading to 0,001 g.
- 5.8 Clock**, reading to 1 s.
- 5.9 Flexible waterproof adhesive**, for example polychloroprene, polyvinyl chloride or polyurethane.
- 5.10 Transparent overlay**, minimum size 100 mm  $\times$  40 mm, marked with a central matrix of 28  $\times$  10 squares of area 9 mm<sup>2</sup> as shown in Figure 2.

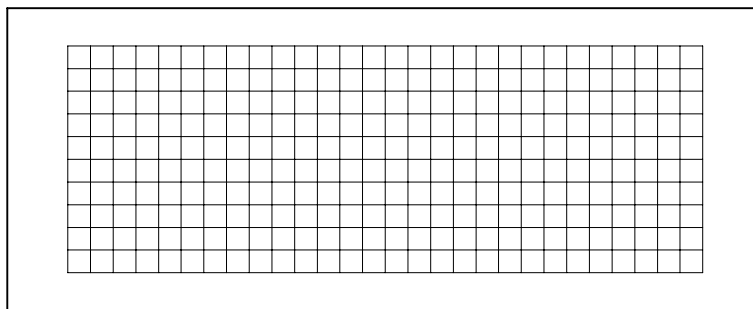

Figure 2 —Transparent overlay

## 6 Sampling and sample preparation

**6.1** Sample in accordance with ISO 2418. From the sample, cut two test pieces by applying the press knife (5.3) to the grain surface with the longer side parallel to the backbone.

NOTE If there is a requirement for more than two hides or skins to be tested in one batch, then only one test piece need be taken from each hide or skin, provided that the overall total is not less than two test pieces.

**6.2** Place the surface which is to be in contact with the ground (normally the grain surface), on a fresh piece of abrasive paper (5.6). Press the test piece against the abrasive paper with a force of  $10 \text{ N} \pm 1 \text{ N}$ . Roughen the leather surface by moving the test piece 10 times backwards and forwards over the abrasive paper for  $100 \text{ mm} \pm 10 \text{ mm}$  each time.

NOTE A thin waterproof finish applied to the grain of sole leather may greatly reduce penetration of water into it during the test, but be ineffective on a sole because it is rapidly removed during wear. For this reason, the test pieces are roughened as described above prior to testing. The aim of this preparation is to remove the finish. If a heavier finish has been applied then more abrasion may be required.

**6.3** Apply a coat of flexible adhesive (5.9) to the cut edges of the test piece, ensuring that there are no air bubbles within the coat. Allow to dry for  $35 \text{ min} \pm 5 \text{ min}$  and apply a second coat of adhesive.

**6.4** Condition the test piece in accordance with ISO 2419.

**6.5** If the water penetration rate is to be determined, condition the cellulosic board (5.5) in accordance with ISO 2419.

## 7 Procedure

### 7.1 General

**7.1.1** Weigh the test piece,  $M_0$ , to the nearest 0,001 g.

**7.1.2** Determine the thickness in accordance with ISO 2589.

**7.1.3** Place the cotton gauze (5.2) on the platform and adjust the flow of water to give a flow of  $7,5 \text{ ml/min} \pm 2,5 \text{ ml/min}$  over the platform.

**7.1.4** Lay the test piece on the gauze with the roughened surface downwards and attach the narrow ends to the platform and roller.

**7.1.5** Set the roller in motion and record the time.

## 7.2 Determination of penetration time

Record the time at which water is clearly seen on the leather surface adjacent to the roller, ignoring any penetration in an area 5 mm from the edge of the test piece.

NOTE An acoustic or optical signal may be used to assist in the detection of initial water penetration.

## 7.3 Determination of water absorption

**7.3.1** At the end of the first hour of test (or at such other times as may be specified), stop the machine, remove the test piece and blot it lightly with filter paper to remove water adhering to the surface, taking care not to force water out of the sample. Weigh the test piece,  $M_1$ .

**7.3.2** Return the test piece to the machine and continue the test.

**7.3.3** Repeat the procedure at the end of each hour until the test is completed (see NOTE 1 and NOTE 2 in 7.5.3).

## 7.4 Determination of area of penetration

**7.4.1** At the end of the first hour stop the machine and remove the test piece. Lay the transparent overlay over the upper surface of the test piece and estimate the total area of penetration by comparing the wetted areas, if any, with the areas marked on the overlay. If visual examination shows that wetting of the upper surface is taking place from the edge then the test is to be regarded as invalid and repeated with a fresh test piece.

**7.4.2** Return the test piece to the machine and continue the test.

**7.4.3** Repeat the procedure at the end of each hour until the test is completed.

NOTE 1 The area of penetration may be determined when the test piece is removed for determination of water absorption.

NOTE 2 See NOTE 1 and NOTE 2 in 7.5.3.

## 7.5 Determination of water penetration rate

**7.5.1** Weigh a rectangle of cellulosic board (5.5),  $W_0$ , to the nearest 0,001 g.

**7.5.2** At the end of the hour during which penetration first occurs, stop the machine and wipe the roller to remove any water adhering to it. Place a weighed rectangle of cellulosic board between the test specimen and roller and restart the machine. After a further 10 min  $\pm$  0,2 min stop the machine, remove the board and reweigh,  $W_1$ . If the cellulosic board has no dry parts, the results are to be rejected and the test repeated with a fresh test piece and absorbent board with the test period being reduced and a corresponding correction being made to the calculation for water penetration rate.

**7.5.3** Repeat the procedure at the end of each further hour until the test is completed.

NOTE 1 The period when the machine is stopped for weighing the test piece, the measurement of area of penetration or for inserting or removing absorbent boards should be as short as possible and the fact that the machine was stopped during these periods is ignored in the measurement of the intervals.

NOTE 2 It is generally convenient to measure water absorption, water penetration rates and area of penetration at intervals of 1 h (e.g. after 1 h, 2 h, 3 h.... of flexing) but for some leathers shorter intervals may be more appropriate. A total time of 2 h is normally sufficient for routine testing.



## 8 Expression of results

### 8.1 Water absorption

The water absorption  $W_a$ , expressed as a percentage (%), shall be calculated using the formula:

$$W_a = \frac{(M_1 - M_0) \times 100}{M_0}$$

where:

$M_1$  is the mass of test piece after any test period, in grams

$M_0$  is the initial conditioned mass of the test piece, in grams

### 8.2 Water penetration rate

The water penetration rate  $W_p$ , in grams per square centimetre hour ( $\text{g}/\text{cm}^2 \cdot \text{h}$ ), shall be calculated using the formula:

$$W_p = 0,15(W_1 - W_0)$$

where:

$W_1$  is the mass of the absorbent board, in grams, after any 10 minute test period

$W_0$  is the initial conditioned mass of the absorbent board, in grams

The constant (0,15) converts the test period (10 min) and the test piece area ( $40 \text{ cm}^2$ ) into grams per square centimetre per hour as follows:

$$0,15 = \frac{1}{40} \times \frac{60}{10}$$

## 9 Test report

The test report shall include the following for each test piece:

- a) reference to this International Standard, i.e. ISO 5404:2002;
- b) the thickness of the test piece in mm;
- c) the penetration time in h and min, if determined;