



Designation: D 5635 – 03

Standard Test Method for Dynamic Puncture Resistance of Roofing Membrane Specimens¹

This standard is issued under the fixed designation D 5635; the number immediately following the designation indicates the year of original adoption or, in the case of revision, the year of last revision. A number in parentheses indicates the year of last reapproval. A superscript epsilon (ϵ) indicates an editorial change since the last revision or reapproval.

1. Scope

1.1 This test method covers the evaluation of the maximum dynamic puncture load that roofing membrane samples can withstand, without allowing the passage of water, when subjected to impact from a rigid object having a sharp edge.

1.2 This laboratory test can be conducted at any desired temperature using membrane samples manufactured in a factory or prepared in a laboratory.

1.3 Roof membrane specimens to which the test method is applicable include bituminous built-up, polymer-modified bitumens, vulcanized rubbers, non-vulcanized polymeric, and thermoplastic materials.

1.4 This test method is not applicable to aggregate-surfaced membrane specimens; however, it is applicable to specimens having factory-applied granules.

1.5 The values stated in SI units are to be regarded as the standard. The values given in parentheses are for information only.

1.6 *This standard does not purport to address all of the safety concerns, if any, associated with its use. It is the responsibility of the user of this standard to establish appropriate safety and health practices and determine the applicability of regulatory limitations prior to use.*

2. Referenced Documents

2.1 ASTM Standards:

C 578 Specification for Rigid, Cellular Polystyrene Thermal Insulation²

D 1079 Terminology Relating to Roofing, Waterproofing, and Bituminous Materials³

3. Terminology

3.1 Definitions:

¹ This test method is under the jurisdiction of ASTM Committee D08 on Roofing and Waterproofing and is the direct responsibility of Subcommittee D08.20 on Roofing Membrane Systems.

Current edition approved Oct. 1, 2003. Published November 2003. Originally approved in 1994. Last previous edition approved in 1998 as D 5635 – 98.

² *Annual Book of ASTM Standards*, Vol 04.06.

³ *Annual Book of ASTM Standards*, Vol 04.04.

3.1.1 For definitions of terms used in this test method, refer to Terminology D 1079.

4. Summary of Test Method

4.1 The roofing membrane test specimen, set on a thermal insulation substrate, is subjected to a predetermined dynamic impact load created by a rigid falling puncture head. The head falls through a quarter-circle trajectory from a vertical position to horizontal position under gravitational acceleration.

4.2 The puncture energy is increased from 5 to 50 J (119 to 1190 ft-pdl) in 2.5 J (59.4 ft-pdl) increments until puncture of the membrane specimen occurs or until the maximum energy is reached.

4.3 Puncture of the test specimen is assessed by visual examination and verified by conducting a watertightness test.

5. Principle of the Test Method

5.1 The energy at impact is equated to the potential energy of the raised puncture head as follows:

$$E = mgH \quad (1)$$

where:

m = mass of the puncture head (in kg or lbm),

g = gravitational acceleration (in m/s^2 or ft/s^2), and

H = height through which the puncture head falls (in metres or feet).

In this test method, the height is fixed at 0.51 m (1.67 ft). With gravitational acceleration being equal to $9.8 m/s^2$ ($32 ft/s^2$), the impact energy is, thus, equal to the following:

$$E = 5 \cdot m \quad (2)$$

where:

m = kg.

or

$$E = 53.4 \cdot m \quad (3)$$

where:

m = lbm.

Increasing the mass of the puncture head from 1 to 10 kg (2.2 to 22 lbm) in increments of 0.5 kg (1.1 lbm) increases the

puncture energy from 5 to 50 J (119 to 1190 ft-pdl) in increments of 2.5 J (59.4 ft-pdl).

NOTE 1—A counter weight placed on the falling arm opposite to the axis of rotation eliminates the need to include the mass of the arm in the determination of the impact energy.

6. Significance and Use

6.1 An important factor affecting the performance of membrane roofing systems is their ability to resist dynamic puncture loads. This test method provides a means to assess dynamic puncture resistance.

6.2 This test method can be used to compare the dynamic puncture resistance of a single type of membrane as a function of a variety of insulation substrates or, conversely, to compare the resistance of a number of membrane specimens set on a single type of insulation.

6.3 The effect of temperature on puncture resistance can be studied by conducting the test under controlled conditions using such equipment as an environmental chamber, oven, or freezer.

6.4 The test method can be useful in developing performance criteria for membrane roofing systems.

6.5 The test method can be useful in developing classifications of dynamic puncture resistance of membrane roofing systems.

6.6 While it is considered that the results obtained by this laboratory test can afford a measure of the dynamic puncture resistance of membrane roofing systems in the field, (provided that service loads and temperature conditions are known) no direct correlation has yet been established.

7. Apparatus

7.1 *Dynamic Puncture Device*—The dynamic puncture device consists primarily of a heavy base, a falling arm, and puncture head (see Fig. 1).

7.1.1 The falling arm is attached to the base so that it can rotate freely (for example, using ball bearings) from a vertical to horizontal position. The length of the arm is sufficiently long

so that the puncture head can be secured to it at a distance that is 0.51 m (1.67 ft), $\pm 0.5\%$, from the point of rotation at the base.

7.1.2 The shape and dimensions of a typical puncture head are given in Fig. 2. When mounted on the arm, the face of the puncture head is parallel to axis of rotation. Several heads of different mass may be needed. Alternatively, a means for adding weights to a given puncture head to increase its mass can be used. The head and additional weights shall constitute a continuous series of mass from 1 to 10 kg (2.2 to 22 lbm) in 0.5 kg (1.1 lbm) increments. The mass of the puncture head shall be within $\pm 0.5\%$ of that selected.

NOTE 2—It is suggested that the puncture head be fabricated from 1018 mild steel to minimize risk of damage during its use. No matter the metal from which the puncture head is made, users of the test device should periodically examine the puncture head to check that damage has not occurred during use.

7.1.3 A counter weight, equivalent to the mass of the falling arm, is placed on the arm on the side of the axis of rotation opposite to that holding the puncture head. The presence of the counter weight eliminates the need to include the mass of the arm in the determination of the puncture energy. Alternatively, if a counter weight is not used, then the mass of the arm shall be included in the determination of the impact energy.

7.1.4 The device shall incorporate a mechanism that allows the puncture head to be kept stationary in an upright position, forming an angle from the vertical not exceeding 5° . This mechanism shall allow release of the arm so that it falls freely without any additional motion imposed.

NOTE 3—A vacuum release mechanism has been found suitable for this purpose.

7.1.5 The base of the device, supporting the arm and puncture head, is placed on a horizontal surface that is sufficiently stable. This surface will not shake, vibrate, or otherwise move when the test is conducted at maximum impact energy. The arm of the dynamic puncture device shall be horizontal when the puncture head contacts the horizontal surface of the test specimen (see Fig. 1). Heavy rigid shims having length and width dimensions larger than those of the test specimen and substrate may be used.

7.2 *Specimen Frame*—A frame, having minimum exterior and interior dimensions of 250 by 250 mm (9.8 by 9.8 in.) and 200 by 200 mm (7.9 by 7.9 in.), respectively, and a minimum mass of 2.5 kg (5.5 lbm) is used to hold the test specimen in place on the insulation substrate during the test. Adhere medium abrasive, 60 grit sand paper to the bottom surface of the specimen frame.

NOTE 4—The bottom surface of the frame is that surface which sets on the specimen. The use of sand paper assists in securing the specimen during test. Double-side adhesive tape has been found suitable for adhering the sand paper to metal frames. The sand paper is replaced with new pieces when it no longer assists in securing the specimen during test.

8. Sampling and Sample Preparation

8.1 *Single-Ply Samples*—Cut the test specimens directly from the sheet membrane material in accordance with 9.1.

8.2 *Multi-Ply Samples Prepared in the Laboratory*:

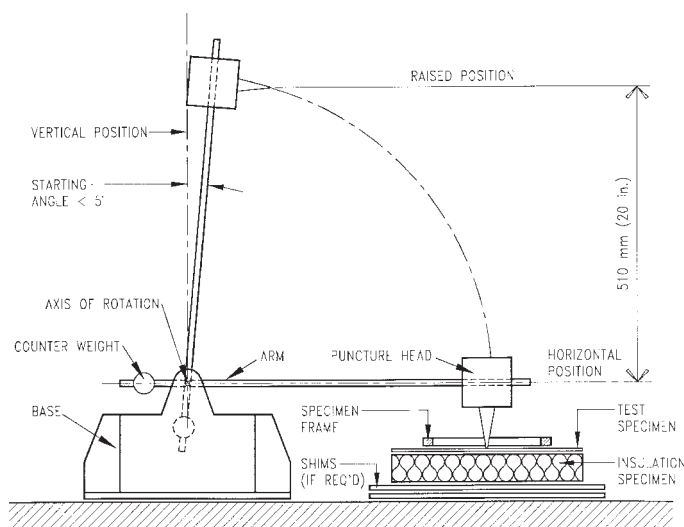

FIG. 1 Schematic of the Dynamic Puncture Device