



# Standard Guide for Construction of Solid Fuel Burning Masonry Heaters<sup>1</sup>

This standard is issued under the fixed designation E 1602; the number immediately following the designation indicates the year of original adoption or, in the case of revision, the year of last revision. A number in parentheses indicates the year of last reapproval. A superscript epsilon ( $\epsilon$ ) indicates an editorial change since the last revision or reapproval.

## 1. Scope

1.1 This guide covers the design and construction of solid fuel burning masonry heaters. It provides dimensions for site constructed masonry heater components and clearances that have been derived by experience and found to be consistent with the safe installation of those masonry heaters.

1.2 Values given in SI units are to be regarded as standard. Inch/pound units may be rounded (see IEEE/ASTM SI-10). All dimensions are nominal unless specifically stated otherwise. All clearances listed in this guide are actual dimensions.

1.3 This guide applies to the design and construction of masonry heaters built on-site with the components and materials specified herein. It does not apply to the construction/installation requirements for component systems that have been safety tested and listed. The requirements for listed masonry heater systems are specified in the manufacturer's installation instructions.

1.4 The design and construction of solid fuel burning masonry heaters shall comply with applicable building codes.

## 2. Referenced Documents

### 2.1 ASTM Standards:<sup>2</sup>

C 11 Terminology Relating to Gypsum and Related Building Materials and Systems

C 43 Terminology of Structural Clay Products

C 71 Terminology Relating to Refractories

C 270 Specification for Mortar for Unit Masonry

C 401 Classification of Alumina and Alumina-Silicate Castable Refractories

E 136 Test Method for Behavior of Materials in a Vertical Tube Furnace at 750°C

IEEE/ASTM SI-10 Standard for Use of the International System of Units (SI): The Modern Metric System

### 2.2 UL Standards:

UL 103 Chimneys, Factory Built Residential Type and Building Heating Appliances<sup>3</sup>

## 3. Terminology

3.1 Terms used in this guide are as defined in Terminology C 11, Definitions C 43, Terminology C 71, and Classification C 401.

### 3.2 Definitions of Terms Specific to This Standard:

3.2.1 *approved*—acceptable to the authority having jurisdiction.

3.2.2 *authority having jurisdiction*—the organization, office, individual, or agent thereof, who is responsible for approving construction, materials, equipment, installation, procedure, etc. and so forth. In most cases in which a building permit is required, the authority is typically the building official or his agent. Where a building permit is not required, the authority is typically the owner or his agent.

3.2.3 *bypass damper*—a valve or plate that provides a direct path to the chimney flue for the flue gases or portion thereof.

3.2.4 *capping slab*—a horizontal refractory barrier covering the top of the masonry heater.

3.2.5 *cleanout opening*—an access opening in a flue passageway of the masonry heater or chimney that is designed to allow access to the flue for purposes of inspecting for and removal of ash, soot, and other extraneous matter that may become trapped.

3.2.6 *damper*—an adjustable valve or plate for controlling draft or the flow of gases, including air.

3.2.7 *firebox (firechamber)*—that portion of the masonry heater that is designed for containing and burning the fuel charge.

<sup>1</sup> This guide is under the jurisdiction of ASTM Committee E06 on Performance of Buildings and is the direct responsibility of Subcommittee E06.54 on Solid Fuel Burning Applications.

Current edition approved Jan. 10, 2001. Published April 2001. Originally published as E1602-94. Last previous edition E1602-94.

Current edition approved Oct. 1, 2003. Published November 2003. Originally published as E 1602 - 94. Last previous edition E 1602 - 94.

<sup>2</sup> Annual Book of ASTM Standards, Vol 04.01.

<sup>2</sup> For referenced ASTM standards, visit the ASTM website, [www.astm.org](http://www.astm.org), or contact ASTM Customer Service at [service@astm.org](mailto:service@astm.org). For Annual Book of ASTM Standards volume information, refer to the standard's Document Summary page on the ASTM website.

<sup>3</sup> Annual Book of ASTM Standards, Vol 04.05.

<sup>3</sup> Available from Underwriter's Laboratories, 333 Pfingsten Road, Northbrook, IL 60062.

3.2.8 *gas slot*—a small fixed opening that provides a bypass for unburned flue gases, and is a critical safety feature in certain masonry heater designs (namely those of the Grundofen type with vertical flue runs) (see Figs. 1 and Fig. 1, Fig. 2, Fig. 32, and Fig. 6).

3.2.9 *hearth extension*—the noncombustible surfacing applied to the floor area extending in front of and beyond each side of the fuel loading door of the masonry heater; also applies to the floor beneath a masonry heater or beneath an elevated overhanging masonry heater hearth.

3.2.10 *masonry heater base*—that portion of the support for the masonry heater, between the masonry heater and the foundation, that is below the firebox or the heat exchange areas.

3.2.11 *heat-exchange flue channel*—a chamber or passageway between the firebox and the chimney flue in which heat resulting directly from combustion of fuel is transferred to the surrounding masonry.

3.2.12 *kachel*—a European term used to describe a masonry heater tile; a refractory ceramic tile intended for the outer wall of a masonry heater that is designed specifically to store and transfer heat.

3.2.13 *listed*—equipment or materials included in a list published by an organization concerned with product evaluation acceptable to the authority having jurisdiction to conduct periodic inspection of production of listed equipment or materials and whole listing states either that the equipment or materials meet appropriate standards or have been tested and found suitable for use in a specified manner.

3.2.14 *masonry heater*—a vented heating system of predominantly masonry construction having a mass of at least 800 kg (1760 lbs), excluding the chimney and masonry heater base. In particular, a masonry heater is designed specifically to capture and store a substantial portion of the heat energy from a solid fuel fire in the mass of the masonry heater through internal heat exchange flue channels, enable a charge of solid fuel mixed with an adequate amount of air to burn rapidly and more completely at high temperatures in order to reduce emission of unburned hydrocarbons, and be constructed of sufficient mass and surface area such that under normal operating conditions, the external surface temperature of the masonry heater (except in the region immediately surrounding the fuel loading door(s)), does not exceed 110°C (230°F).

3.2.15 *mortar, masonry*—a mixture of cementitious materials (consisting of Portland or blended cement and hydrated lime, masonry cement, masonry cement and Portland cement, or masonry cement and blended cement), fine aggregate, and sufficient water to produce a workable consistency (see Specification C 270).

3.2.16 *mortar, fire clay*—mortar consisting of fine aggregate and fire clay as a binding agent.

3.2.17 *mortar, soapstone refractory*—a mixture of powdered soapstone and sodium silicate.

3.2.18 *noncombustible material*—a material that, in the form in which it is used and under the conditions anticipated, does not ignite, burn, support combustion, or release flammable vapors when subjected to fire or heat. Materials reported as passing the requirements of Test Method E 136 are, for the purpose of this guide, considered noncombustible.

3.2.19 *soapstone*—a variety of natural stone (hydrated silica of magnesium) that is suitable for high-temperature applications in masonry heaters.

3.2.20 *wing wall*—a noncombustible lateral projection from the exterior wall of a masonry heater for use in bridging the space between a masonry heater and a combustible partition wall.

## 4. Significance and Use

4.1 This guide can be used by code officials, architects, and other interested parties to evaluate the design and construction of masonry heaters. It is not restricted to a specific method of construction, nor does it provide all specific details of construction of a masonry heater. This guide does provide the principles to be followed for the safe construction of masonry heaters.

4.2 This guide is not intended as a complete set of directions for construction of masonry heaters.

4.3 Construction of masonry heaters is complex, and in order to ensure their safety and performance, construction shall be done by or under the supervision of a skilled and experienced masonry heater builder.<sup>4</sup>

## 5. Requirements

5.1 *Foundation*—Masonry heater foundations and foundation walls shall meet local building codes for standard masonry fireplaces and shall be designed with consideration given to the mass and size of the masonry heater.

5.2 *Clearance from Combustibles*—Clearances shall be in conformance with this section, as illustrated in Fig. 3–Fig. 4.

5.2.1 *Clearance from Foundation*—All combustible structural framing members shall have a clearance of not less than 50 mm (2 in.) from the masonry heater foundation.

5.2.2 *Clearance from Fuel-Loading Door*—Maintain a minimum clearance of 1200 mm (48 in.) from combustible materials to fuel-loading doors, unless an engineered protection system as specified in 5.2.2.1 is provided, except for clearance directly in front of fuel-loading doors. A minimum clearance of 1200 mm (48 in.) shall be maintained in front of fuel-loading doors. This dimension shall not be reduced for any reason.

<sup>4</sup>Annual Book of ASTM Standards, Vol 15.01.

<sup>4</sup>The Masonry Heater Association of North America, 1252 Stock Farm Road, Randolph, VT 05060, web site: <http://www.mha-net.org>, is one organization that represents a body of knowledge on masonry heater construction and qualified builders.

The Masonry Products Caucus of the Hearth Products Association, 1601 N. Kent Street, Suite 1001, Arlington, VA 22209, web site: <http://www.hearthassoc.org>, is another organization that represents both manufacturers and qualified builders of masonry heaters.

FIG. 1 Vertical Channel  
Masonry Heater  
(Russian)

1. Ashbox
2. Ash Drop
3. Capping Slab
4. Chimney
5. Clean-Out
6. Combustion Air
7. Downdraft Channel
8. Exhaust Gas
9. Expansion Joint
10. Exterior Wall
11. Firebox
12. Fuel-Loading Door
13. Gas Slot
14. Hearth Extension
15. Heater Base
16. Insulation
17. Shut-Off Damper
18. Updraft Channel

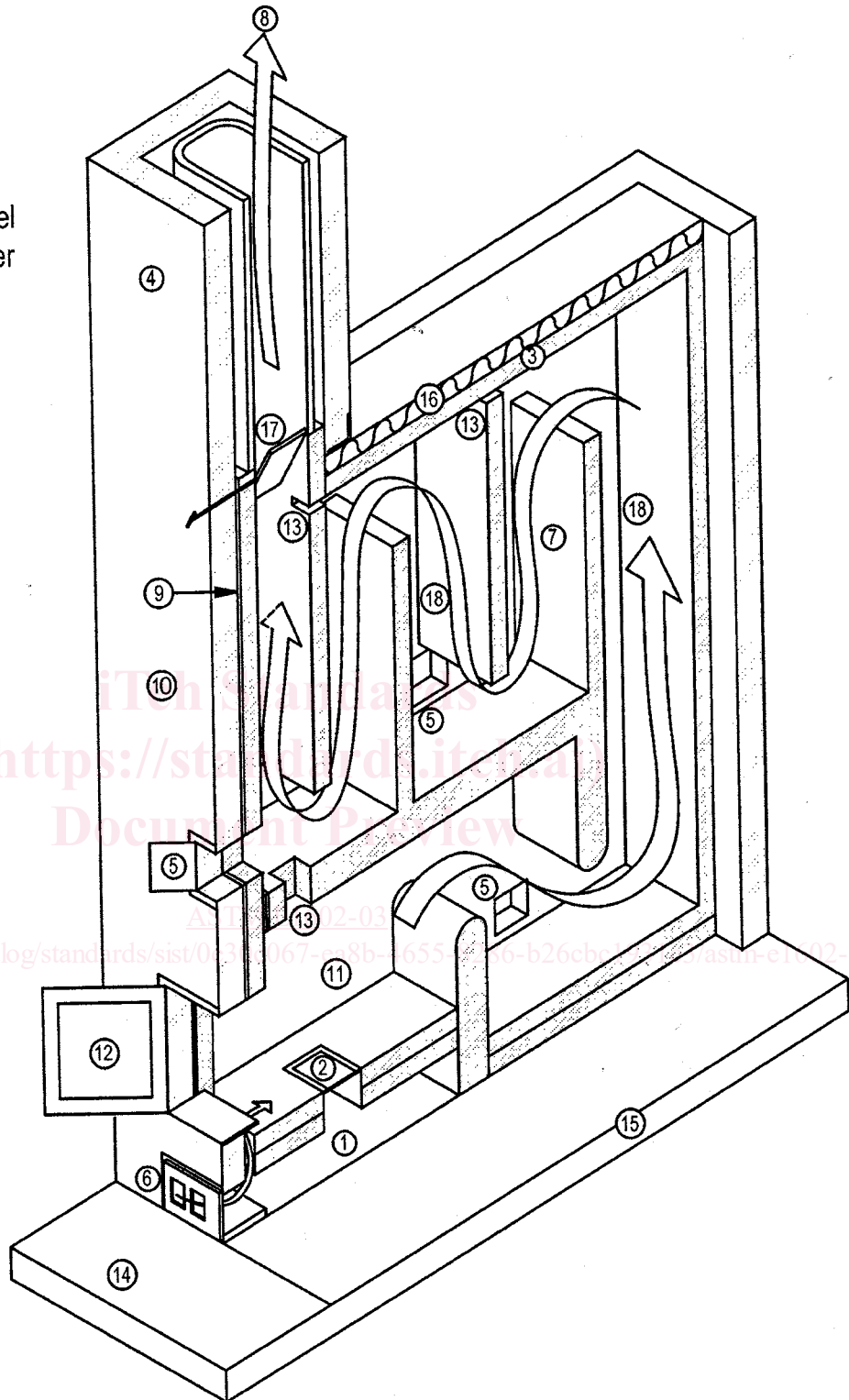
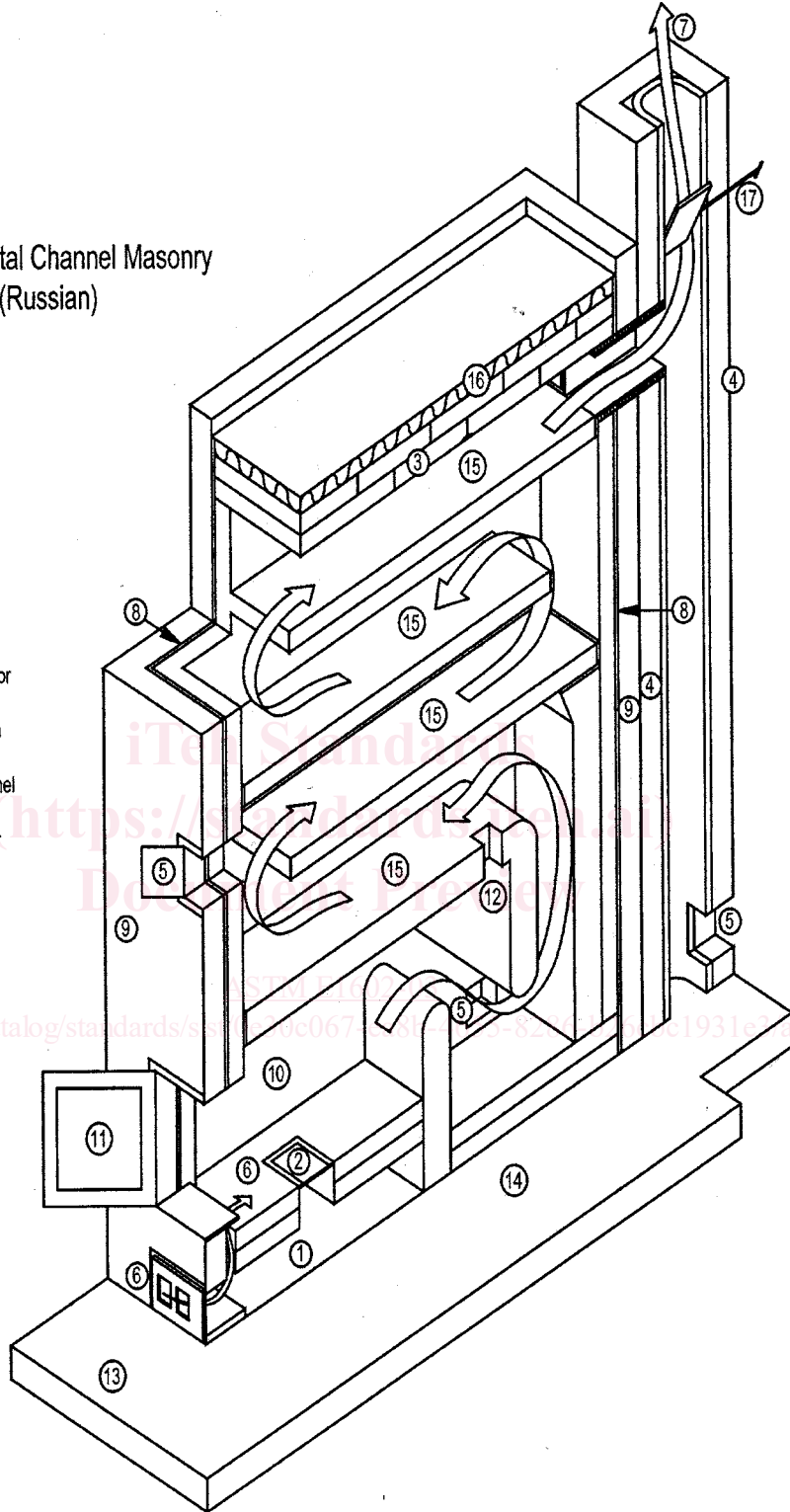

FIG. 2 Horizontal Channel Masonry Heater (Russian)

1. Ashbox
2. Ash Drop
3. Capping Slab
4. Chimney
5. Clean-Out
6. Combustion Air
7. Exhaust Gas
8. Expansion Joint
9. Exterior Wall
10. Firebox
11. Fuel-Loading Door
12. Gas Slot
13. Hearth Extension
14. Heater Base
15. Horizontal Channel
16. Insulation
17. Shut-Off Damper



<https://standards.iteh.ai/catalog/standards/sist/5e0674-8644-3-8220-1931e7atm-e1602-03>