**Textile-glass-reinforced plastics —
Determination of mechanical properties
on rods made of roving-reinforced
resin —**

Part 1:
**General considerations and preparation
of rods**

iTeh STANDARD PREVIEW
(standards.iteh.ai)

*Plastiques renforcés verre textile — Détermination des propriétés
mécaniques sur joncs de stratifiés —*

<https://standards.iteh.ai/catalog/standards/sist/b231b0c1-fad-4d6f-9759->

Partie 1: Notions générales et préparation des joncs



PDF disclaimer

This PDF file may contain embedded typefaces. In accordance with Adobe's licensing policy, this file may be printed or viewed but shall not be edited unless the typefaces which are embedded are licensed to and installed on the computer performing the editing. In downloading this file, parties accept therein the responsibility of not infringing Adobe's licensing policy. The ISO Central Secretariat accepts no liability in this area.

Adobe is a trademark of Adobe Systems Incorporated.

Details of the software products used to create this PDF file can be found in the General Info relative to the file; the PDF-creation parameters were optimized for printing. Every care has been taken to ensure that the file is suitable for use by ISO member bodies. In the unlikely event that a problem relating to it is found, please inform the Central Secretariat at the address given below.

iTeh STANDARD PREVIEW
(standards.iteh.ai)

[ISO 3597-1:2003](https://standards.iteh.ai/catalog/standards/sist/b231b0c1-fafd-4d6f-9759-0a5a4480f6d3/iso-3597-1-2003)

<https://standards.iteh.ai/catalog/standards/sist/b231b0c1-fafd-4d6f-9759-0a5a4480f6d3/iso-3597-1-2003>

© ISO 2003

All rights reserved. Unless otherwise specified, no part of this publication may be reproduced or utilized in any form or by any means, electronic or mechanical, including photocopying and microfilm, without permission in writing from either ISO at the address below or ISO's member body in the country of the requester.

ISO copyright office
Case postale 56 • CH-1211 Geneva 20
Tel. + 41 22 749 01 11
Fax + 41 22 749 09 47
E-mail copyright@iso.org
Web www.iso.org

Published in Switzerland

Contents

Page

Foreword	iv
1 Scope	1
2 Normative references	1
3 Principles	1
4 Conditioning and test atmospheres	2
5 Preparation of test specimens	2
Annex A (informative) Examples of resin systems and curing conditions	8
Bibliography	9

iTeh STANDARD PREVIEW
(standards.iteh.ai)

[ISO 3597-1:2003](https://standards.iteh.ai/catalog/standards/sist/b231b0c1-fafd-4d6f-9759-0a5a4480f6d3/iso-3597-1-2003)

<https://standards.iteh.ai/catalog/standards/sist/b231b0c1-fafd-4d6f-9759-0a5a4480f6d3/iso-3597-1-2003>

Foreword

ISO (the International Organization for Standardization) is a worldwide federation of national standards bodies (ISO member bodies). The work of preparing International Standards is normally carried out through ISO technical committees. Each member body interested in a subject for which a technical committee has been established has the right to be represented on that committee. International organizations, governmental and non-governmental, in liaison with ISO, also take part in the work. ISO collaborates closely with the International Electrotechnical Commission (IEC) on all matters of electrotechnical standardization.

International Standards are drafted in accordance with the rules given in the ISO/IEC Directives, Part 2.

The main task of technical committees is to prepare International Standards. Draft International Standards adopted by the technical committees are circulated to the member bodies for voting. Publication as an International Standard requires approval by at least 75 % of the member bodies casting a vote.

Attention is drawn to the possibility that some of the elements of this document may be the subject of patent rights. ISO shall not be held responsible for identifying any or all such patent rights.

ISO 3597-1 was prepared by Technical Committee ISO/TC 61, *Plastics*, Subcommittee SC 13, *Composites and reinforcement fibres*.

This second edition cancels and replaces the first edition (ISO 3597-1:1993), which has been technically revised.

ISO 3597 consists of the following parts, under the general title *Textile-glass-reinforced plastics — Determination of mechanical properties on rods made of roving-reinforced resin*:

- Part 1: *General considerations and preparation of rods*
- Part 2: *Determination of flexural strength*
- Part 3: *Determination of compressive strength*
- Part 4: *Determination of apparent interlaminar shear strength*

Textile-glass-reinforced plastics — Determination of mechanical properties on rods made of roving-reinforced resin —

Part 1: General considerations and preparation of rods

1 Scope

This part of ISO 3597 provides general information and specifies a method for preparing specimens (rods) intended to be used for tests specified in the other parts of ISO 3597.

2 Normative references

The following referenced documents are indispensable for the application of this document. For dated references, only the edition cited applies. For undated references, the latest edition of the referenced document (including any amendments) applies.

ISO 291, *Plastics — Standard atmospheres for conditioning and testing*
[https://standards.iteh.ai/catalog/standards/sist/6231b0c1-fafa-4d6f-9759-](https://standards.iteh.ai/catalog/standards/sist/6231b0c1-fafa-4d6f-9759-0a5a44805d3/iso-3597-1-2003)

ISO 1172, *Textile-glass-reinforced plastics — Prepregs, moulding compounds and laminates — Determination of the textile-glass and mineral-filler content — Calcination methods*

ISO 3597-2, *Textile-glass-reinforced plastics — Determination of mechanical properties on rods made of roving-reinforced resin — Part 2: Determination of flexural strength*

ISO 3597-3, *Textile-glass-reinforced plastics — Determination of mechanical properties on rods made of roving-reinforced resin — Part 3: Determination of compressive strength*

ISO 3597-4, *Textile-glass-reinforced plastics — Determination of mechanical properties on rods made of roving-reinforced resin — Part 4: Determination of apparent interlaminar shear strength*

3 Principles

3.1 General

The test methods specified in the other parts of ISO 3597 and briefly described hereafter are generally performed on “as-moulded” rods. They may, however, also be carried out on rods which have been subjected to treatment in boiling water for a specified length of time. It is also possible to carry out the tests after conditioning exposures other than boiling water. The medium used and the conditions of exposure shall be agreed upon between the interested parties.

The preparation of rods as detailed in Clause 5 includes the preparation and division of rods into specimens of given length and their treatment in boiling water, if such treatment is required.

In order to obtain consistent results, the conditions for the preparation of the rods (resin mixture composition, impregnation system and pulling speed, cure conditions, etc.) shall be as uniform as possible.

3.2 Determination of flexural strength

A specimen is laid horizontally on two supports and bent at constant speed by applying a force at midspan until the specimen breaks (see ISO 3597-2). This test is often referred to as a “three-point bending” test.

The flexural strength of the specimen, expressed in megapascals, is the calculated maximum bending stress in the rod at break.

3.3 Determination of compressive strength

A specimen is compressed longitudinally by applying forces at the specimen ends at a constant speed until the specimen breaks or until the deformation has reached a predetermined level (see ISO 3597-3).

The compressive strength of the specimen, expressed in megapascals, is the calculated compressive stress at the highest load applied.

3.4 Determination of apparent interlaminar shear strength

A flexural test is carried out as described in 3.2. However, the span used is significantly shorter in order to induce interlaminar shear failure as a result of the relatively high shear stresses in the midplane of the specimen (see ISO 3597-4).

The apparent interlaminar shear strength of the specimen, expressed in megapascals, is the calculated shear stress in the midplane of the specimen at the highest load applied.

iTeh STANDARD PREVIEW
(standardsiteh.ai)

4 Conditioning and test atmospheres

ISO 3597-1:2003

http://www.iso.org/standards/sist/b231b0c1-fafd-4d6f-9759-0a5a4480f6d3/iso-3597-1-2003

Use one of the atmospheres specified in ISO 291.

5 Preparation of test specimens

5.1 Apparatus and materials

5.1.1 Mould, in the form of a rigid hollow cylinder having a minimum length of 400 mm and an internal diameter of, preferably, 4 mm ± 0,3 mm or 6 mm ± 0,3 mm. If other diameters are chosen, these shall be selected by agreement between the interested parties in the range from 4 mm to 10 mm. However, the diameter used shall in all cases be reported, and only test data obtained with moulds of the same diameter shall be used for comparative purposes.

The mould may be constructed of glass or polytetrafluoroethylene (PTFE). A release agent may be used in the mould if the shrinkage of the moulding is very low (typical of epoxy resins). However, an internal release agent (a release agent that is mixed into the resin) will affect the test results. Adding a release agent is not recommended. When using a release agent, it shall be mentioned in the test report.

5.1.2 Resin, suitable for use with the reinforcement to be tested (the manufacturer of the reinforcement roving normally gives general recommendations). The resin system selected shall be prepared before use in accordance with the resin manufacturer's detailed instructions (see Annex A for examples of resin formulae and curing conditions).

5.1.3 Metal wire or yarn, for pulling impregnated rovings into the mould.

5.1.4 Impregnation equipment (see Figure 1), comprising a long, shallow impregnation bath to impregnate a hank of rovings with resin. It is recommended that the bath be made of metal to facilitate heating of the resin to lower its viscosity if required. This is common practice for those resins, such as epoxy, whose room temperature viscosity may be too high to adequately impregnate the hanks of roving.

It is recommended that the rovings be pre-soaked in the bath of resin to facilitate wet-out and air removal. When a large number of rods are to be made, having two or more baths and switching the pulling of hanks from one bath to another while rovings soak in the other baths has been found an effective technique.

Lining the impregnation bath with thin cellophane foil keeps the bath from becoming coated with resin and makes cleaning faster with less need for cleaning solvents. The mould support shall be fitted with a device to prevent the mould moving as rovings are pulled into it. The rovings are pulled into the mould by means of a metal wire or yarn attached to the hank of roving. The wire or yarn can be pulled by a winding device. The winder can be hand cranked or motor-driven. Care shall be taken that the hanks of roving are pulled into the mould at a slow enough speed for the minimum amount of air to be trapped in the rovings.

NOTE When using low-shrinkage resin, a hand crank and chain may be used to remove the cured rod from the mould. Also, glass tubes that can be broken after curing may be used as the mould.

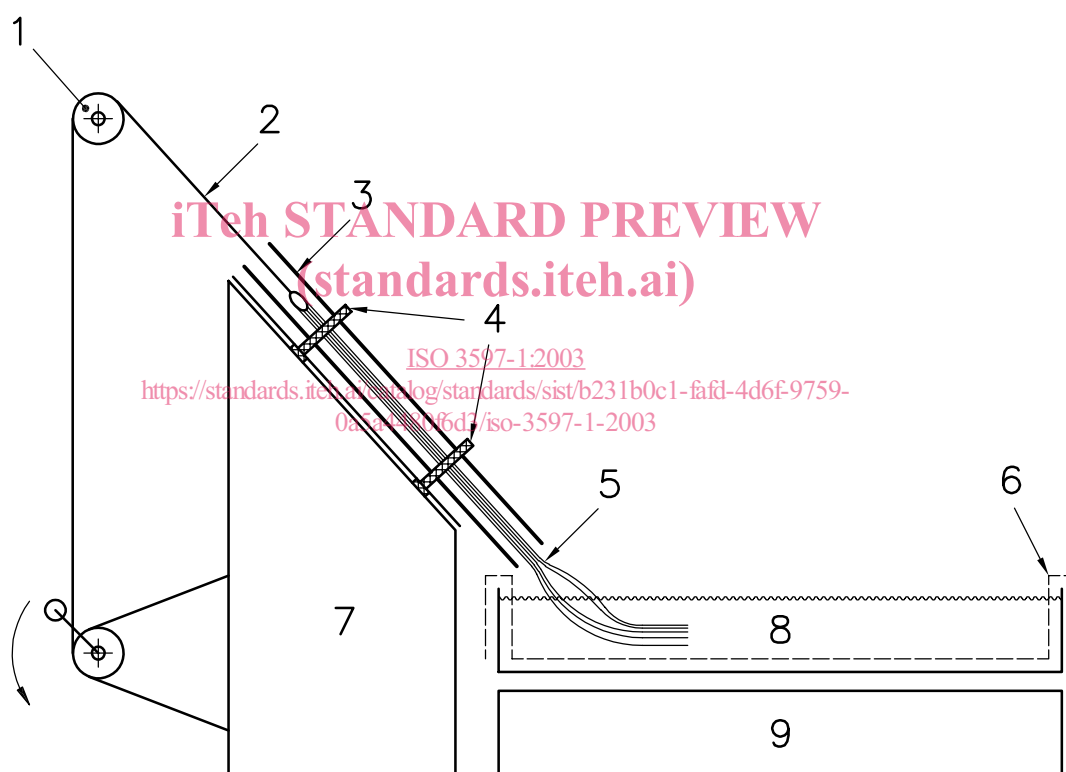

Key

- | | |
|-------------------------------|---------------------------|
| 1 guide roll | 6 cellophane foil |
| 2 wire or yarn | 7 mould support |
| 3 mould | 8 resin bath |
| 4 clamping device | 9 heating unit (optional) |
| 5 impregnated hank of rovings | |

Figure 1 — Example of equipment set-up for impregnation of rovings

- 5.1.5 **Circulating-air oven**, for curing and/or post-curing the resin at the recommended temperature.
- 5.1.6 **Diamond-tipped saw**, for cutting the cured rods to specimens of the required length.
- 5.1.7 **Heating device** and **suitable glassware**, if boiling-water pretreatment of the test specimens is required.
- 5.1.8 **Former** (see Figure 2), with a circumference of 1 m, for winding a hank of rovings.

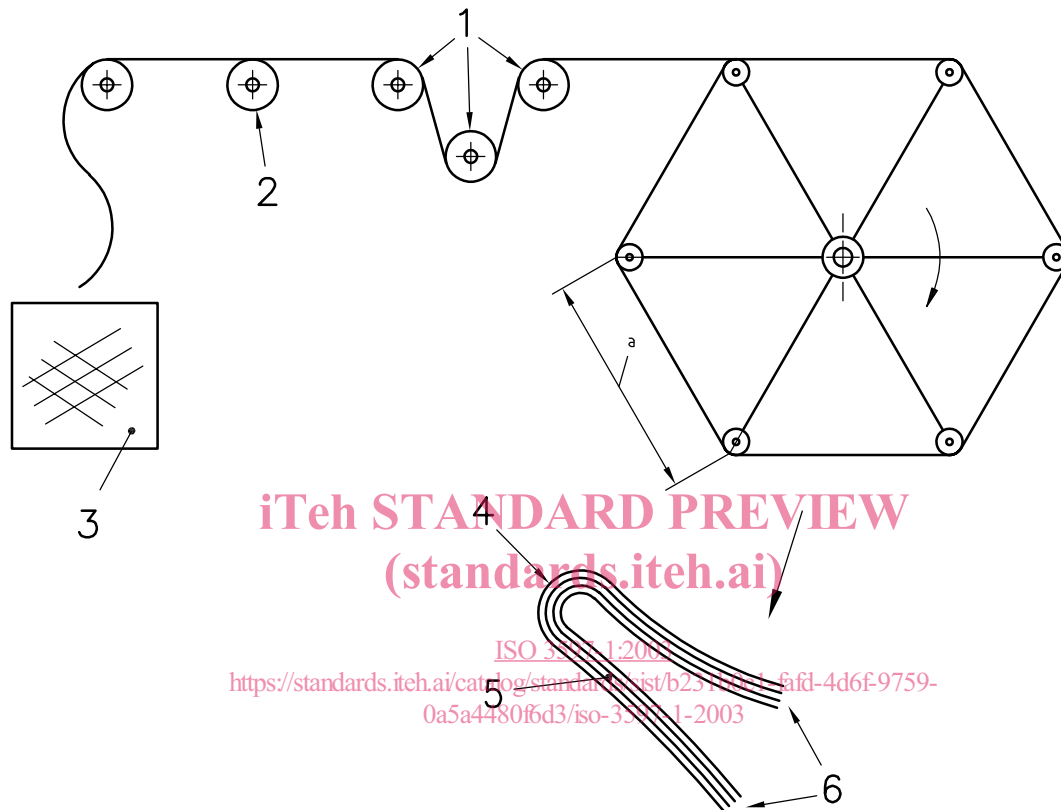

- Key**
- | | |
|------------------------|-------------------------------------|
| 1 tensioning rolls | 4 attachment point for wire or yarn |
| 2 loop roll (optional) | 5 hank of rovings |
| 3 roving bobbin | 6 cut ends |
- ^a Each side 1/6 m.

Figure 2 — Winding a hank of rovings

5.2 Preparation of hanks of rovings

First, using Equation (1), calculate the mass of roving needed to give a glass content of $(65 \pm 1) \%$ by mass in the specimens produced. Then use Equation (2) to calculate the number of turns N of roving which will have to be wound on the former to give this mass. To calculate N , it is necessary to know the mass per unit length of the rovings. This is usually stated by the manufacturer (the tex value, in $\text{g}\cdot\text{km}^{-1}$).

NOTE The mass per unit length can be determined using ISO 1889^[1].

Because it will generally only be possible to wind complete metre lengths on to the former, round up to the nearest whole number.

$$m = \frac{w_f}{\left(\frac{w_f}{\rho_f}\right) + \left(\frac{w_r}{\rho_r}\right)} \times \frac{\pi d^2}{4} \times l \quad (1)$$

$$N = \frac{m}{\text{tex}} \times 1000 \quad (2)$$

where

m is the mass, in grams, of the hank of rovings;

w_f is the glass content, in percent by mass;

ρ_f is the density, in grams per cubic centimetre, of the glass;

w_r is the resin content, in percent by mass (without voids, $w_r = 100 - w_f$);

ρ_r is the density, in grams per cubic centimetre, of the resin;

d is the inside diameter, in millimetres, of the mould;

l is the length of the hank drawn into the mould;

tex is the mass per unit length, in grams per kilometre, of the roving.

Wind a roving N times around the former. When the calculated number of turns has been collected, remove the roving from the wheel by cutting it on one side of the former. The bundle of roving fibres obtained will be 1,0 m long. Form a hank by folding the bundle at the midpoint (see Figure 2). The length of the hank will be 0,5 m. Cut the hank to length if a mould shorter than this is being used. Check the mass of the hank. In some cases, it may be necessary to reduce the mass of the hank by removing fibres from it. Attach a pulling wire or yarn to the loop end at the point shown in Figure 2. The wire or yarn keeps the fibres together and shall be of sufficient length to pull the hank from the resin bath into the mould. Take care to minimize handling of the roving to avoid contamination. When the roving bobbin and/or resin are stored in a conditioned room, it is not necessary to condition them before use. If not, condition for at least 16 h in one of the standard atmospheres specified in ISO 291.

5.3 Preparation of rods

Prepare an amount of resin sufficient to prepare the required number of rods. Use the resin either at ambient temperature in a conditioned room or at an elevated temperature if it is necessary to lower the resin viscosity. The elevated temperature can be specified by the manufacturer or be determined by preliminary trials. When the rovings have been conditioned, pour the resin into the impregnating bath(s).

Impregnate the roving by immersion in a bath containing the resin. In order to facilitate immersion and to enable air bubbles to escape, push the rovings gently (avoiding damage) to the bottom of the bath with a plastic spoon or wooden stirrer. The wire or yarn connected to the hank shall be kept out of the bath.

Because deficiencies in impregnation may cause considerable scatter in test results, care is necessary in this operation. The hank of rovings shall be completely impregnated before it is pulled into the mould. Good-quality impregnation is characterized by the absence of trapped air bubbles and usually the apparent disappearance of the fibres in the resin as wet-out occurs. The impregnation time shall be at least 10 min in all cases. With rovings that are hard to impregnate, use longer times and push the rovings around the bath with the stirrer or spoon to allow the air to escape. A bar near the entrance to the mould may be used to assist in removing air.